

Islamic Republic of Iran
Vice Presidency for Strategic Planning and Supervision

Guideline for seismic evaluation and rehabilitation of water supply systems

No. 609

Office of Deputy for Strategic Supervision
Department of Technical Affairs



omoorepeyman.ir

Table of Content	Page Number
Chapter 1- General	
1-General	3
1-1- Objectives	3
1-2-Scope.....	3
1-3-Objective Components.....	3
1-4-Relevant Provisions	4
1-5-Guideline Structure	5
Chapter 2- Seismic Assessment Procedure	
2-Seismic Assessment Procedure	9
2-1-Seismic Assessment Approach	9
2-2-Pre-Assessment.....	10
2-2-1-Various Assessment Requests	11
2-2-2-Effective Factors in Performance Assessment	11
2-2-3-Identify Seismic Hazards.....	12
2-2-4-Identify Seismic Vulnerability.....	12
2-2-5-Seismic Performance	13
2-2-6-Planning for Assessment Studies.....	15
2-3-Seismic Assessment Steps	20
2-3-1-Identify Component/System Importance.....	20
2-3-2-Earthquake Hazard Levels.....	21
2-3-3-Performance Level of System Components	22
Chapter 3- Seismic Assessment Methods	
3-Seismic Assessment Methods	25
3-1-Objective Components.....	25
3-2-General Approach of Vulnerability Determination	25
3-3-Seismic Assessment Methods of Components.....	27
3-3-1-Seismic Assessment of Buildings.....	27
3-3-2-Seismic Assessment of Non-Building Structures	28
3-3-3-Seismic Assessment of Equipment.....	28
3-3-4-Seismic Assessment of Non-Structural Elements.....	29
3-3-5-Seismic Assessment of Network and Pipeline.....	29
3-4-Inspection in Qualitative Assessment	29
3-5-Gathering Required Information in Detailed Assessment	31
3-5-1-Gathering Design and Operation Documents	32
3-5-2-Objective Inspection and Derivation of Obvious and Effective Difficulties	32
3-5-3-Material and Soil Experiments and Hazard Analysis Studies	32
3-6-Seismic Assessment by Structure Modeling and Numerical Analysis	33
3-6-1-Equal Static Method	33
3-6-2-Spectrum Method	33
3-6-3-Time History Method	33
3-7-Considering Seismic Interaction Effect of Systems.....	34
3-8-Acceptability Criteria.....	34

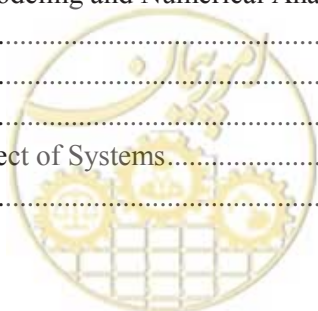

3-8-1-Imposed Forces Combinations	34
3-8-2-Stability Controls.....	34
3-8-3-Acceptability Criteria in Nonlinear Dynamic Methods.....	34
Chapter 4-Seismic Retrofitting Procedure	
4-Seismic Retrofitting Procedure	37
4-1-Retrofitting Prioritizing	37
4-2-Seismic Retrofitting Procedure.....	37
Chapter 5- Rehabilitation Methods	
5-1- Rehabilitation Method Selection Approach.....	41
5-2- Failure Modes and Type of Rehabilitation Method.....	41
5-2-1- Reservoirs.....	41
5-2-2- Treatment Plant and Pump Station.....	44
5-2-3- Transfer and distribution Pipeline	44
5-2-3-1- Failure Modes	44
5-2-3-2- Rehabilitation Methods.....	47
5-2-3-2-1- Seismic Rehabilitation of Fault Crossing Pipelines.....	48
5-2-3-2-2- Buried Pipeline Rehabilitation for the Other Failure Modes.....	50
5-2-3-3- Manhole, Concrete Conduit, Shield Tunnel and Access Routes.....	67
5-2-3-3-1- Seismic Failure Modes	67
5-2-3-3-2- Retrofitting Manhole for Every Failure Mode.....	68
5-2-3-3-Pipe Joining Equipment	83
5-2-3-3-1-Failure Modes	83
5-2-3-3-2-Rehabilitation.....	84
5-2-4- Other Non-Building Structures	89
5-2-4-1- Main Components.....	89
5-2-4-2-Water Duct.....	90
5-2-4-2-1-Seismic Failures.....	90
5-2-4-2-2-Assessment	91
5-2-4-2-3-Retrofitting.....	92
5-2-4-3-5-Dike	93
5-2-4-3-5-1-Assessment.....	93
5-2-4-3-5-2-Retrofitting	94
5-2-4-4-Buildings	94



Chapter 1

General



1-General

Water systems have a vital role to protect life and respond to the important needs such as drinking, health and nourishment. Earthquake is one of the natural hazards that can damage the systems and cause water outage and occur to secondary events like flooding, storm surge, building collapse and settlement.

Lack of information about vulnerability rate to provide required resistance and safety and not enough seismic Retrofitting, can cause an increase in outcomes and damages due to earthquake. Inability to appropriate control of emergency situation may yield to disaster and critical conditions.

1-1- Objectives

The purpose of municipal water system vulnerability assessment and seismic Retrofitting is to be informed of seismic vulnerability safety and then decrease outcomes due to earthquake impacts on this system and its components.

To maintain integration and continuity of safe performance of municipal water system via this will ensure lack of hazardous and unacceptable risk to the people's life, their properties, and environment.

Vulnerability assessment and seismic Retrofitting contain all actions of lacks recognition and probable damages and their outcomes and include mitigation, elimination, and curing partially reasonable measures when earthquake occurs with significant or unacceptable risk. So, main objectives of providing this guideline are:

- Definition and determination of general requirements of seismic vulnerability assessment of existing water system to be used uniform and coordinate throughout the country.
- Recommend solutions to seismic Retrofitting of water system and mitigation management and their probable critical and emergency situation.

1-2-Scope

This guideline can be used for all of the water lifeline components in storage, transmission, treatment and municipal distribution in various capacities and sizes.

The contents provide a background to improve engineering knowledge level in seismic safety, but the user has the responsibility of correct interpretation and using this guideline. Contents of the guideline will revise in time and users should use the last updated version.

Safety assessment against other natural and unnatural factors and relevant considerations is not in the framework of this guideline and should revise complementary when needed. Requirements of the guideline for the permanent and temporary facilities are the same.

1-3-Objective Components

Objective components in this guideline are divided into two basic portions:

- Stationed components such as buildings, non-building structures, equipment and nonstructural elements in tanks, wells, pump stations and pressure adjusting and treatment plants.
- Linear (tunnels and pipelines) and network (water distribution) components

Stationed components except in few cases are mainly above ground. While pipelines and network structures are mainly buried under ground and in some cases above ground. Stationed structures are principally affected by ground acceleration response to earthquake, while linear and network structures

that are mainly buried are affected more from ground velocity response. Stationed equipment is organized in two different types; inside or outside of the building.

Lifeline stationed structures contrary to buildings that their mass is distributed regularly in stories and height have not a distinguished distribution of mass, So inertial force from earthquake on them is affected on their mass center. This force is calculated by multiplying the structure mass by modified acceleration in the form of earthquake coefficient. In some storage structures such as tanks inertial force due to effecting of earthquake on the containing mass will be considered and distributed statically or dynamically in relevant place according to the type of the analysis method and its mathematical model. The case of some few partially buried structures appropriate loading will be done according to the analysis method and its mathematical method (free parts, clamping or semi- clamping).

Long linear and network structures either underground or above ground are sensitive to the imposed relative displacement.

Imposed relative displacement converts to strain and stress in these structures. Effect of inertia in linear and network structures will decrease more from above ground to buried one, because in buried structures the behavior is practically affected by soil behavior and in comparison with local soil the mass is negligible and ignorant.

Water system components considered in this guideline are given in table 1.1.

Table 1.1 Objective Components in This Guideline

Type	Title
Stationed	Water storage facility such as above ground, buried and under pressure tanks
Stationed	Adjusting pressure facilities such as pumping stations, oil-water pumping stations, underground water wells, pressure tanks, balance tanks, and diversion structures.
Linear	Pipelines, canals and main underground and aboveground high pressure transfer tunnel
Stationed	Treatment plants
Linear	Distribution pipelines
Stationed	Service and fire hydrant connections
Stationed	Administrative and public buildings and supporting buildings
Stationed	Customer`s branches

1-4-Relevant Provisions

Relevant codes and instruction of this guideline are:

- Building Design Codes for Earthquakes – Iran Standard 2800- 3d version, Ministry of housing and urban development.
- Instruction for Seismic Retrofitting of Existing Buildings, No.360, President Deputy Strategic Planning and Control.
- Rapid Seismic Evaluation of Existing Buildings, No. 364, President Deputy Strategic Planning and Control.
- Term of Reference for Seismic Retrofitting of Existing Buildings, No.251, President Deputy Strategic Planning and Control.
- Instruction for Seismic Retrofitting of Existing Unreinforced Masonry Buildings, No.376, President Deputy Strategic Planning and Control.
- IRAN National Building Provisions, Ministry of Housing and Urban Planning.



Using other guidelines or criteria that may be necessary in specific projects, if there is general accordance with concepts of this guideline and meet minimal criteria, is allowed.

1-5-Guideline Structure

This guideline includes chapters and indexes as followings:

Chapter 1: General

Chapter 2: Seismic Assessment Procedure

Chapter 3: Seismic Assessment Methods

Chapter 4: Seismic Retrofitting Procedure

Chapter 5: Seismic Retrofitting Methods

Index 1: Water Distribution Customers Categorization

Index 2: Vulnerability Curves

In chapter 2 general procedures for seismic assessment of water system is given. The procedure defines seismic assessment studies in two general section, pre-assessment and assessment. Pre-assessment will be discussed in this chapter and assessment methods will be introduced in the next chapter.

Seismic pre-assessment method in this chapter is given to forecast general seismic vulnerability of the components and by using it, primary screening of vulnerable components will be done. Also, considering all assessment requests according to employer purpose can identify general level of studies and types of outputs.

To perform pre-assessment, effective factors in performance assessment is introduced in this chapter and based on it, assessment level index is determined and assessment level will be selected.

Based on selected level, recommended sections for planning of assessment studies and also steps of continuing studies after finishing pre-assessment to provide required Term of Reference for assessment, is given in the continuance of this chapter.

In chapter 3 after introducing objective components in water system, vulnerability assessment methods in 3 categories rapid, qualitative and detailed for different assessment level specified in chapter 2, is recommended as a matrix for different components. For every method and components in addition to describing important factors in assessment, relevant regulations for determining details of methods are listed.

About rapid and qualitative assessment, considering importance of technical inspection in these two methods, important notes in order to consider in providing or completing useful worksheets in this section is given in chapter 3.

Details of detailed methods for different components like loading combinations and seismic capacity calculation and acceptance criteria further to what has stated in chapter 3, is dependent on details of seismic design methods of each component and to determine them can refer to relevant regulations introduced in this chapter for each component.

In chapters 4, 5 respectively procedures and methods of rehabilitation are discussed. Rehabilitation procedures include defining effective factors in prioritizing and steps of providing rehabilitation plan. A different rehabilitation method for different components, individually and with required primary details, is the subject of chapter 5 in this guideline.



Chapter 2

Seismic Assessment Procedure



2-Seismic Assessment Procedure

2-1-Seismic Assessment Approach

Seismic Assessment in this guideline describes in two phases. First phase is pre-assessment with rapid investigation of lifeline conditions, in addition to determining the need or no need to seismic evaluation. It will be determined evaluation level of study. Then in assessment phase activities describe as two parts; preliminary and detailed assessment.

- Preliminary assessment includes qualitative and empirical methods and relatively rapid to determine specific vulnerable or safe elements and provide a list of elements that require detailed assessment. Preliminary assessment methods in this guideline are mainly on basis of using preliminary assessment worksheet with qualitative or quantitative scoring.
- Detailed assessment includes two empirical and analytical approaches. Empirical methods were based on failure modes and damage statistics and records in the past earthquakes and analytical methods were based on modeling and calculative and numerical analysis. Empirical methods are used often for seismic assessment of networks with many components. The empirical methods are based on empirical and probabilistic failure curves of different components in different modes. More explanation about failure curves is given in index 1. Analytical methods have also two levels. First level is similar to simplified design methods and mainly is equivalent static. Second level is used for components in specific condition or complicated seismic behavior and includes dynamic and nonlinear methods.

Roadmap of performance assessment is shown in the figure below.



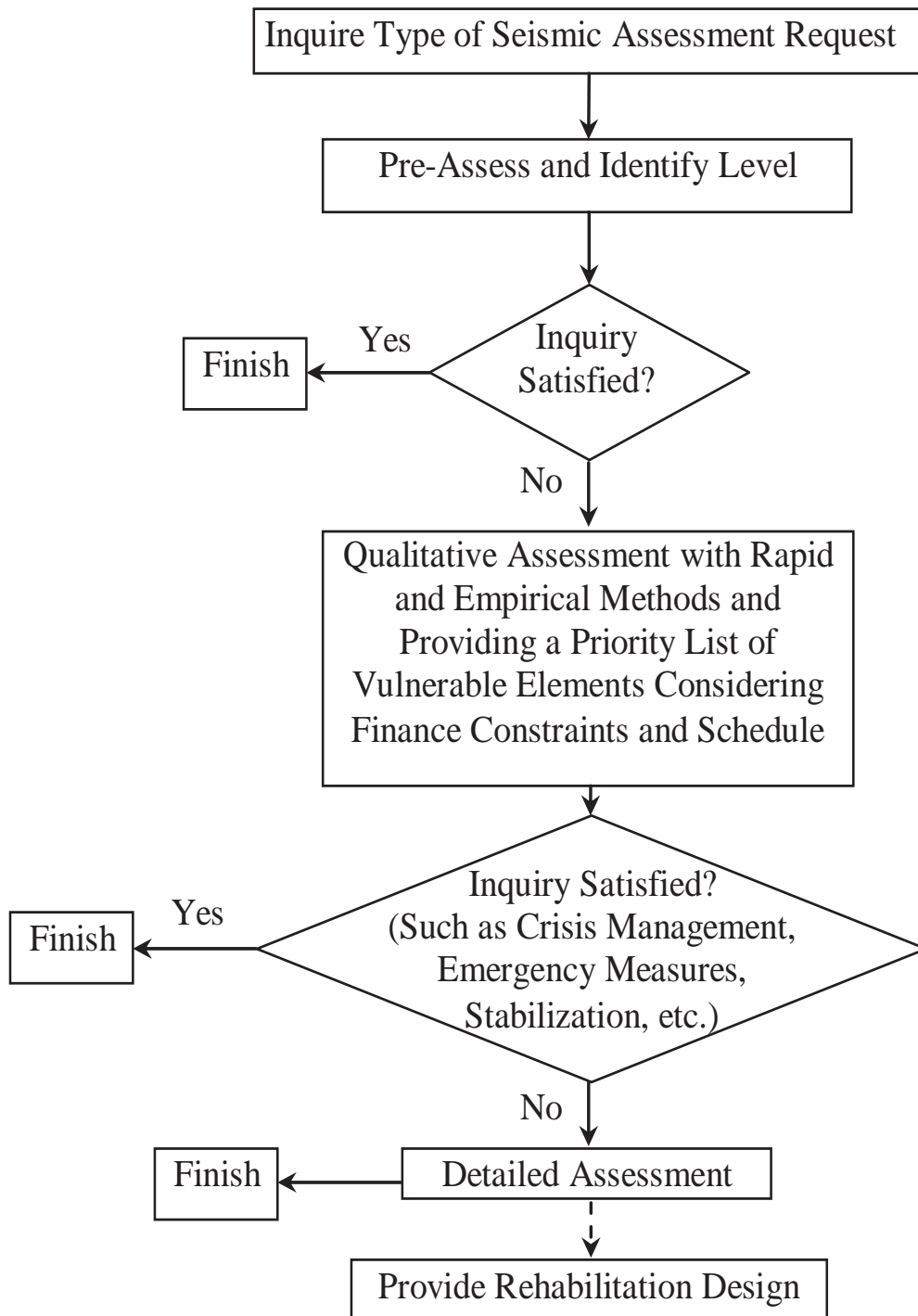
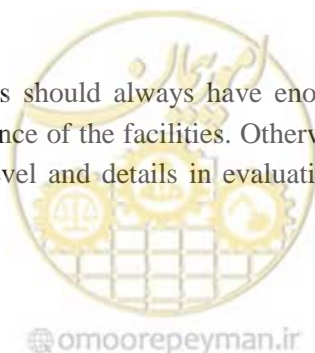

Figure 2.1 Roadmap of Performance Assessment

2-2-Pre-Assessment

Water lifeline operator or authorities should always have enough information and assurance about safety and appropriate seismic performance of the facilities. Otherwise, performance assessment of water facilities will be requested. Required level and details in evaluation is dependent on requester level of



needed information. Before starting assessment phase of pre-assessment phase is performed with following objectives that can be done by operator engineers or authorities.

- Identification the hazard severity and assess the general vulnerability of the system by the hazard to determine the need for a more detailed assessment.
- Ensure that adequate resources and expertise are available to perform the evaluation.
- Determine the appropriate level of analysis based on the inquiry and available resources and schedule.

2-2-1-Variou s Assessment Requests

Assessment request may have one of these three following approaches:

- Technical approach (mainly with the target of safety promotion with rehabilitation actions)
- Financial approach (mainly with the target of budget planning or damage estimation, recovery and investment risk)
- Management approach (mainly with the targets such as crisis management planning, emergency measures planning, increasing safety planning by software or non-rehabilitation methods and risk management)

Components that should be considered in the evaluation are dependent on request and target performance. So, authorities should decide on which component should be assessed. Reliability in this scenario will be measured by duration of being out of service and water outage.

This may not requested for the entire network and be based on emergency management priorities. In this case the calculation of certainty of services will be started with the customers of higher priority that have an important role in control and emergency management. Providing the list and selection method of important customers in a system will be done by guidance in index 1.

2-2-2-Effective Factors in Performance Assessment

Main factors of a performance assessment are:

- Hazard (H):
Seismic hazard include primarily and secondary hazards.
Primary hazard include vibration and strong ground motion and deformation due to it such as liquefaction, slope sliding and faulting.
Secondary hazards such as flooding, storm surge, building collapse and settlement, environmental pollution and so on, will occur due to earthquake primary losses.
- Vulnerability □□□
Vulnerability consists of potential for fatalities and physical losses relevant to equipment and facilities and buildings, operational and control systems, environment, industrial, administrative, financial, commercial activities, security of utility and investment and community and cultural heritage.
- System performance (S)
Water lifeline performance in earthquake hazard will be evaluated and judged by outputs or functional targets and/or safety failing and functional disturbance. The most important functional targets of water system are:
1-Protect public and utility personnel safety
2-Continuous water flow and maintain system reliability

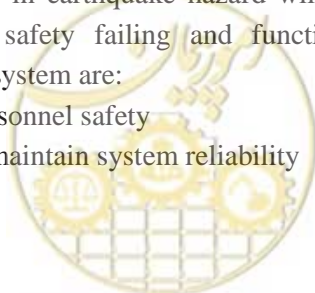

3-Prevent monetary losses

4-Prevent environmental damages.

2-2-3-Identify Seismic Hazards

Primary seismic hazards such as vibrations and permanent ground deformation will be evaluated by intensity, acceleration and strong ground motions.

The most common criteria for evaluation of vibration is peak acceleration (PGA), derived from seismic hazard zone maps or local studies.

To investigate hazards of permanent deformation such as liquefaction, slope sliding and faulting that mainly are based on peak ground displacement (PGD), also can use the hazard zoning maps. Information of the maps is approximate and to some extent conservative. For instance, a province may be in high risk category against landslide, just because a little portion of it is located on unstable slopes.

Secondary seismic hazards such as flooding, storm surge, building collapse and ground settlement, environmental pollution and so on, should be investigated locally and by the case.

Table 2.1 Criteria Used for Determining Relative Hazard Level (H)

Seismic Hazard Level	Limits of Peak Ground Acceleration
Low (L)	PGA < 0.15 g
Medium (M)	$0.15g \leq PGA \leq 0.5 g$
High (H)	PGA > 0.5g

4-2-2-Identify Seismic Vulnerability

Considering the past earthquakes, potential damage in different parts of water utilities is different from the other seismic hazards.

In table 2.2 general classification of it has been shown in 3 classes of high (H), medium (M) and low (L). If an element or system is located in a building, vulnerability of the building and that element should be considered together. For example, where there is a probability of building collapse or compulsory evacuation equipment inside it is exposed to hazard.

Table 2.2 Vulnerability Levels of Components in Earthquake Damages

Hazard	Components												
	Wells	Canals	Tunnels	Transmission Pipelines	Distribution Pipelines	Supporting Service	Above ground Storage Tanks	Buried Storage Tanks	Treatment Plant Facilities	Diversion Structures	Pump Station	Computer and Electrical Equipment	Administrative and Supporting and Operational Buildings
Earthquake Vibration	L	L	L	-	L	L	H	M	M	M	M	M	M
Permanent Ground Deformation due to	H	H	H	H	H	H	H	H	H	H	H	-	H

Earthquake (Faulting, Liquefaction, Landslide, Settlement)														
--	--	--	--	--	--	--	--	--	--	--	--	--	--	--

2-2-5-Seismic Performance

Seismic performance depends on these factors:

- Intensity and rate of hazard
- Vulnerability of system or component
- Consequences from damage such as fatalities, financial, service outage, environmental and other impacts.
- Permanent redundancy of evaluated system (high redundancy, medium redundancy, or no redundancy)
- Scale of System

Operational criteria importance rating (OCR) is used to evaluate the system performance. Calculating total rating is according to the equation 2.1. Note: when compare the total ratings together, they should be related to one type of hazard.

$$R = H \times V \times OCR \quad (2.1)$$

Where:

H: the rating score related to hazard (low=1, medium=2, high=3, according to table 2.1)

V: the rating score related to vulnerability (low=1, medium=2, high=3, according to table 2.2)

OCR: operational criteria importance rating

OCR is a combination of system importance rating (SR) and user importance rating (UR) and also relative coefficients.

$$OCR = f_s SR + f_u UR \quad (2.2)$$

Where:

SR: System importance rating (integer from 1 to 5)

UR: User importance rating (integer from 1 to 5)

f_s : System operation relative coefficient (from 0 to 1)

f_u : User Relative coefficient (from 0 to 1)

$$f_s + f_u = 1 \quad (2.3)$$

System importance rating (SR) will be selected in range 1 (for system operation with low importance) to 5 (for system operation with high importance). For instance, for tanks SR can be determined by their capacity ranges.

- 5: More than 10000 cubic meters
- 4: Between 7000 to 10000 cubic meters
- 3: Between 5000 to 7000 cubic meters



- 2: Between 3000 to 5000 cubic meters
- 1: Less than 3000 cubic meters

Also, for pump stations SR can be determined by their capacities.

- 5: More than 600 liter per sec
- 4: Between 300 to 600 liter per sec
- 3: Between 150 to 300 liter per sec
- 2: Between 60 to 150 liter per sec
- 1: Less than 60 liter per sec

Respectively, for the other equipment of water system considering existing water content SR can be determined.

User importance rating (UR) is combination of three following ratings.

- PR: Potable water supply importance rating (integer from 1 to 5)
- FR: Fire flow supply importance rating (integer from 1 to 5)
- LR: Life safety importance rating (integer from 1 to 5)

Summing the top ratings with applying relative importance coefficient gives user importance rating value.

$$UR = f_p PR + f_f FR + f_l LR \quad (2.4)$$

Where:

f_p : Potable water relative importance coefficient (from 0 to 1)

f_f : Fire flow relative importance coefficient (from 0 to 1)

f_l : Life safety relative importance coefficient (from 0 to 1)

$$f_p + f_f + f_l = 1 \quad (2.5)$$

There are examples of determining rating values of PR, FR and LR:

- Potable Water Supply Rating (PR)

- 5: system can supply more than 80% potable water.
- 4: System can supply less than 80% entire potable water.
- 3: System can supply less than 50% entire potable water.
- 2: System can supply less than 20% entire potable water.
- 1: System can supply less than 5% entire potable water.

- Fire Flow Supply Rating (FR)

- 5: 100% fire hydrant service is needed.
- 4: 70% fire hydrant service is needed.
- 3: 30% fire hydrant service is needed.
- 2: 10% fire hydrant service is needed.
- 1: system has no need to fire hydrant service.

- Life Safety Rating (LR)

- 5: Hazardous factors are enough to cause main problems outside the location.
- 4: Hazardous factors are not enough to cause main problems outside the location.

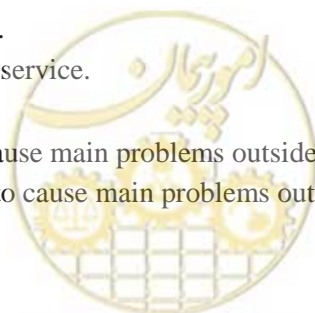

3: More than 75% presence time of personnel in system location.

2: Less than 75% presence time of personnel in system location.

1: Less than 20% presence time of personnel in system location.

At the end, considering total rating value (R) can identify a base level for performance assessment according to the table 2.3.

Table 2.3 Assessment Level Selection

Rating Level (R)	Base Level to Performance Assessment
$R \leq 6$	Seismic assessment is not necessary
$7 \leq R < 17$	Preliminary assessment is generally sufficient (Level 1)
$17 \leq R < 35$	Preliminary and detailed assessment by common empirical and calculative methods (Level 2)
$R \geq 35$	Preliminary and detailed assessment by accurate calculative methods (Level 3)

2-2-6-Planning for Assessment Studies

Required information for seismic assessment and nature of studies are different based on various seismic levels. Further to the table guides in this section there are cases like cost and schedule and also regarding numerous hazards that should be considered in planning nature of seismic assessment level.

Table 2.4 Hazard Assessment Matrix for Water System

Hazard/ Measure		H1	H2	H3
1.1	Earthquake Hazard-Surface Fault Rupture			
1.1.1	Review active fault hazard mapping for area, if available	♦	♦	♦
1.1.2	Review topographic maps	♦	♦	♦
1.1.3	Review stereo aerial photographs, if available		♦	♦
1.1.4	Perform field reconnaissance (by qualified geologist)		♦	♦
1.1.5	Conduct site specific fault investigation by trench excavation			♦
1.1.6	Estimate fault displacement using empirical methods		♦	♦
1.1.7	Identify fault displacements and occurrences by soil borings, sampling, age assign and analyses			♦



Hazard/ Measure		H1	H2	H3
1.2	Earthquake Hazard-Liquefaction			
1.2.1	Review literature on regional vibrations (seismicity)	♦	♦	♦
1.2.2	Perform PSHA (probabilistic seismic hazard evaluation) in the entire system		♦	♦
1.2.3	Review topographic maps	♦	♦	♦
1.2.4	Review surface geologic maps	♦	♦	♦
1.2.5	Review relevant geotechnical data	♦	♦	♦
1.2.6	Conduct minimal soil boring, SPTs (standard penetration test), and/or CPTs (cone penetration test)		♦	
1.2.7	Conduct extended soil boring, SPTs (standard penetration test), and/or CPTs (cone penetration test)			♦
1.2.8	Perform intermediate field reconnaissance (by qualified geotechnical engineer)		♦	♦
1.2.9	Identify potentially liquefiable soil deposits by judgment	♦	♦	♦
1.2.10	Identify potentially liquefiable soil deposits by engineering analysis of soil data		♦	♦
1.2.11	Estimate lateral spread displacements using empirical methods		♦	♦
1.2.12	Estimate liquefaction potential using liquefaction susceptibility maps		♦	♦
1.2.13	Perform detailed analysis using analytical tools, Estimate liquefaction susceptibility and lateral spread displacements			♦

Hazard/ Measure		H1	H2	H3
1.3	Earthquake Hazard- Strong ground shaking			
1.3.1	Review literature on regional seismicity	♦	♦	♦
1.3.2	Review seismic hazard mapping for area, if available	♦	♦	♦
1.3.3	Review surface geologic maps	♦	♦	♦
1.3.4	Identify and develop ground motion amplification factors		♦	♦
1.3.5	Estimate ground motion levels using judgment and existing maps	♦	♦	♦
1.3.6	Estimate ground motion levels using empirical methods		♦	♦
1.3.7	Estimate ground motion levels using analytical tools			♦
1.3.8	Perform PSHA (probabilistic seismic hazard evaluation) in the entire system			♦

Hazard/ Measure		H1	H2	H3
1.4	Earthquake Hazard- Landslide			
1.4.1	Review surface geologic maps	♦	♦	♦
1.4.2	Review topographic maps	♦	♦	♦
1.4.3	Review stereo aerial photographs, if available		♦	♦



Hazard/ Measure		H1	H2	H3
1.4.4	Review regional rainfall maps	◆	◆	◆
1.4.5	Perform intermediate field reconnaissance (by qualified geologist)		◆	◆
1.4.6	Review existing ground motion mapping for area	◆	◆	◆
1.4.7	Evaluate landslide potential using expert judgment	◆	◆	◆
1.4.8	Evaluate landslide potential using slope stability maps		◆	◆
1.4.9	Evaluate landslide potential using statistical or empirical analysis		◆	◆
1.4.10	Evaluate landslide potential using analytical methods			◆

Hazard/ Measure		H1	H2	H3
1.5	Earthquake Hazard-Tsunami			
1.5.1	Locate facilities within 20 kilometers from near-shore area	◆	◆	◆
1.5.2	Review topographic maps of coastal areas	◆	◆	◆
1.5.3	Review bathymetric maps of near-shore areas		◆	◆
1.5.4	Review registered records by showing tides local devices	◆	◆	◆
1.5.5	Estimate potential tsunami flooding sewage using expert judgment	◆	◆	◆
1.5.6	Estimate potential tsunami flooding sewage using judgment and tsunami probable sources evaluation		◆	◆
1.5.7	Analyze inundation of area			◆

Table 2.5 Vulnerability Assessment Matrix

Component/ Measure		V1	V2	V3
1	Assess Pipeline Vulnerability to Ground Movement			
1.1	Hazard assessment of passing through areas having potential ground movement considering engineer judgement for various levels of permanent ground deformation	◆	◆	◆
1.2	Detailed analysis of pipeline for few cases according to pipe diameter, wall thickness, displacement direction relative to pipeline and etc.		◆	◆
1.3	Detailed analysis of pipeline for specific site		◆	◆
1.4	Identify strain criteria of pipeline based on existing condition information of pipes, joints and review articles about pipe function		◆	◆
1.5	Identify strain pipeline criteria using numeric mathematical models.		◆	◆
1.6	Identify pipeline analysis acceptance criteria using laboratorial programs and pipe shell finite element analysis			◆
1.7	Evaluation using informed estimates and experience data from past events with minimal field data collection.	◆	◆	◆
1.8	Evaluation of facilities using field data provided from steps 1.2 to 1.5 and detailed and precise data.		◆	◆
1.9	Evaluation of facilities using real field data (according to steps 1.2 to 1.6) and structural analysis results of selected facilities.			◆



Component/ Measure		V1	V2	V3
2	Assess Failures to Critical and Important Buildings			
2.1	Gather information by interviewing company operation managers and building maintenance personnel	◆	◆	◆
2.2	Identify critical functions within buildings, and the damage state that would impair or impede these functions	◆	◆	◆
2.3	Perform general site surveys to assess local conditions and to collect information on the general vulnerability of buildings, their contents and each nearby facilities and supports		◆	◆
2.4	Perform general surveys to assess collateral hazards from off-site sources and nearby structures and equipment		◆	◆
2.5	Assess building performance and supporting facilities using judgment (estimates or informed estimates) and/or experience (statistical) data from past events or using empirical damage evaluation with minimal field data collection	◆	◆	◆
2.6	Review structural drawings, design calculations, foundation investigation reports, and past structural assessment reports to assess building capacity		◆	◆
2.7	Perform independent structural calculations to assess building capacity		◆	◆
2.8	Develop computer-based structural analysis to assess building response			◆

Component/ Measure		V1	V2	V3
3	Assess Storage Tanks			
3.1	Review tank structural integrity using engineering judgment	◆	◆	◆
3.2	Review tank structural integrity		◆	◆
3.3	Assess effects of liquid tank overflow		◆	◆

Table 2.6 Performance Assessment Matrix

Measure		S1	S2	S3
1	Assess System Performance			
1.1	Review system maps	◆	◆	◆
1.2	Review system performance in past natural hazards/events	◆	◆	◆
1.3	Develop system connectivity model of critical operations		◆	◆
1.4	Superposition of system model on various hazard maps (GIS output)		◆	◆
1.5	Estimate system performance using expert judgment	◆	◆	◆
1.6	Run system analysis for finite scenarios (minimal 3 cases)		◆	◆
1.7	Probability analysis and system certainty			◆

Table 2.7 Range of Effort Needed to Perform Hazard, Vulnerability and System Assessments at Different Levels

System Assessment Level		Vulnerability Assessment Level		
1 to 15 days of a full-time employee equivalent				
3 to 10 weeks of a full-time employee		□□	□□	□□
3 to 9 months of a full-time employee				
	□□	□□		
		□□		
		□□		

	□□	Hazard Assessment	□□	■	■	■
			□□	■	■	■
			□□	■		
	□□	Hazard Assessment	□□	■	■	
			□□	■		
			□□	■		

2-3-Seismic Assessment Steps

After pre-assess and identify studies level, to seismic assessment it is required to determine operation performance, seismic vulnerability and hazard and target seismic performance level. These parameters, that will be deterministic of required activities volume to assess each component, involves in assessment steps as follow.

- 1- Identify importance rating and general value of the system
- 2- Calculate seismic hazard of different levels
- 3- Identify operational levels of component/system
- 4- Select primarily seismic assessment method
- 5- Identify primarily vulnerability
- 6- Select detailed seismic assessment method
- 7- Identify detailed vulnerability

2-3-1-Identify Component/System Importance

First step in seismic assessment is classification of sub systems and their components that is done according to table 2.8. After classifying the systems, their relative role and importance in water system will be identified according to table 2.9.



Table 2.8 Categorizing Subsystems and Internal Components

Type	Definition	Impact of Damage in Performance
Principal	Direct impact on system performance	Water outage
Supplementary	Supporting or redundancy impact on system performance	Disturbance in water supply
Secondary	No main or supporting impact on system performance	Insignificant

Table 2.9 Identify Importance by Internal Component and the Entire System Combination

Subsystem or Internal Component \ The Entire System or Collection	Principal	Supplementary	Secondary
High	Very High	High	Medium
Medium	High	Medium	Low
Low	Medium	Low	Low

Achieved importance levels are generally defined as followings:

- 1-Very High: Components that damage to them causes critical condition and lead to abundant casualties and financial losses.
- 2-High: Components that damage to them causes outage, service disruption and financial losses.
- 3-Medium: Components that damage to them causes disturbance.
- 4-Low: Components that damage to them make no impact on system.

2-3-2-Earthquake Hazard Levels

Three seismic hazard levels for seismic assessment are defined as followings.

Hazard level 1: Maximum Operation Earthquake (MOE)

Hazard level 2: Maximum Design Earthquake (MDE)

Hazard level 3: Maximum Considered Earthquake (MCE)

These levels of hazard are equal to the following safety levels that their exact definitions for different importance levels are given in the table 2.10.

- Operation Safety: In this level, probability damages should not cause any disturbance in water utility. Expected performance in this level is non-stop operation of facilities.
- Design Safety: In this level, probability damages may cause temporary and short time disturbance in water utility but it should not lead to main failure, collapse and so on. Expected performance in this level is a minimal partially operation of facilities.
- Critical Safety: In this level, many functional damages may occur but system damage should not occur; so it is necessary to provide countermeasures to reduce secondary impacts. Expected performance in this level is the public life safety.



Table 2.10 Earthquake Hazard Levels

Hazard Levels	Probability of occurrence in 50 years (Return period of earthquake in years)	Safety Level (Performance Level)
Hazard Level 1 (MOE)	99.5 % (75 Years)	Operation Safety (non-stop Operation)
Hazard Level 2 (MDE)	10% (475 Years)	Design Safety (Minimal Partially Operation)
Hazard Level 3 (MCE)	2% (2475 Years)	Critical Safety (Public Life Safety)

2-3-3-Performance Level of System Components

Definition of performance levels by hazard level and importance rating of lifeline equipment is given in the table 2.11.

Table 2.11 Definition of Performance Levels by Hazard Level and Importance Rating

Importance Rating	Hazard Level (Performance Level)		
	Hazard Level-1 (Non-stop Operation)	Hazard Level-2 (Minimal Partially Operation)	Hazard Level-3 (Public Life Safety)
Very High	No damage and disturbance in performance	No casualties Slight damage in equipment but they will continue their performance	No casualties Damage in equipment but, system will maintain its performance No critical positions
High	No damage and disturbance in performance	No casualties Damage in equipment but, system will maintain its performance	No casualties Damage in equipment, with probability of temporary disturbance in system performance No critical positions
Medium	No casualties Slight damage in equipment but they will continue their performance	No casualties Damage in equipment, with probability of temporary disturbance in system performance	No casualties Damage in equipment Main disturbance in equipment and system performance but repairable and restore in acceptable time
Low	No casualties Slight damage in equipment but the system will maintain its performance	No casualties Damage in equipment Main disturbance in equipment and system performance but repairable and restorable in acceptable time	Not necessary



Chapter 3

Seismic Assessment Methods





3-1-Objective Components

Objective components in this guideline are introduced in table 3.1 in two categories of linear and stationed components. From evaluation of Seismic performance point of view, this category is divided into two forms; single performance of each component and system performance of multiple components that make a system. Among stationed components, for buildings such as control and supporting and so on, existing guideline requirements will be used.

Table 3.1. Performance Type of Different Components in Water System

Facilities and Equipment	Elements												
	Wells	Canals	Tunnels	Transmission Pipelines	Distribution Pipelines	Auxiliary Service	Above ground Storage Tanks	Buried Storage Tanks	Treatment plant Facilities	Diversion Structures	Pump Stations	Computer and Electrical Equipment	Administrative and Supporting and Performance Buildings
Performance	Component	Component	Component	System	System	Component	Component	Component	System	Component	System	Component	Component

3-2-General Approach of Vulnerability Determination

General approach of lifeline vulnerability and seismic retrofitting determination is illustrated in figure 3.1. This approach includes four activities:

- 1- Gather information of structures, facilities and equipment such as relevant information of individual components and systems with a view to the process and performance.
- 2-Review geotechnical data and seismicity of region containing soil characteristic investigation and secondary outcomes such as sliding, liquefaction and faulting; and study earthquake history and active faults.
- 3-Review seismic vulnerability
- 4-Seismic retrofitting if necessary



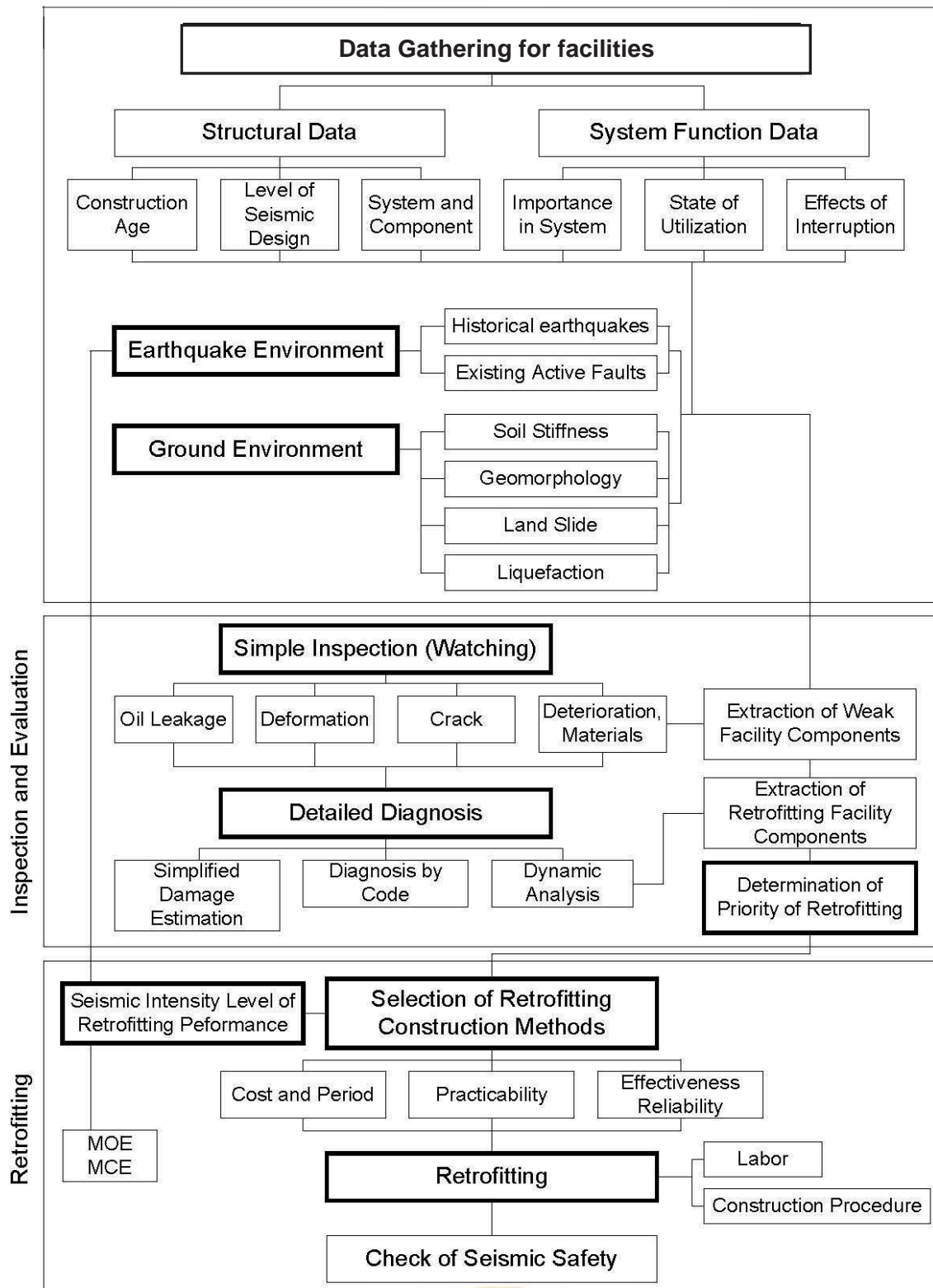
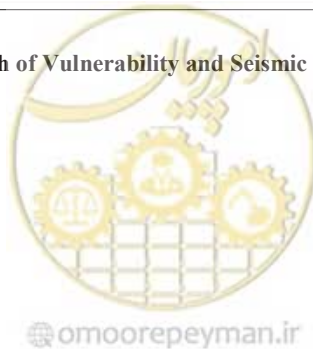

Figure 3.1. General Approach of Vulnerability and Seismic Retrofitting Determination



3-3-Seismic Assessment Methods of Components

Primary and detailed seismic assessment methods for stationed structures such as buildings, non-building structures, non-structural elements and equipment and, linear and network structures are given in table 3.2.

Table 3.2. Seismic Assessment Methods of Components in Different Levels

Component	Assessment Methods Level 1	Assessment Methods Level 2	Assessment Methods Level 3
Building structures	Rapid assessment	Rapid assessment	Detailed assessment
Non-Building Structures	Qualitative assessment worksheet and scoring method	Seismic behavior control by reviewing design documents and using simple and equal static code methods	Analyze of dynamic and interaction behavior by analytical and numerical modeling
Equipment	Qualitative assessment worksheet and scoring method	Seismic general stability control by reviewing design documents and using simple and equal static code methods or empirical methods based on failure curves	Analyze of dynamic and interaction behavior by analytical and numerical modeling
Non-Structural Elements and Building Internal Equipment	Qualitative assessment worksheet	Qualitative assessment worksheet	General stability control using simple and equal static or empirical methods
Above and Underground Transmission and Distribution Pipelines	Qualitative assessment worksheet and scoring method	Seismic general stability control under geotechnical hazards (sliding, faulting, liquefaction, ...) and nearby structure impact by reviewing design documents and using simple and empirical methods	Analyze of dynamic behavior under geotechnical hazards (sliding, faulting, liquefaction, ...) and nearby structure impact by analytical and numerical modeling

3-3-1-Seismic Assessment of Buildings

Further to what has stated to identify assessment parameters, key and effective factors in building performance assessment are as followings:

- Economic value of structure and remained years of its operation life
- Building usage include number of people exposed to hazard inside the structure and structure failure factors that cause releasing hazardous material and fatalities outside the structure.
- Building performance and economic and social impacts in case of loss of service due to damage from earthquake
- Building historical importance of structure and seismic retrofitting impacts on cultural and heritage resources
- Definite seismic hazard of the specific site
- Relative cost of retrofitting regarding its incomes.

Primary seismic assessment in the levels 1 and 2 of concrete, metal and masonry buildings will be done using instruction No.364 from president deputy strategic planning and control as the title of rapid

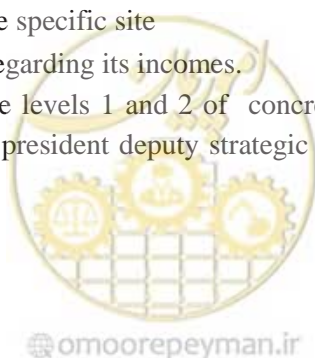

seismic evaluation of existing buildings, that is used for rapid seismic evaluation for steel and reinforced concrete buildings.

Primary seismic assessment in the levels 1 and 2 of masonry buildings will be done using rapid qualitative evaluation method presented in chapter 3 of instruction No. 376 from president deputy strategic planning and control for masonry buildings.

Detailed assessment in the level 3 of concrete and metal buildings will be done using term of reference in publication No. 251 as the title of term of reference for seismic retrofitting of existing buildings and Instruction No.360 from President deputy strategic planning and control as the title of instruction for seismic retrofitting of existing Buildings.

Detailed assessment of existing masonry buildings will be done using instruction for vulnerability analysis and seismic retrofitting of existing unreinforced masonry buildings (building undersecretary of ministry of housing and urban development).

3-3-2-Seismic Assessment of Non-Building Structures

Primary seismic assessment in levels 1 and 2 and non-building structures, that is performed by components, could be done by these methods:

- Review primary seismic design documents considering as-built drawings and present situation of structure, if available
- Inspection by provision and using seismic worksheets considering type of each structure and evaluation by qualitative scoring method
- Use simple and equal static models and methods and control general seismic stability

Primary assessment of non-building structures usually is not consisting of system inspection. In case of vulnerability of components in this step, detailed assessment will be done by both component and system approaches.

Detailed assessment of level 3 for non-building structures will be done by modeling and numerical analysis. This survey includes studying dynamic behavior and interaction of structure. Using detailed method for complicated structures or with indefinite dynamic behavior or having significant interaction with environment or with the other structures is necessary.

3-3-3-Seismic Assessment of Equipment

Primary assessment of equipment will be done by following approaches:

Review of seismic control documents considering equipment condition that contains documents of seismic examinations and internal performance control by manufacturer.

Quantitative Scoring Method

- Using simple and equal static code methods and seismic general stability control

Primary assessment of equipment usually there is not including of system inspection.

In case of vulnerability of components in this step, detailed assessment will be done by both component and system approaches.

Detailed assessment of equipment will be done by modeling and numerical analysis. This survey includes studying dynamic behavior and interaction of equipment. Using detailed method for complicated structures or with indefinite dynamic behavior or having significant interaction with environment or with the other structures and equipment is necessary.



3-3-4-Seismic Assessment of Non-Structural Elements

Seismic assessment of architectural elements and internal equipments of buildings like walls, cabinets and false ceiling and internal facilities such as piping and canals will be done in one-step and based on requirements and guides as followings:

- Instruction for seismic retrofitting of existing Buildings, publication No.360
- Instruction for seismic design of water lifeline
- Other valid references introduced in this guideline

3-3-5-Seismic Assessment of Network and Pipeline

Seismic assessment of network and pipeline will be done in two component steps to determine vulnerability of each element of network and system to identify vulnerability of overall pipelines or network limit.

Primary assessment of pipeline and network components in level 1 can be done by the following methods:

- Review seismic design documents of network, if available
- Provision and using seismic worksheets considering types of network components and using qualitative scoring method
- Using simple and equal static code methods and seismic general stability control of pipeline or network components
- Using existing vulnerability curves of components

Primary assessment of pipeline and network components in level 1 can be done by formulation of vulnerability compound based on reliability method.

Component detailed assessment of level 3 for pipelines and network can be done by analytical method using computing and numerical model.

Component detailed assessment of level 3 for pipelines and network can be done by formulation of vulnerability compound based on reliability method.

Compound formulation based on reliability method may be done using guidance of appendixes of publications No. 512 and No.513.

3-4-Inspection in Qualitative Assessment

Inspection and completing qualitative assessment of components is one of the important parts of seismic assessment in levels 1 and 2. Consequences of this activity, that yield to determination of primary list for vulnerable components and qualitative rate of vulnerability have a great impact on type and capacity of continuing studies.

An engineer or a group of experienced and qualified engineers should do local inspection and adding up the results. Total steps of this activity are as the followings:

- Held meetings with employers, technicians, standard authorities, safety engineers and other interested parties to discuss and review about targets of the inspection and give the necessary facilities to the inspection group.
- Identify and provide a list of equipment, structures and other target components
- Classify vulnerability modes of target components
- Provide or complete inspection worksheets



- Coordinate with process and operation safety group
- Collect local data such as seismic hazard, position of faults, existing soil borings and the other relevant geotechnical data.
- Local inspection of components and filling in the worksheets and documentation of obtained observation and information
- Revise maps, if necessary, will be used to control sufficiency of reinforced concrete structure, determine anchorage details or identify cases which sight survey is not possible due to sight limitation like fireproof covers, isolation, etc.
- List weak or suspicious elements for employers or standard authorities containing sufficient information
- Identify outcomes due to failure of elements

During a destructive earthquake, there is probability of damage to facilities outside the site and their destruction in a long-term period. In these cases, providing things such as supporting power equipments and water tanks seems reasonable in seismic assessment and retrofitting. Local inspector teams should specify existence of other emergency systems effective in system performance to reduce earthquake influences especially necessity of alarm and fire extinguishing, telecommunication and preventive systems to perform non-stop performance after the earthquake.

Main technical considerations in inspection are:

- Ground seismic hazard level: In areas with less seismic hazard, structures may be designed for lateral load other than earthquake such as wind and may be resistant to respond to the earthquake, however, it may also occur displacements that lead to failure in low seismic levels.
- Secondary hazard intensity (faulting, soil movement and land sliding): Inspection team should particularly notice the existing faults near the site. Locations where there are probability of displacement and damage to buried pipelines and equipment relying on different structural systems should be considered. In position that faults pass through site location, evaluation of inspection team should be completed by additional geotechnical researches or the other studies.
- Applicable codes when constructing; Applicable codes and seismic design methods may have a great change than primary design time of that unit.
- To assess older facilities more attention should be paid to the existing damages from structure destruction such as dented steel, damaged concrete, corrosion and etc.
- When general quality of repair and maintenance is not appropriate, local inspection team should revise the details such as lost bolts and nuts, unrepaired failures, field changes, modifications, especially in transfer path of structure load and in conjunctions.
- Safety process engineers and employers should be informed and ensured of safety primary investigation, pollution or economical and environmental consequences of damages via local inspectors.
- Local inspection team should always supervise areas susceptible to corrosion. Areas susceptible to corrosion are associated to location of corrosive materials like acids and water collection place too. The other cases that corrosion may be problematic, is where the concrete lining is separated and bars are exposed to environmental condition.
- During inspecting, engineer can also investigate installed problematical facilities. These problems may be observed in welding or installing expansion anchorage bolts. For instance, if length of expansion anchorage is not sufficient, it may not resist in extent of its design traction capacity.

- It may move a piece of system, structure, storage cabinets, furniture, and storage devices during earthquake. Due to movement and then colliding of these elements to a system or part of it, it will cause damages that are known as seismic interaction. Local surveys about possible interactions are one of the best cases to investigate performance of elements. Interactions often occur when there is no sufficient distance between two elements. In addition, it may occur due to slipping of unanchored facilities, movement of hanging pipes or cable trays, arising electrical panels and colliding to the panels nearby, walls or structural members. Another example include relevant hazard to transit platforms with sharp supports. Structure rupture and overturning when different elements fall because of inadequate anchor from the top, and then clash to the other devices indicate the other case of interaction.
- For local inspectors asymmetrical displacement is important more about facilities connected to different structural systems. Engineers should be informed of possible displacement positions of facilities. These positions include something like joint pipes, ducts, conduits, pipes, etc. In these cases, facilities should have sufficient flexibility against movement. Flexibility is a key characteristic to resist the vulnerability. The characteristic is specifically important in using different foundations for equipment, when equipment is not anchored.
- One of the significant subjects is the automated alarm and extinguishing fire system. Locating water sensitive equipment under the head of sprinkler may interrupt their function.
- Vulnerability investigation of existing buildings adjacent to the distribution network components and hazard of their clash to the network components, in case of destruction, should be assessed. For this purpose, at first the category of buildings should be identified which are sufficiently close to distribution network components and, if in destruction of total or some elements there is a clash hazard to the network components. After identifying hazardous building near the network, the building should be assessed in the next step. Seismic assessment of buildings near distribution network by case should be based on associated instructions (instructions No.360 and No.364 of president deputy strategic planning and control, for buildings with reinforced concrete or steel structure and instruction No.376 for masonry buildings) and if possible, using quantitative methods is recommended. The purpose performance level in evaluation of these buildings, for design hazard level according to this guideline, life safety equal to collapse threshold and highly important components should be considered. If there is no possibility of quantitative assessment for evaluation of target building, complementary qualitative assessment is necessary according to the instruction stated above. About highly important components of the network, evaluation of the buildings nearby, by quantitative methods is obligatory.

3-5-Gathering Required Information in Detailed Assessment

A planned process should gathering required information in quantitative assessment. Existing references to determine and gather required information include the followings:

- 1-Existing documents in different steps of design, operation and periodic repairs: Existing documents should be compared objectively with present condition of network and be updated, if necessary.
- 2-Visit and take information using objective methods and required measurements: To this purpose, if necessary, should perform sounding and lining destruction and upper layers (with no

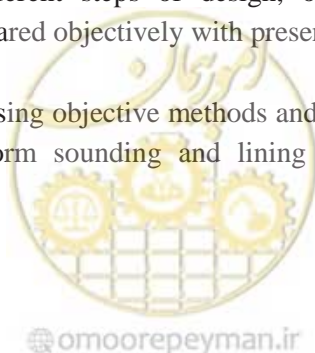

interruption or weakness in component performance or behavior) and identify required characteristics and parameters.

3-Required tests: When necessary and in absence of the required information based on existing documents or catalogs, required information should be provided and gathered using experimental methods. The most important cases to use test methods is determining soil and site required characteristics and mechanical specification of materials. Generally non- destructive testing is preferred. If there is a need to do a test on joint devices like bolts or insulators and so on, if possible, the testing device should be replaced with a similar one. Anyway, during sounding or testing any of existing elements in network from damages or weakness should be avoided.

3-5-1-Gathering Design and Operation Documents

In the beginning of seismic assessment study, structural documents of facilities such as buildings, non-building structures and equipment should possibly be gathered and revised precisely. Also, operational drawings should be matched with what has performed, and should be updated in case of too much unconformity. Collecting data associated to changes and possible repairs and effective events on facility behavior is also necessary. Information about material and soil tests and also hazard analysis studies should be possibly gathered and revised.

3-5-2-Objective Inspection and Derivation of Obvious and Effective Difficulties

In this stage of collecting data, studies and surveys should be done to record obvious and effective difficulties that cause a definite and clear weakness in seismic behavior of facilities. Comparing operational, as built and installation drawings with present condition of facilities in this step is necessary.

3-5-3-Material and Soil Experiments and Hazard Analysis Studies

This stage of collecting data should be done after employer`s approval, if above surveys do not verify that existing documents and data are not adequate for primary or detailed assessment in consultant engineer opinion. In table 3.3 it has mentioned the conditions which performing material or soil experiments and their levels is deemed necessary.

Definition of conventional and comprehensive experiments for buildings is according to the publication No.360.

In this guideline there is no specified definition for the above experiments and required experiment level in these cases should be identified by the consultant engineer`s opinion and employer`s approval.



Table 3.3. Required Material and Soil Experiments

Relative Importance of System	Material and Soil Data	Required Experiment Level for Material and Soil
Very High	Available	Conventional
	Not Available	Comprehensive
High	Available	-
	Not Available	Conventional
Medium	Available	-
	Not Available	Conventional
Low	Available	-
	Not Available	-

3-6-Seismic Assessment by Structure Modeling and Numerical Analysis

Structure modeling and numerical analysis methods are based on identifying and comparing needs-seismic capacity of equipment and structures and their joints.

Structure modeling and numerical analysis methods include two following basic aspects.

- Provide appropriate model considering mechanical and dynamic characteristics
- Seismic loading and structure numerical analysis of provided model

Structure numerical analysis methods recommended in this guideline are:

- Equal Static Method
- Spectrum Method
- Time History Method

3-6-1-Equal Static Method

In seismic analysis of the equipment which first mode vibration impacts on them can be accepted as a dominant mode, it is recommended using equal static method according to the requirements of the non-building structures section of the code 2800.

For equipment with natural period less than 0.03s imposed force, obtained from ZPA acceleration multiply with mass of different components to their mass center, is acceptable; with no need to any intensification factor.

3-6-2-Spectrum Method

For complex methods with numerous vibration modes, sufficiently apart from each other, it is recommended using spectrum method according to the requirements of non-building structures section of code 2800.

3-6-3-Time History Method

In seismic assessment of complex equipment with vibration modes, close to each other, it is recommended using time history analysis according to the requirements of non-building structures section of code 2800 to control achieved results from spectrum method.

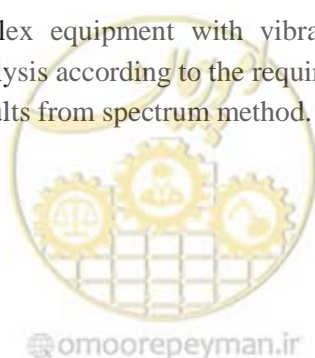

3-7-Considering Seismic Interaction Effect of Systems

Seismic interaction of systems is a set of effects on seismic behavior and aggravating outcomes due to earthquake containing undesirable change in dynamic characteristics from structural interaction, collision and, falling of surrounding systems on each other, relative displacement of the systems nearby and changes in environmental and operational conditions that cause disturbance in system or personnel's performance.

Common reasons of interaction can be categorized as followings:

- 1-Vicinity: Any effects that cause loss of function due to neighbor systems include collision, relative deformation and structural interaction.
- 2-Rupture and Falling: Any effects that cause loss of function due to failure and rupture and falling.
- 3-Sprinkler: Effects due to rupture of pipes or function of fire extinguishing sprinklers that may cause short circuit or unavailability to the other components.
- 4-Flooding: Effects due to submerging of systems and unavailability to them
- 5-Fire: Effects due to fire such as smoke diffusion, destruction of systems

3-8-Acceptability Criteria

Obtaining equipment vulnerability is dependent on exceeding total need obtained from combining seismic loading and the other applicable loads from seismic capacity of components.

3-8-1-Imposed Forces Combinations

Required forces combinations for seismic vulnerability assessment of non- building components are generally as followings:

Dead loads + operation loads + horizontal seismic load (in two directions independently) + vertical seismic load (in two directions independently).

To combine above load in design hazard level, seismic loads (horizontal and vertical) should be multiplied by load coefficient equal to 1.4.

3-8-2-Stability Controls

About anchored components and equipment further to investigate needs and seismic capacity resistance, control of overturning, sliding and displacement is necessary.

Unanchored equipment and components should be controlled against imposed seismic forces, for the aspect of overturning and sliding. Values of minimal required safety factor for overturning and sliding in both hazard levels are respectively 1.75 and 1.5.

3-8-3-Acceptability Criteria in Nonlinear Dynamic Methods

Generally in nonlinear dynamic methods, assessment and acceptability of various components will be done by criteria consist of force and displacement combination. In distribution water network considering target function of equipment and network component, in case of performing nonlinear analysis, stresses and created internal forces in non-ductile elements (controlled by force) should be controlled similar to linear methods (given in previous sections). In ductile elements entering nonlinear limits, created displacements and rotations should be in a range that do not cause disturbance in expected function of assessing component. Identifying these cases should be done by technical characteristics of equipment and professional's judgment.

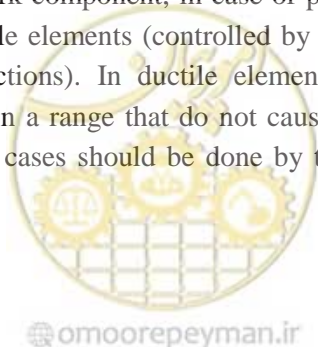

Chapter 4

Seismic Retrofitting Procedure



4-Seismic Retrofitting Procedure

4-1-Retrofitting Prioritizing

Retrofitting Prioritizing will be done considering following indexes.

- Index Level R
- Expected Performance Level Change
- Retrofitting Cost
- Operational Facilitation of Retrofitting Method

General procedure to identify retrofitting prioritizing is based on risk analysis. To perform this analysis it is necessary to identify outcomes of not retrofitting based on results of vulnerability studies and then make decision. Outcomes of not retrofitting will be reviewed in five categories: fatalities, probability of occurring political and social crisis considering power outage time, direct financial loss to facilities, economical loss due to lifeline service loss and environmental loss. In fact, these criteria indicate general safety of structure or equipment. The highest retrofitting priority will be allocated to two first cases. In the other cases, comparing retrofitting cost and forecasted loss costs, risk of not retrofitting will be determined and the decision will be made based on it. In performing risk analysis, different failure modes and different levels of retrofitting can be compared.

4-2-Seismic Retrofitting Procedure

Seismic retrofitting procedure of structures and equipment that is a trial and error method will be done after verifying vulnerability of structure and based on these steps:

- 1-Select retrofitting method based on failure mode of equipment and structures and their required performance
- 2-Apply changes due to every retrofitting method in structural model and reinvestigation of vulnerability to achieve appropriate desired performance
- 3- Compare acceptable retrofitting methods based on indexes such as cost, time, and operational facilitation as value engineering and prioritizing retrofitting methods for any structure and equipment
- 4-Prioritizing seismic retrofitting of system components based on section 4.1



Chapter 5

Rehabilitation Methods



5-1- Rehabilitation Method Selection Approach

Methods of seismic outcomes reduction for structures and equipment could be generally categorized in two categories:

- Hardware methods as structural rehabilitation and modification and finally rebuilt
- Software methods as operation program change, expected performance level change, and increasing safety and decreasing probability of occurring secondary events

Type of seismic rehabilitation method is dependent on dominant failure mode of structure or equipment. So selecting appropriate rehabilitation method is directly related to validation of vulnerability assessment results. Failure mode and the damage rate should be identified completely in this study. Naturally based on earthquake level, failure mode could be different. This should be considered in selecting rehabilitation method so that all probable failure modes by performing proportionate rehabilitation actions could be controlled.

In failure mode investigation and giving rehabilitation methods, all primarily and secondary damage modes should be considered. Secondary damage modes include permanent ground deformation, flood, interaction and collision of structures, and debris fall from other components on them and etc.

5-2- Failure Modes and Type of Rehabilitation Method

In this section general seismic rehabilitation methods of water structures and equipment is suggested focusing on transmission and distribution pipelines and the other buildings related to them which have the most failure experience with introducing observed failure modes in the past earthquakes.

5-2-1- Reservoirs

Water reservoirs are various in type and include different dams; fill, concrete, masonry and the other dams, under ground reservoirs, in small scale; above ground concrete, metal, buried, partially buried tanks and in smaller scale; concrete and steel elevated tanks.

Seismic safety assessment and rehabilitation of dams will be done based on Guideline for safety assessment and emergency action plan for dams and appurtenant structures (pub. No.370-a, Bureau of engineering and technical criterias for water and wastewater). In case of medium and small tanks analytical assessment will be done based on pub. No.123, Management and planning organization.

Elevated tank structure which is made from reinforced concrete, or pre-stressed concrete and steel, should be sufficiently safe and sealed.

Above ground reservoir shape can be cylindrical, rectangular and so on. Vulnerability modes of this kind of reservoirs which should be considered in rehabilitation, mainly are as followings:

- (1) break or leak from pipe joint or reservoir inlet and outlet valves
- (2) breakage and crack in tank bottom slab
- (3) failure in inertial pillar and wall joints to slab
- (4) tank ceiling failure and collapse

in case of elevated tanks main vulnerability modes are:

- (1) pipe or joint valve breakage or water leakage from inlet or outlet valve or pipe to tank.
- (2) Tilting or toppling
- (3) Failure in feet and sustaining structure elements as buckling or yield

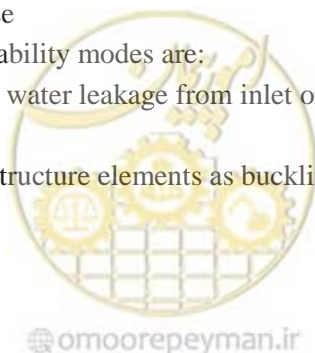

(4) Tank wall buckling in metal elevated tanks

Failure modes, causes and conventional seismic rehabilitation methods is listed in table 5-1.



Table 5-1-Seismic Rehabilitation Guide for Above Ground Water Reservoirs and Concrete and Metal Elevated Tanks

Component	Probable Failure Mode	Failure Cause	Rehabilitation Method
Concrete rectangular or cylindrical buried and partially buried Tanks	<ul style="list-style-type: none"> ← Pipe or joint valve breakage or leakage from inlet and outlet valve or pipe ← Failure and cracking of interior pillars in connections to ceiling and floor slabs ← Cracking in floor slab and its connection to walls ← Out of plate breakage and cracking in connections of peripheral walls to ceiling and floor slabs. ← Ceiling destruction 	<ul style="list-style-type: none"> ← High relative deformation between tank and pipe due to sliding on slope or imposed ground movements to pipe and valve support ← Inadequate Lateral stiffness of structure or weakness in design and ductility of pillar ← High ground deformation and settlement or slope sliding ← Unequal or inadequate lateral stiffness or low resistance against pressure and impulse due to dynamic hydraulic impacts ← Using one-way ceiling slab with hinged joints like tile and joist 	<ul style="list-style-type: none"> ← Stabilize seat location slope of tank and modify pipe and valve supports and using expansion and flexible joint ← Strengthen interior pillar in connection to ceiling and floor and increase lateral stiffness by additional interior or exterior shear wall ← Retrofit foundation soil or strengthen structure footing by injection or piling or similar ways and increase lateral stiffness by additional interior or exterior shear wall ← Add interior and exterior lateral anchorage or strengthen structure members and increase lateral stiffness by additional interior or exterior shear wall ← Strengthening ceiling slab connections and develop one-way or two-way bending function
Elevated concrete tank	<ul style="list-style-type: none"> ← Pipe or joint valve breakage or leakage from inlet and outlet valve or pipe ← Titling or toppling ← Failure in feet and sustaining structure elements 	<ul style="list-style-type: none"> ← Inadequate base stiffness and high bending deformation, deformation and foundation settlement, resonant due to reverse pendulum function ← Inadequate lateral base stiffness, buckling and member yield due to resistancy weakness 	<ul style="list-style-type: none"> ← Feet strengthening and control of dynamic behavior and resonance ← Strengthen and resonance, using expansion and flexible joint, foundation and tower footing strengthening, reducing tank maximum level ← Feet strengthening and control dynamic behavior and resonance ← Strengthen elements and base anchorage joints or base pillars by FRP or metal jacket or metal bond
Elevated metal tank	<ul style="list-style-type: none"> ← Buckling of tank body ← Pipe or joint valve breakage or leakage from inlet and outlet valve or pipe ← Titling or toppling ← Failure in feet and sustaining structure 	<ul style="list-style-type: none"> ← Inadequate shell stiffness to withstand hydraulic dynamic and vibration forces ← Inadequate base stiffness and high bending deformation, foundation deformation and settlement, resonant due to reverse pendulum function ← Inadequate lateral stiffness, high foundation failure and 	<ul style="list-style-type: none"> ← Shell strengthening or adding stiffener or FRP lining or metal bond ← Feet strengthening and control dynamic behavior and resonance, using expansion and flexible joint, foundation and tower footing strengthening, reducing tank maximum level ← Feet strengthening and control

Component	Probable Failure Mode	Failure Cause	Rehabilitation Method
	elements	settlement, resonant due to reverse pendulum function ← Inadequate lateral base stiffness, buckling and member yield due to resistancy weakness	dynamic behavior and resonance ← Strengthen elements and base anchorage joints or base pillars

5-2-2- Treatment Plant and Pump Station

Treatment plant and pump station structures mainly include building structures and tanks and equipments. Further to pub. No.360 for structural building, for tanks similar to section 5-2-1 and for equipment, requirements of this guideline and the other lifeline guidelines can be used.

5-2-3- Transfer and distribution Pipeline

Pipelines are commonly under ground but in some situation, above ground systems are used by supports. Pipeline may cross rivers or the other obstructions like roads and railroad bridges. In these cases design condition of pipes is affected by the obstruction. If these structures have no sufficient capacity to maintain pipeline and other design loads, pipeline support and other maintenance facilities would be appropriate and cost effective.

5-2-3-1- Failure Modes

Based on categories of vulnerability and failure modes in the past earthquakes:

- Damage form is different in various kind of pipe.
- In ductile cast iron pipes common pipe joint is often detached and there is water leakage .
- In cast iron and hard PVC pipes, separation and breakage is observed in the pipe body.
- In steel pipes welded joint and pipe body there were breakage. Also in bridge pipe support and in pipe body breakage has observed in some places.
- In dependent segment, damage to fire hydrant and breakage in gates and loosening edges and also breakage in body has observed.

Permanent ground motions are the most hazardous events for the pipeline. Maximum strain values from permanent dislocation are in the motion boundaries. Maximum hazard potential of settlement is in locations with the most settlement differences. Liquefaction hazard is high in common surface between liquefied and non-liquefied material. Also, there is faulting hazard in primary way of surface breakage and more landsliding hazard in sliding boundaries.

Main failure modes in buried pipelines are:

- Breakage
- Peripheral crack
- Cross cracking
- Pipe body breakage
- Split in joints

More damages in pipe joints are breakage and removal and separating parts of joints.(Figure 5-1)



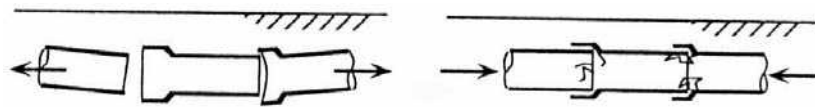

Figure 5-1- Breakage in Pipe Joint

In soil liquefaction conditions considering raising and settlement, because of layer compression there is high distortion as shown in the figure below.

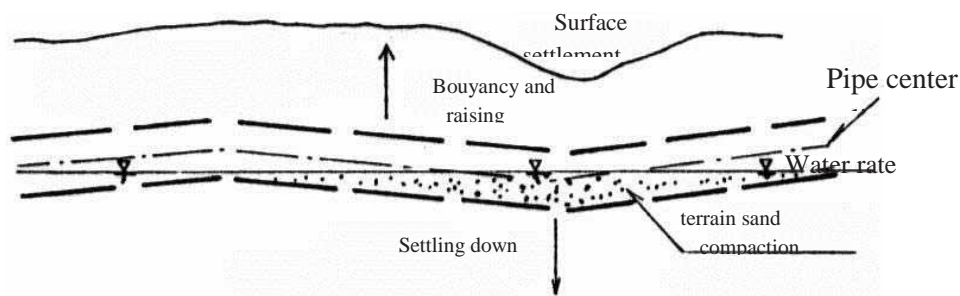

Figure 5-2- Pipe Distortion in Liquefaction Conditions

Failure modes include various failure rates as shown in the table below.

Table 5-2- Failure Modes to Pipe

Failure mode	Rate (Limit)		Ground surface structure condition
	High	Low	
Failure to joints between bricks and joint parts			soft lands, residential house construction land, variable portions and ground surface and surfaces which liquefaction is easily occurred and the parts near manhole
Pipe body failure	failure cracking vulnerability (vertical to horizontal) (cracking extent)		
split in central line of pipe and separation of pipes	flexural of pipe (right and left)	flexural wide split in central line of pipe (up and down) wide separation of pipe	Ground surface situation change evidently such as what has stated above
Raising pipe body (just in liquefaction)	Split in pipe axis and raising flexural (up and down, left and right)		Ground surfaces where liquefaction is done easily

Different pipe failure modes due to ground failure is schematically illustrated in figure 5-3.



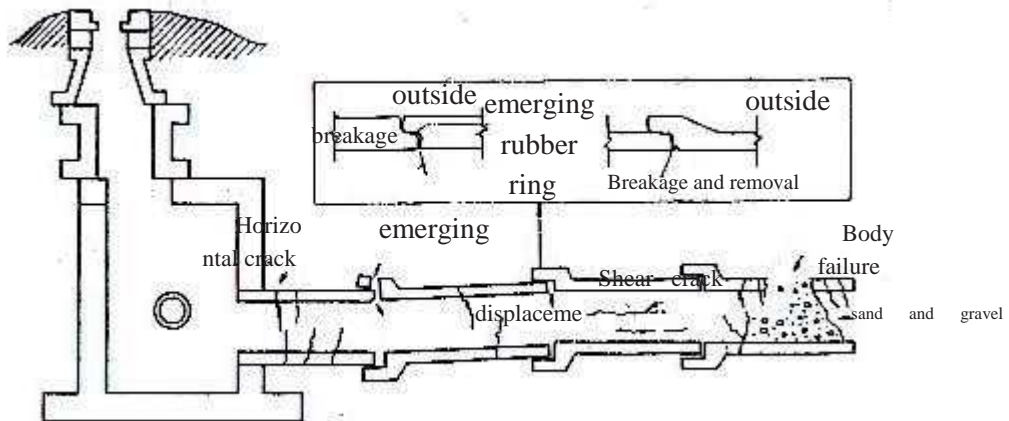

a) Up-down displacement in pipe axis direction (pipe and ground cross section)

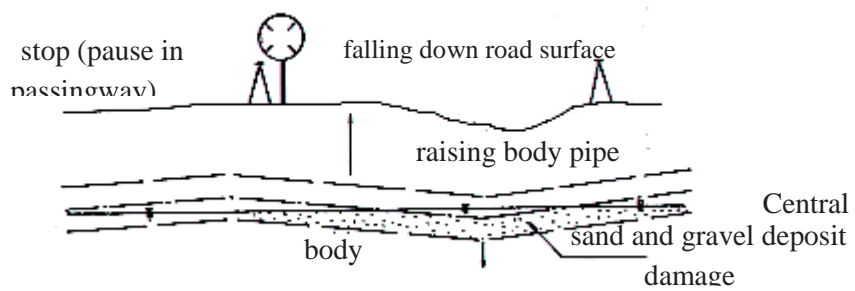

Pipe flexural (up and down)

b) High displacement and pipe segments separation

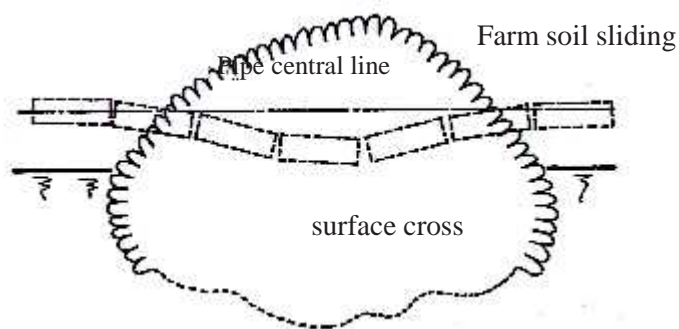

c) High displacement and pipe segments separation



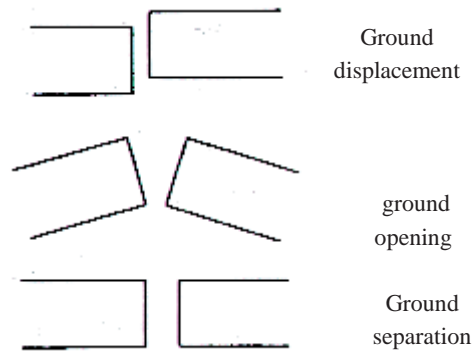

d) Joint displacement, joint opening and their separation

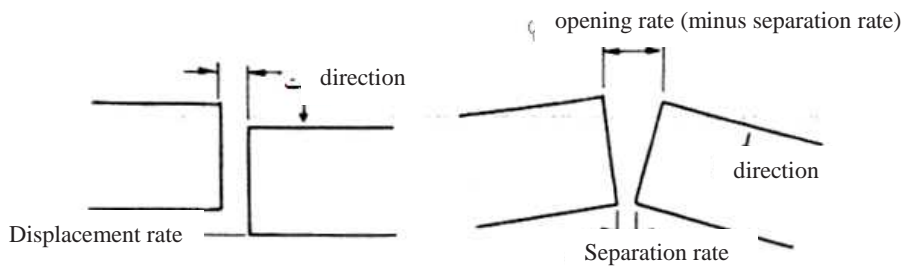

e) Pipe body damage

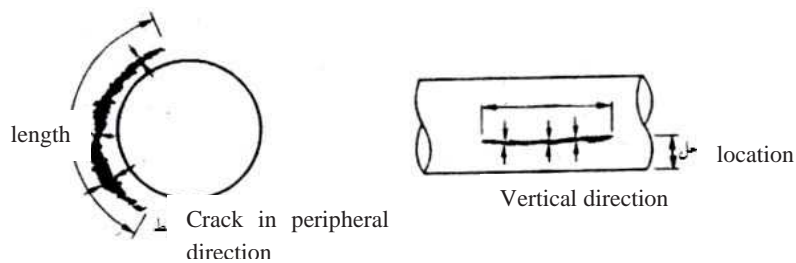

f) Split and displacement in pipe central line and separation

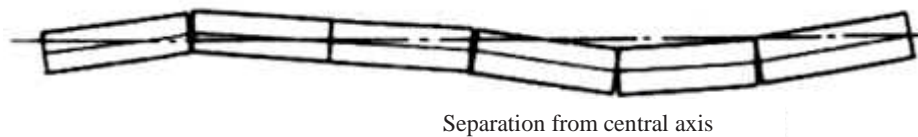
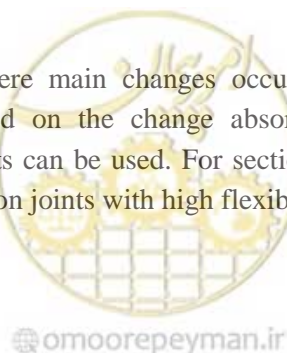

Figure 5-3- Pipe Failure Modes

5-2-3-2- Rehabilitation Methods

Buried pipeline safety in places where main changes occur like land cracking and soil lateral movement, should be controlled based on the change absorption. In order to prevent pipeline displacement and rupture expansion joints can be used. For sections which bending force imposed (like building entrances and joint box) expansion joints with high flexibility should be used.



5-2-3-2-1- Seismic Rehabilitation of Fault Crossing Pipelines

To retrofit fault crossing pipelines, characteristic change, structural measures, systematic measures, and design change according to fault displacement rate could be mentioned. These measures is categorized to hardware and software measures.

- (1) Hardware measures: taking these measures even after the earthquake, maintaining pipeline performance is possible. Fault displacement s in scale low to medium are included.
- (2) Software measures: fault displacement rate in scale medium to high, which are not adaptable to hardware measures, are included. In this case some damages are inevitable. taking this measure aimed to maintain function or minimizing loss of function.

If fault location is not determined clearly, measures such as section magnifying, dualizing, ductility, and separating inertial facilities and structures is taken for under ground structures in that situation. If taking these measures is difficult in technical notice, these measures with software measures like system change will be taken.

Table 5-6- Classification of Measures

Estimated Fault displacement rate	Measures	
Low	Hardware measures	Design, characteristic change
↓		Structural measures
↓	Software measures If it is difficult in technical notice	Systematic measures
High		Design change

Structural measures and design change and characteristics or on the other hand hardware measures, according to the content are classified to pipeline and surrounding soil measures.

Following measures is possible as combining some cases together.

- (1) Characteristic changes of integrate pipeline like pipe body material resistance and deformability or replacing with better various pipes.
- (2) Characteristic changes of jointed pipeline with replacing flexible joints and enhancing pipe body with replacing better pipes.
- (3) Develop bending pipe to increase permissive displacement
- (4) Using dual pipe structure with lined pipe
- (5) Using lining material with displacement absorbability outside
- (6) Using material promoting pipeline surface slipping
- (7) Using flexible lining material inside
- (8) Convert to above ground piping

Cases (1) and (2) above will cause pipeline degree promotion in design steps. In case (3) by developing bending pipe in 2 point of fault crossing, incident angle of pipeline and fault can be under control. If soil stiffness around pipeline is high, distance decrease and increase between 2 points due to fault motion could not be adjusted by tension/ compression of straight pipe. By ability of bending angle decrease and increase in joined bending pipe, needed adjustment could be achieved toward huge displacements. Depending on incident angle of fault and pipeline, expansion joint will be effective. Cases (4) and (5) state fault displacement with casing and gap between pipeline and lined pipe. Case (6) decreasing friction resistance between soil around and pipeline reduces maximum soil clamp force in the axis direction and pipeline deforms identically in a wider space. Application of these material is possible

in pipe and filled soil or slipping colored material and sheet previously used in lining. Main purpose of these measures (5), (6) is stability toward dynamic fluctuation component but, it is further effective on fault. measure (7) disperses soft lining material inside the pipeline crossing fault, which maintain the function even with breaking pipeline. measure (8) changes under ground pipeline to above ground piping from the section where fault movement is forecasted. In under ground case if surface soil stiffness is high, pipeline strain will focus on fault crossing side but by change to above ground piping with all above ground pipeline, there is possibility of displacement absorption.

Also, in case of joining bending pipe and flexible joint to buried pipe and using lining material, if fault location is not correctly identified the material will not show appropriate effect. But in above ground piping certainly displacement absorption equipment will be effective. This measure will be very effective if determining the exact location of fault is not possible.

About surrounding soil measures:

- (1) Use flexible fillet material
- (2) Widen excavated section when installing pipeline

Based on (1), (2) filled section is used as absorbant material toward fault displacement. But because of settling, ground surface deformation and occupied space by road, there is some limitations. Mainly these measures are adopted with displacement in vertical direction of pipe axis, so if displacement in horizontal direction is dominant, in case soil clamp force in axis direction is high, they will be used with expansion or elastic joints.

If preventing damage of buried pipe is difficult in technical notice, systematic measure and design change will be taken. In systematic measure inevitable damage in buried pipe due to fault motion is previously assumed. These measures aimed to maintain function and minimize functional loss. Design change which is mentioned here, means modifying main design. This change will be done if forecasted fault displacement rate is high and adopting with measures stated above is not possible.

About systematic measures:

- (1) Installation emergency shutoff valve
- (2) Installation anchorage point
- (3) Development of additional length by making loop
- (4) Development of supporting facilities.

In measure (1) by installing shutoff valve in both side of area which forecasted to cross the fault, water leakage and secondary events are prevented. When occurring earthquake which cause physical damage to the mentioned pipeline, probability of enlargement in nearly ground shaking will be more. So, in nearby pipelines more damages will occur. Fault crossing valve is installed with purpose of blocking to decrease nearby damages. Probability of damages to pipeline on the fault line is so high. Hence, fault will be a wide block boundary so, there is a need to telemeter to transmit required data such as pressure, flowrate, and soil displacement rate; and telemeter equipment of valve.

Case (2) limits fault displacement impact on pipeline between two anchorage point. Of the structural measure view point, equal allocating of fault displacement in a wide area the pipeline and its strain control is very ideal. But if because of surrounding structures, high soil stiffness, connections in pipeline there is no possibility of performing, pipeline space restriction which accept such an impact is reasonable. Elastic joint and flexible joint are included in the structural measures, but by installing a brake on them to reject unexpected external force, systematic measures will be taken.



In case (3) even if function of purposed way is lost due to damage from fault with connection way between systems with the other way or remained way, possibly the connection function of both sides of fault will be maintained.

About design change:

(1) Deviation of area where fault displacement is forecastable.

(2) Participating with wide multipurpose channel, constructing in large cross section cover

In measure (1) if by shortening distance from crossing fault, appropriate adoption with structural measures is not possible, or in systematic measures adoption with secondary events is not appropriate, constructing way in the mentioned area should be avoided.

In measure (2) if adaptation in single vital facility level such as buried pipeline is not possible, cooperating the other lifelines, pipeline inside the cover with large cross section or multi purpose channel will be constructed. By this action required adaptation with fault displacement will be done widely.

Based on experiences of retrofitting examples, following notes are suggested.

- Welded joint is more suitable than connected structure
- In case of pipeline crossing the definite fault, possibly it's better to perform above ground pipeline.
- In connection to tank or structure flexible structure will be used.
- Material resistant against impact and with appropriate lengthening
- Filling 15 cm restricted area around pipe with sand soil is very effective. (aimed to reduce soil clamp force)
- In fault crossing location, a large cover with diameter more than 5 cm should be installed by plastic separator
- Developing bending in pipe and further space toward ground deformation.
- Pipe installation depth is low

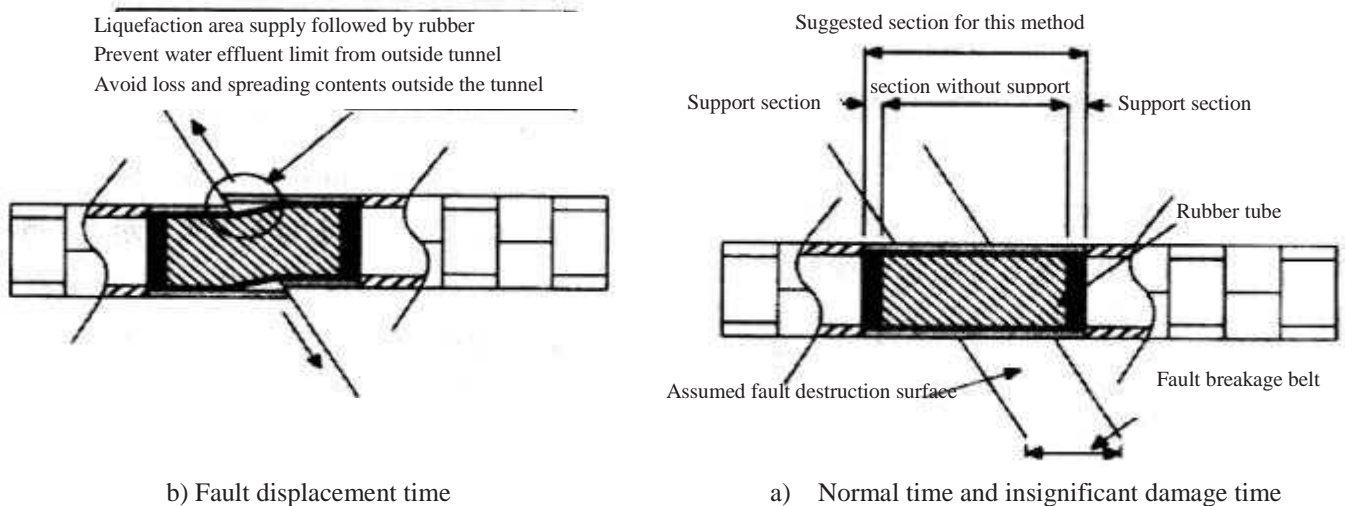

Figure 5-4- Countermeasures Against Fault Displacement Based on Inertia

5-2-3-2-2- Buried Pipeline Rehabilitation for the Other Failure Modes

Displacement control in liquefaction by combined pipe:

Outside part of concrete pipe is made as a box and arc shape and called combined pipe. Because this pipe is heavier than the other types, it prevents from raising and coming up when liquefaction occurs.

Joint will be combined by a metal with adjust slot. In the state of being pulled in the ground axis direction, adjust slot prevents emerging pipe by a metal brace.

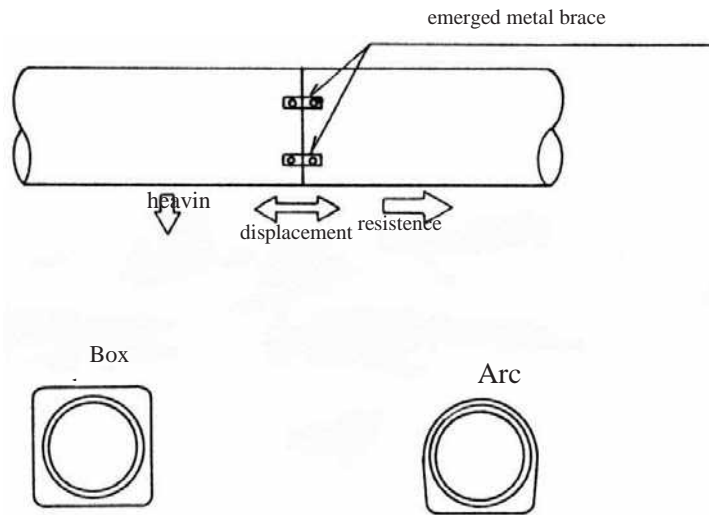
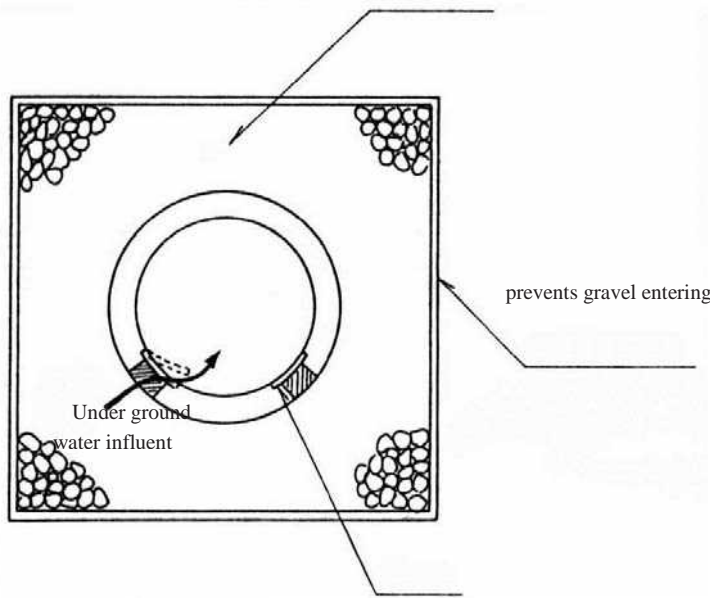

Figure 5-5- Displacement Control in Liquefaction by Combined Pipe

Peripheral pressure discharge by developing pores in the wall tube :

In concrete pipe a pressure sensitive hole for passing water will be considered. When earthquake occurs additional pressure of around water will be discharged inside through this hole. Around the pipe will be covered by soft handmade sand and one lining layer preventing soil and gravel entering inside. In this case sucker and protective taking out material prevents soil and gravel and sand entering.



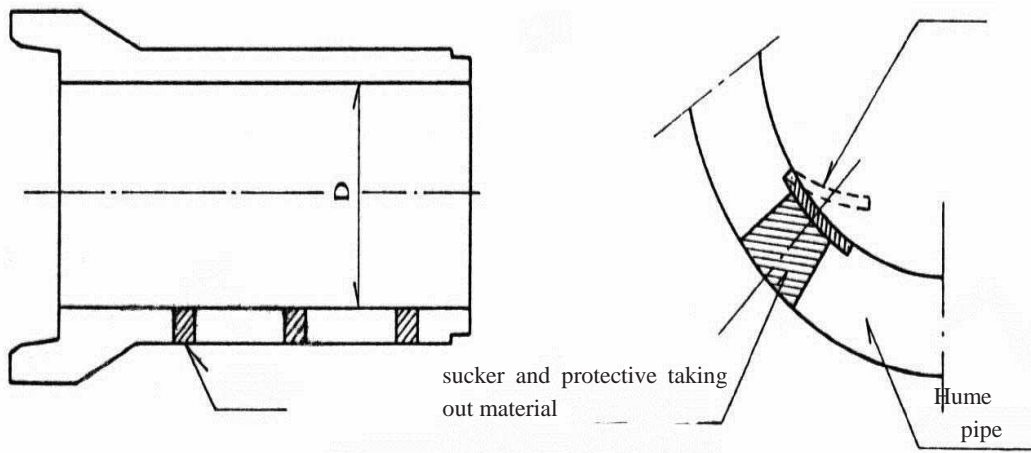

Figure 5-6- Peripheral Pressure Discharge by Developing Pores in the Wall Tube

Ground deformation control by flexible pipe:

A long plastic part is ribbed and bended and then is shaped as a pipe. This pipe is coordinated with internal ground motion and generally has an appropriate flexibility.

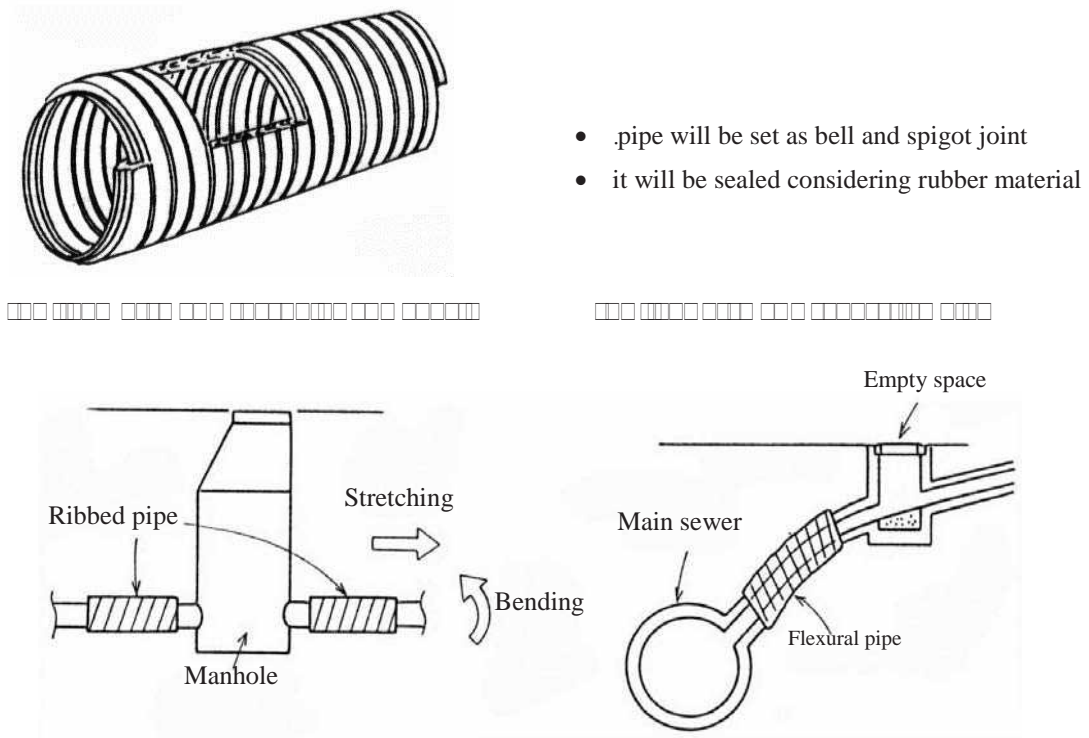
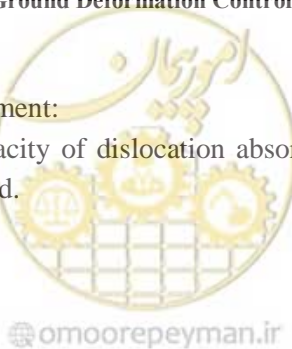

Figure 5-7- Ground Deformation Control by Flexible Pipe

Flexible joint to withstand displacement:

By expansion joint sufficient capacity of dislocation absorption is developed in the pipe and thus breakage in the tunnel will be prevented.



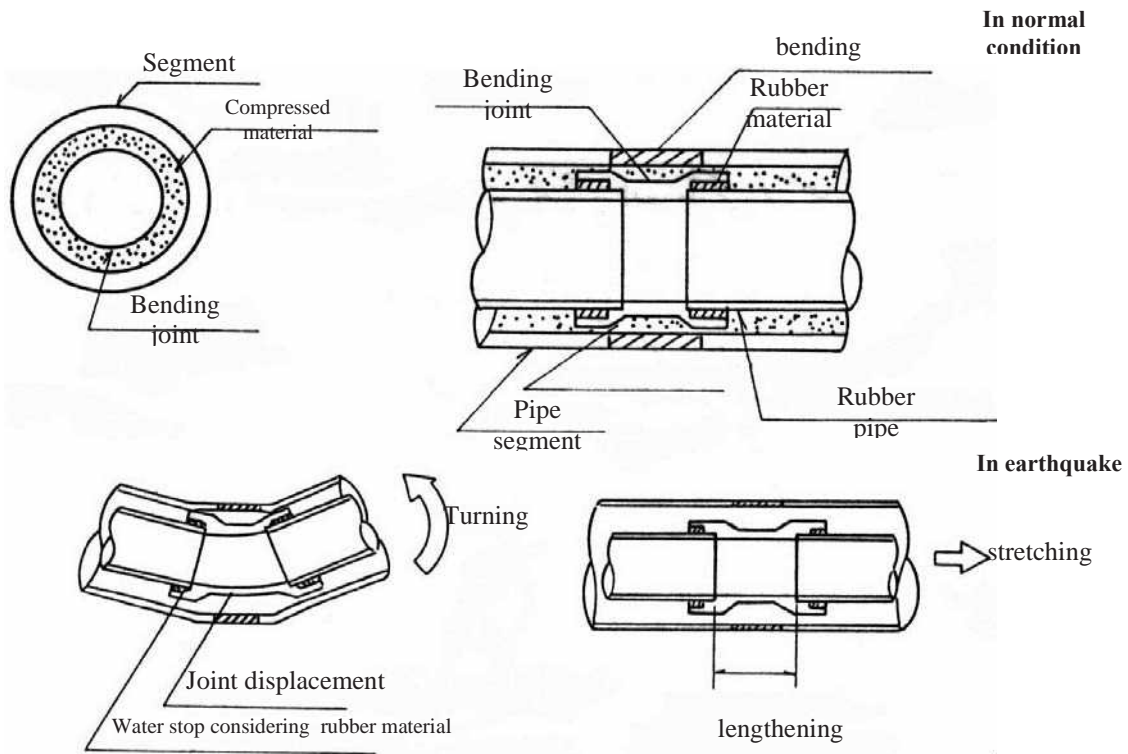

Figure 5-8- Flexible joint to withstand displacement

Bracing to develop longitudinal freedom:

Horizontal bracing coincident with displacement by brace bolt prevent pipe removal.



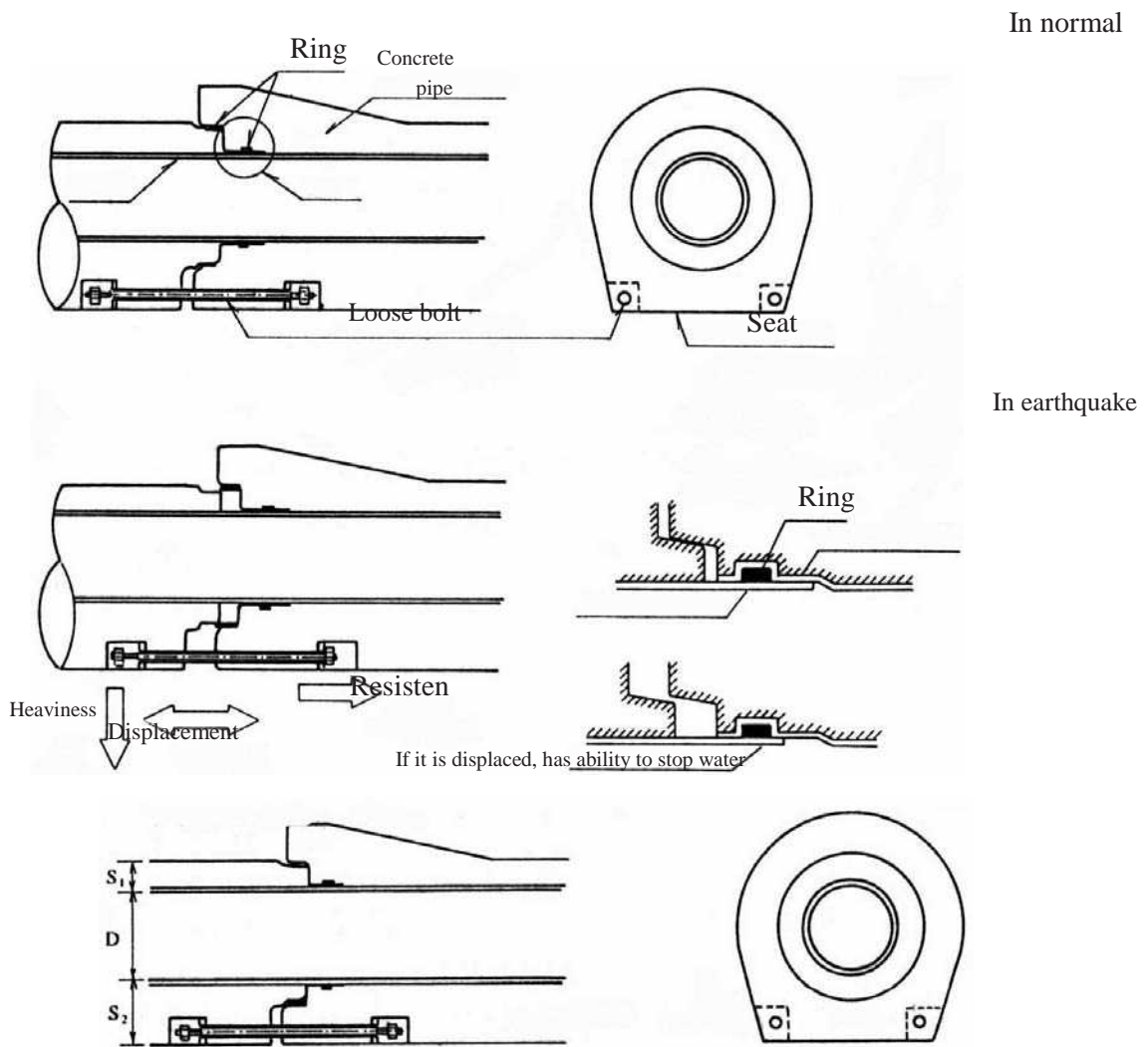

Figure 5-9- Bracing to Develop Longitudinal Freedom

Flexible ring joint: In pipe joint, a specified form of rubber ring is used and coincident with keeping water leakage and according to bending and displacement, it will prevent raising pipe in liquefaction.

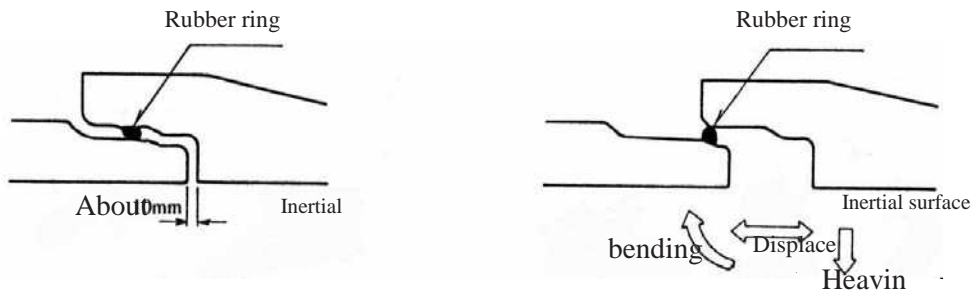

Figure 5-10- Flexible Ring Joint (In Earthquake and Normal Time)

Pre-stressed joint to prevent pipe removal:



Concrete pipe is doubled than before and two pipes are joined by compression ring and it will be prevented. Bell is amplified by a steel sheet and to withstand tension force inside the pipe pre-stressed steel will be used.

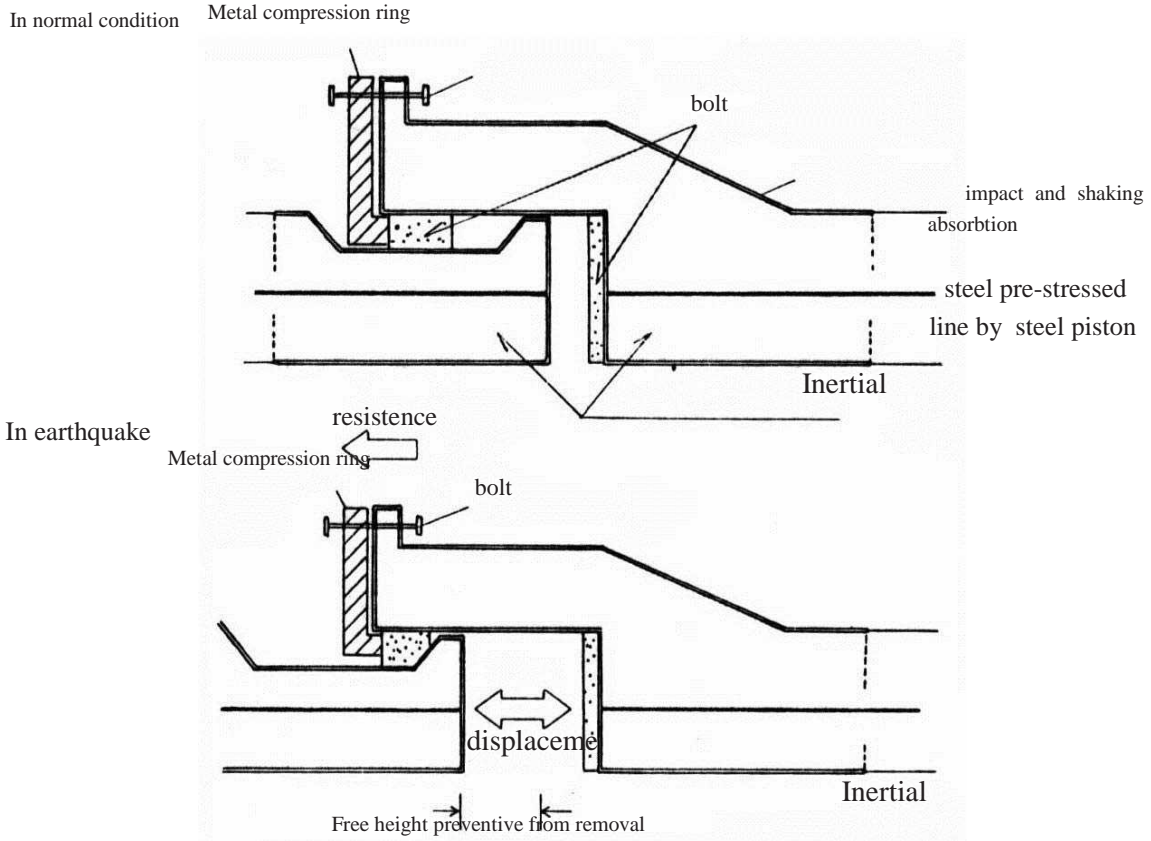
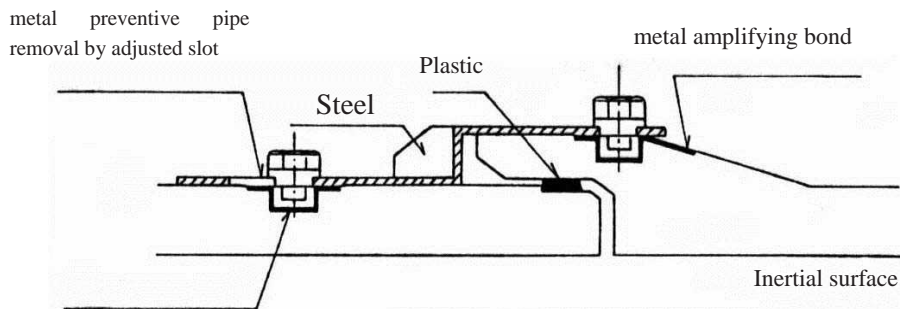

Figure 5-11- Pre-stressed Joint to Prevent Pipe Removal

Preventing joint removal by slotted metal segment:

In concrete pipe joints, metal segment is installed by adjusted slot and it will prevent joint removal.



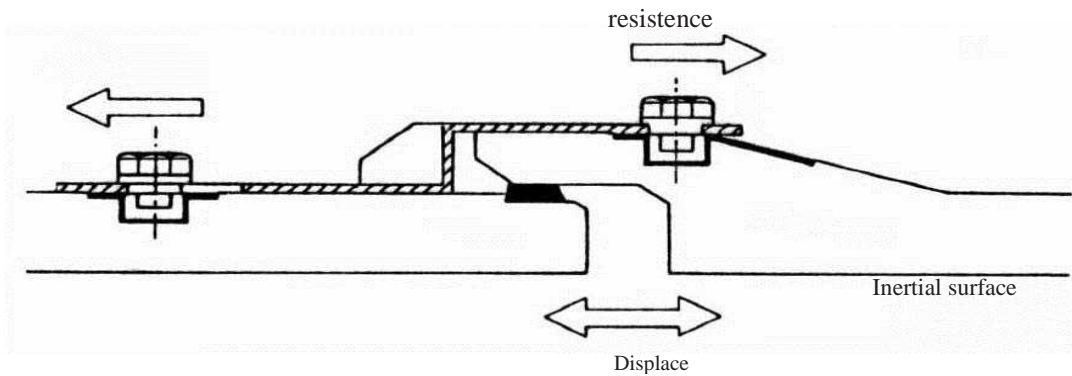

Figure 5-12- Prevent Joint Removal by Slotted Metal Segment

Braced joint:

Further to lengthening previous concrete pipe joint, rubber ring is used in joint section and to prevent pipe separation an obstacle will be installed.

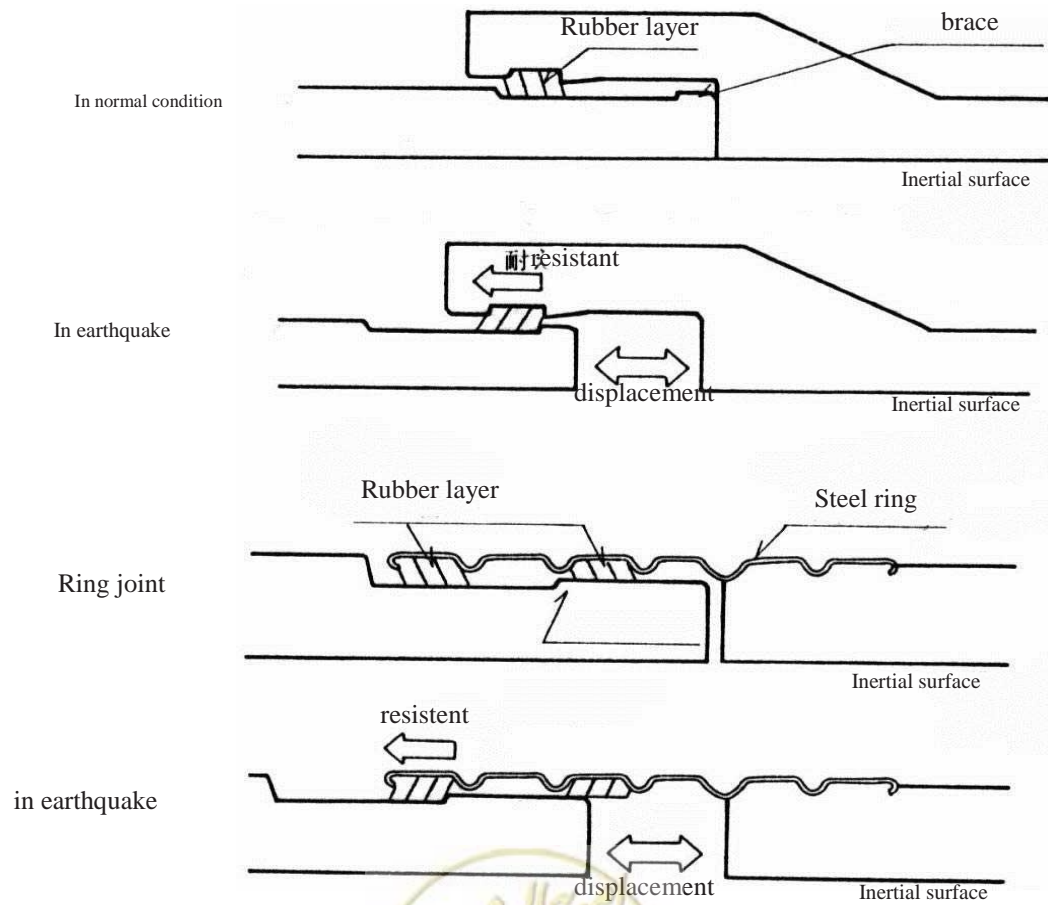
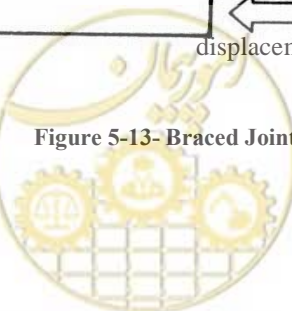

Figure 5-13- Braced Joint



Flexible joint by rubber wedge shaped ring: Rubber wedge shaped ring is compressed to a steel ring and prevents pipe removal. Furthermore, this ring prevents water leakage by increasing flexibility.

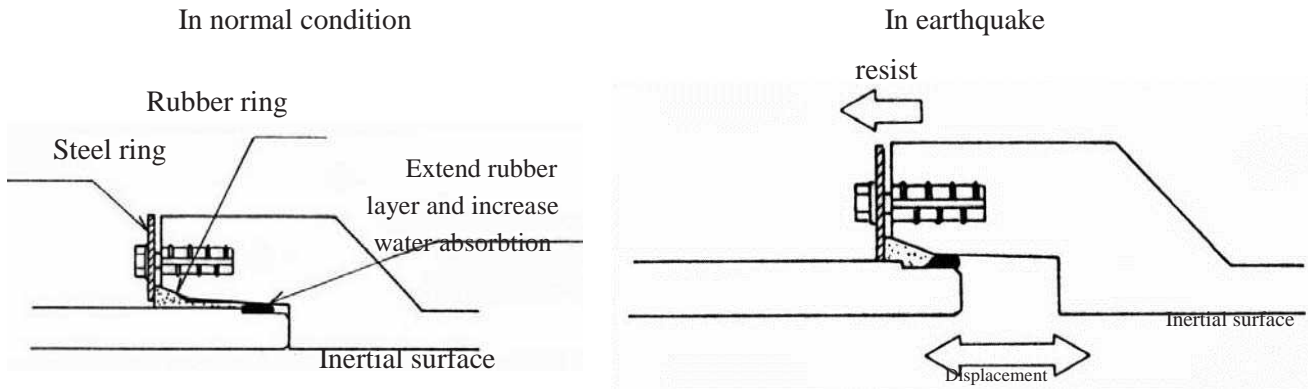

Figure 5-14- Flexible Joint by Rubber Wedge Shaped Ring

Joint by incidence preventive ring:

Considering details in figure 5-15, in this joint a rubber is used to sealing. To prevent separating both end of joint an outside sheet, which is connected to body pipe by bolt and nut, is used.

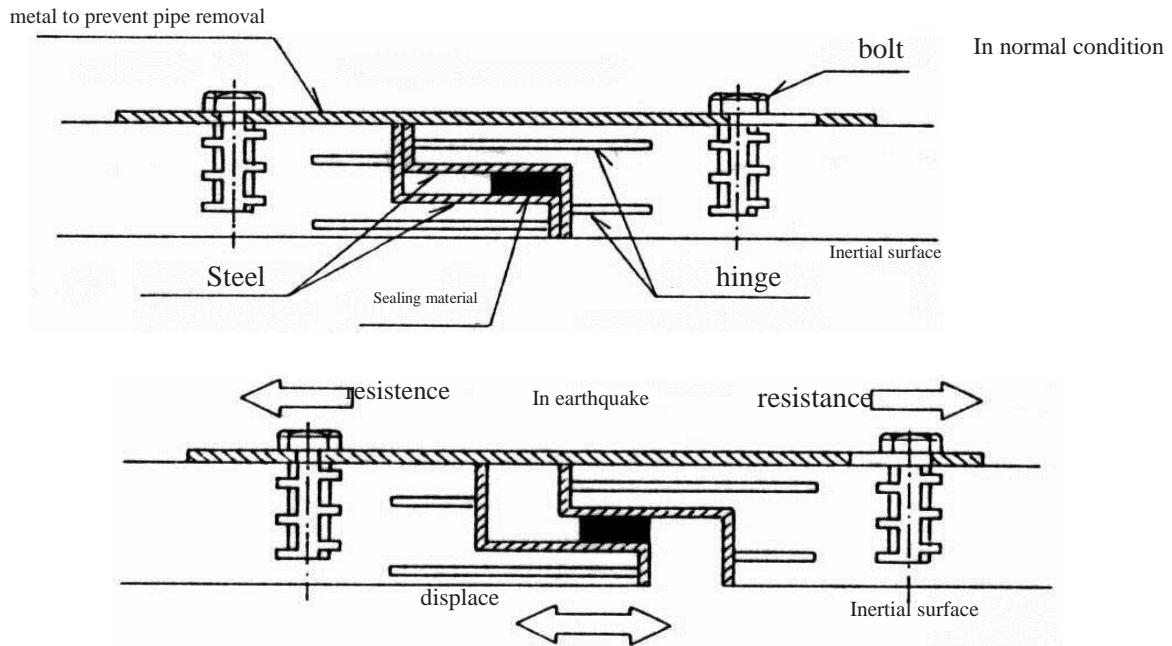

Figure 5-15- Joint by Incidence Preventive Ring

Flexible joint by large pillow:

In normal condition this joint is sealed by a rubber pillow as shown in detail in figure 5-16 in earthquake, polyethylene and polyurethane rings prevent pipe removal in joints and water leakage.



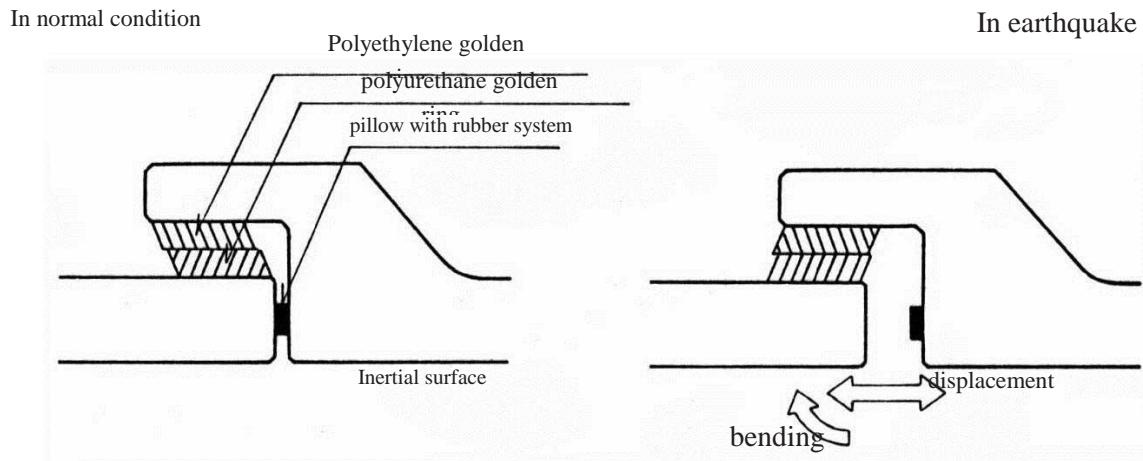

Figure 5-16- Flexible Joint by Large Pillow

Plastic safeguard joint:

Pillow and plastic ring are used in joint section and by using flexible polypropylene safeguard pipe removal is prevented.

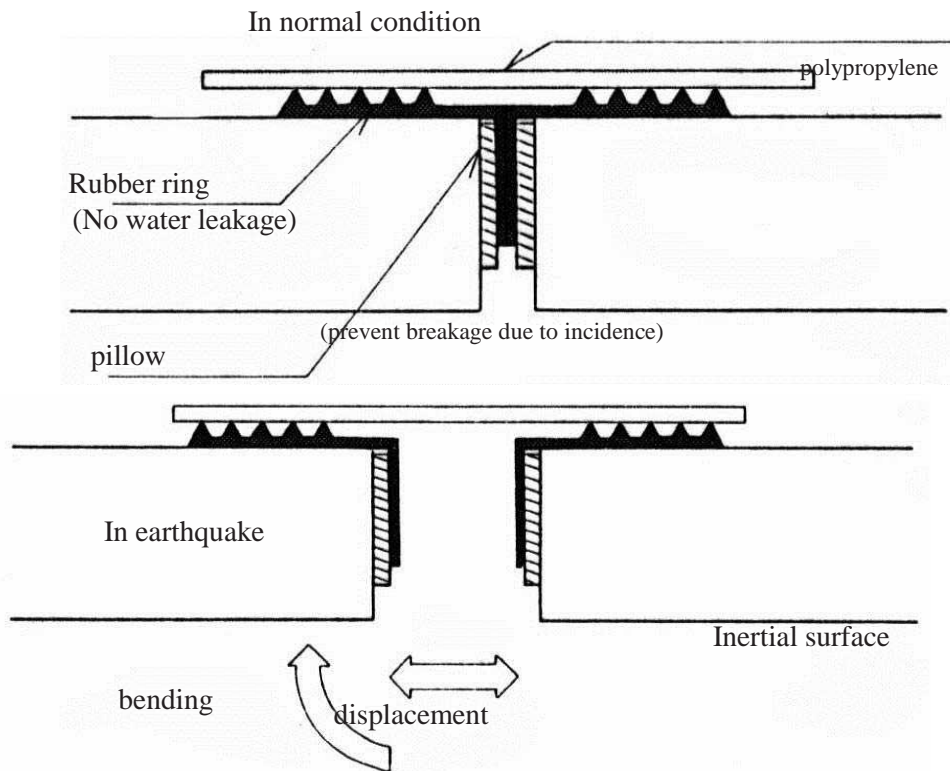
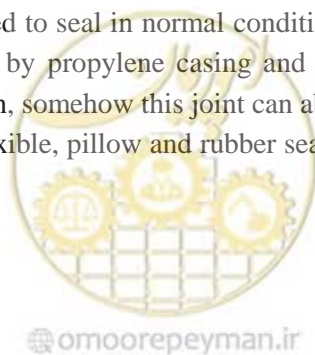

Figure 5-17- Plastic Safeguard Joint

Rubber ring safeguard joint:

In this joint a rubber pillow is used to seal in normal condition. In earthquake which two pipe ends in joint moves away and near, sealing by propylene casing and rubber ring is provided. Further to axial expansion and constriction absorbtion, somehow this joint can absorb rotation due to bending.

In plastic obstruction which is flexible, pillow and rubber sealed ring is sticked and thus it will be able to bend and displace.



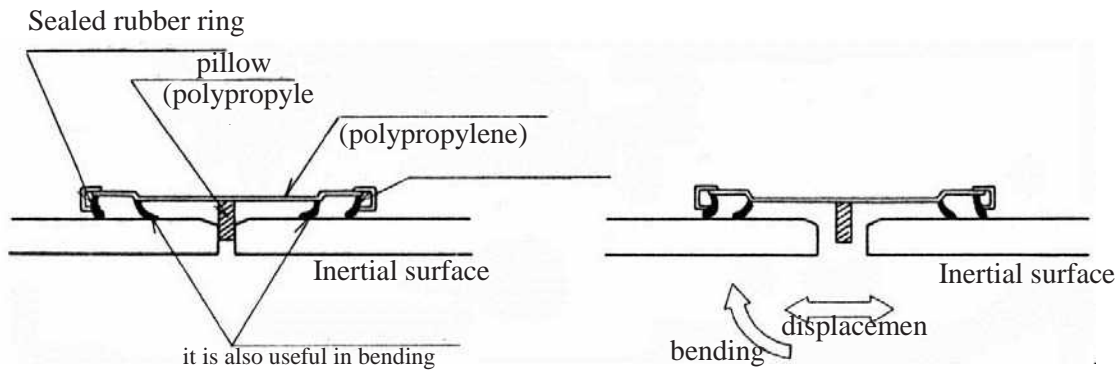

Figure 5-18- Rubber Ring Safeguard Joint

Chain joint pipe:

Concrete pipe segments are joined by chain and to a certain extent which pipe does not break, the pipe will be correspond to displacement and bending. Chain is connected in 3 to 5 portion of concrete pipe with sufficient height.

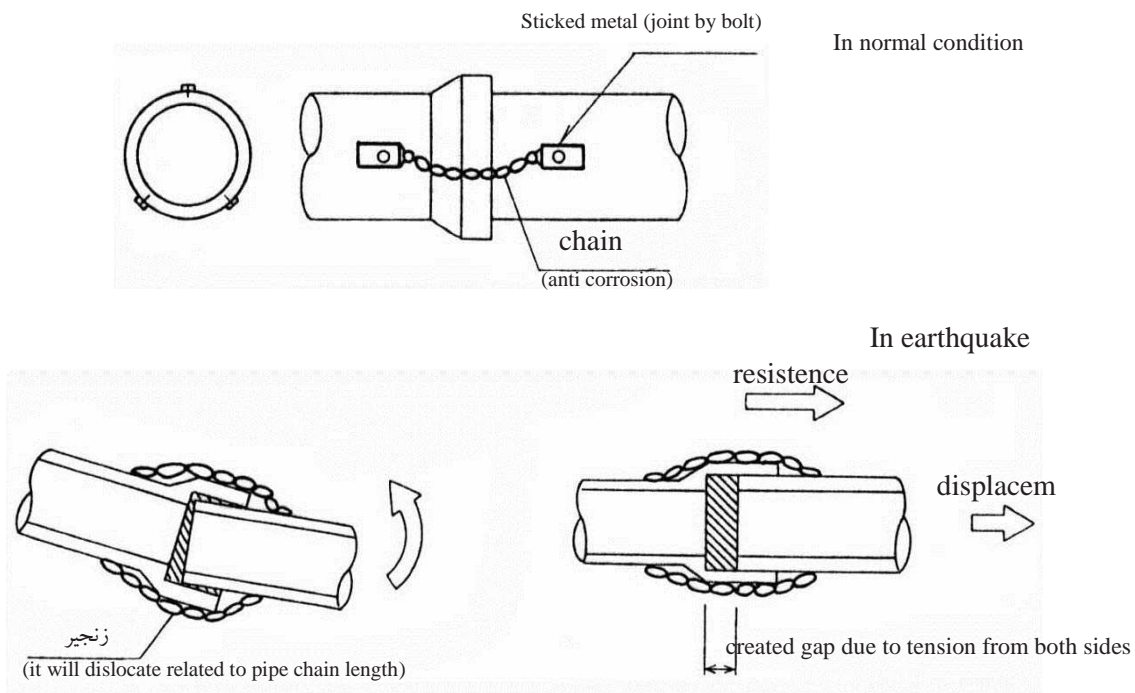

Figure 5-19- Chain Joint Pipe

T shaped rubber safeguard joint:

By a full rubber casing, which in the middle has a connected rubber gasket (a section is observed as a T) the function is as followings:

This casing seals the joint for its lifetime in both normal condition and in earthquake.

Additional gasket inside casing prevents pipe end crushing in collision.

Using two strap or steel bonds in both sides of casing prevents pipe removal or water leakage.

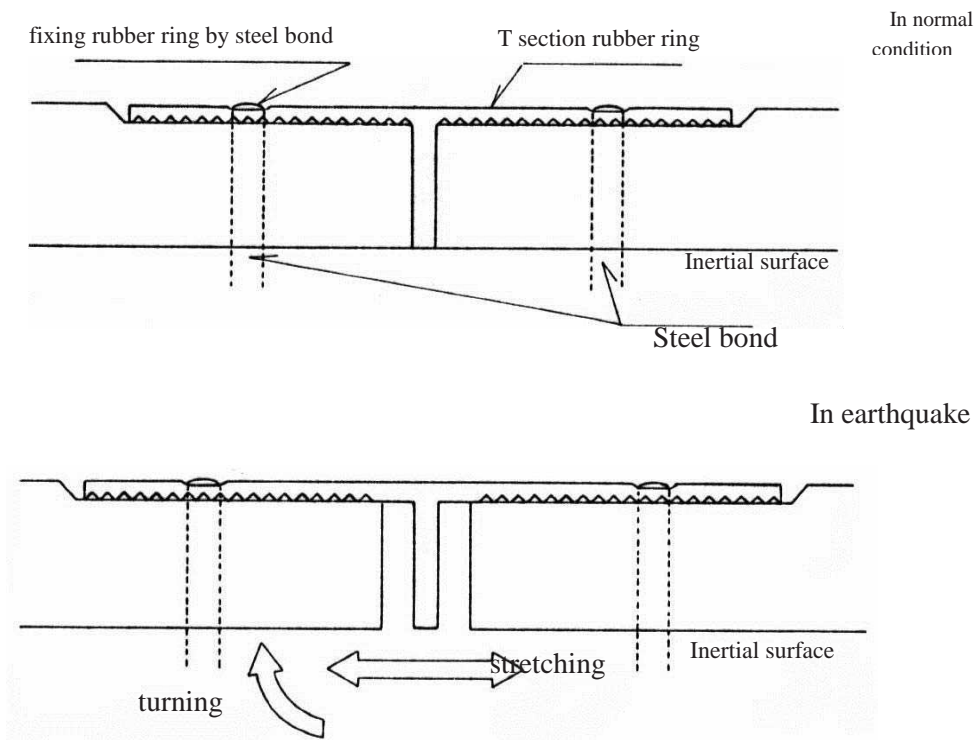

Figure 5-20- T Shaped Rubber Safeguard Joint

Steel safeguard joint:

In this joint rubber ring is stretched and guarded by a steel safeguard. Details are shown in figure 5-21.

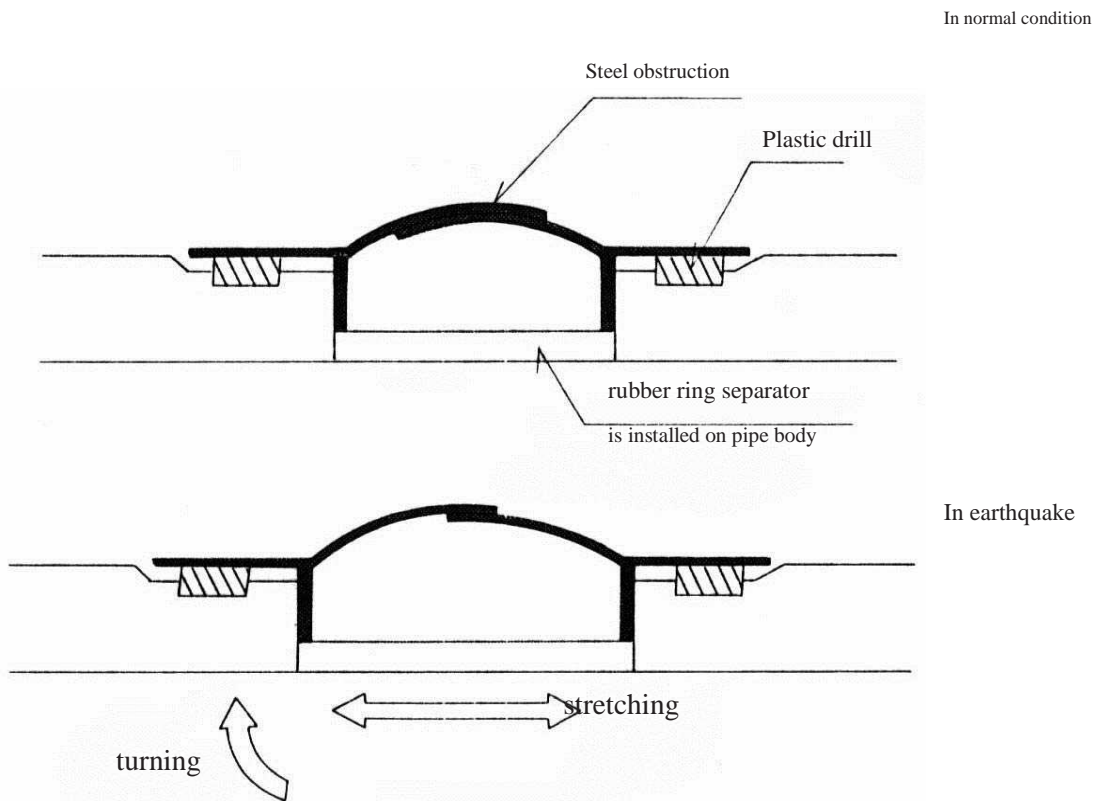

Figure 5-21- Steel Safeguard Joint

Flexible screw spring joint:

In this joint screw prevents removal of both end of pipe in the joint and spring between fin and nut gives flexibility to the joint.

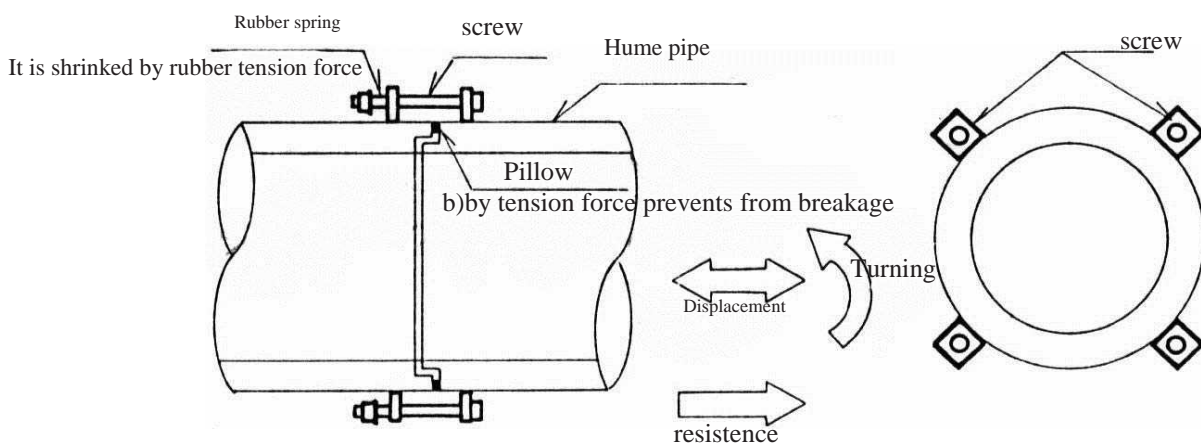

Figure 5-22- Flexible Screw Spring Joint

Box flexible joint:

In this joint sealing and flexibility is provided by a soft rubber between two ends and pipe removal preventive metal.



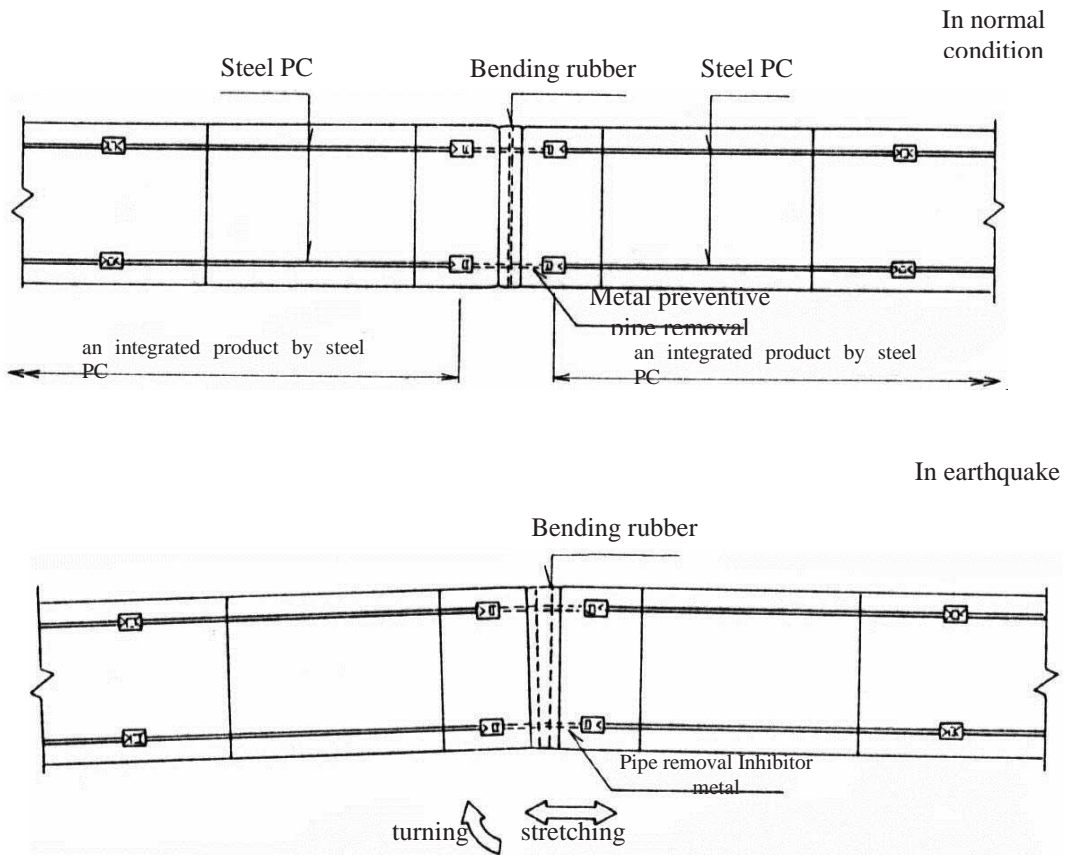
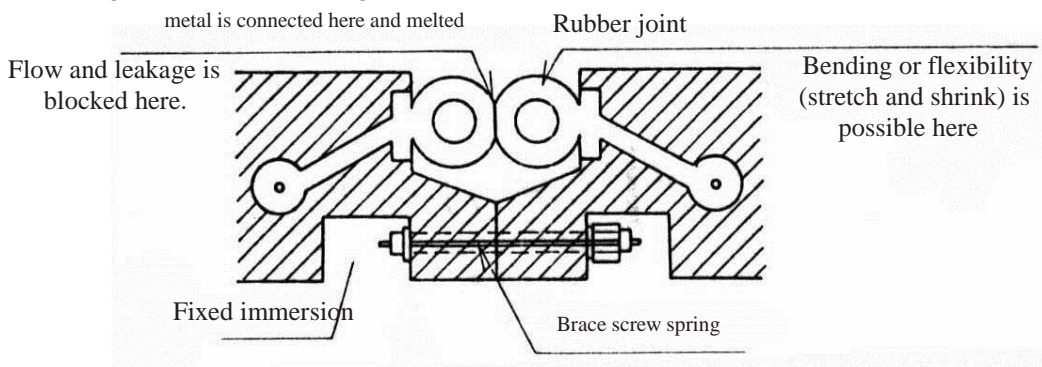

Figure 5-23- Box Flexible Joint

Rubber joint:

In joint section, pipe segments of a flexible joint with a specific rubber compound as original material will be connected by a rubber brace screw spring. The segments when stretching or contraction have high power in blocking flow or water leakage.



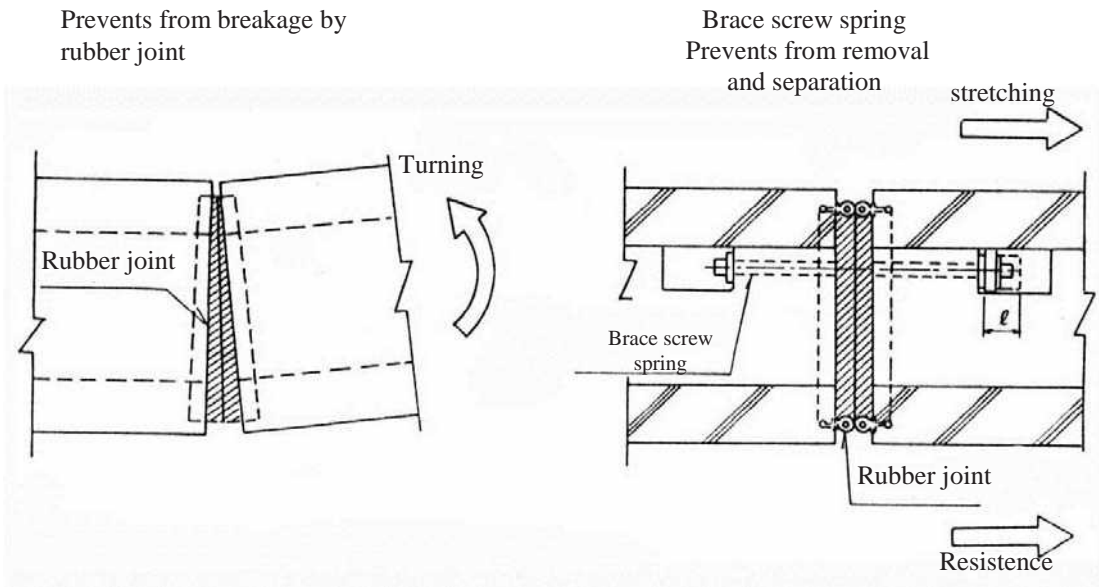
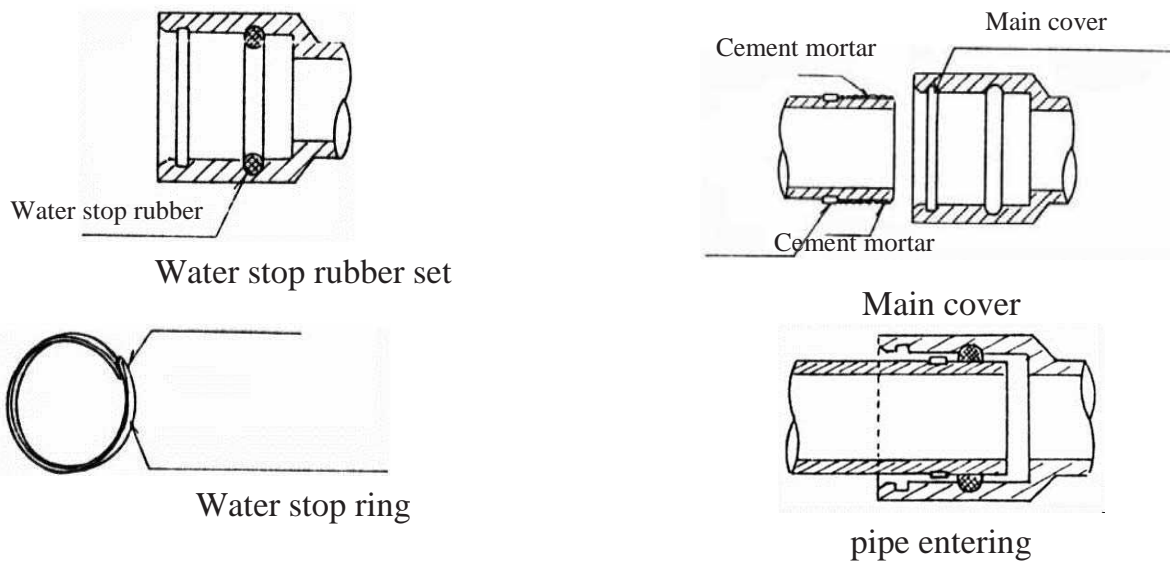

Figure 5-24- Rubber Joint

Bell and spigot joint: An obstacle is added to rubber ring joint of plastic pipe and prevents pipe removal. Inlet obstacle is installed when producing and after the pipe enters, lock ring is added to it and to prevent lock ring removal, receiver part of pipe head will be heated in location.



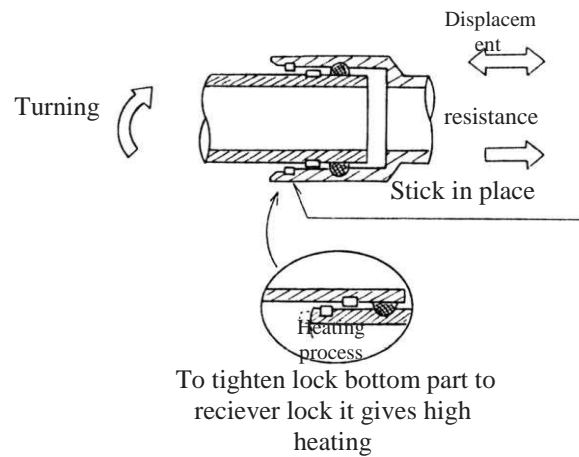

Figure 5-25- Bell and Spigot Joint

Long bell and spigot joint:

By increasing overlapping length in bell and spigot joint joint behavior will be integrated and capacity of force and displacement absorption will be increased.

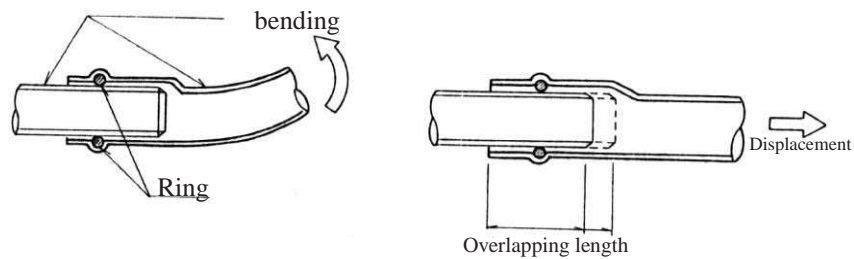

Figure 5-26- Long Bell and Spigot Joint



Flange joint with freedom:

In combined reinforced pipe joint flange and dent is added. This joint coincident with displacement and bending and turning prevents pipe removal. Also, this joint has a little freedom and will be installed as a segment.

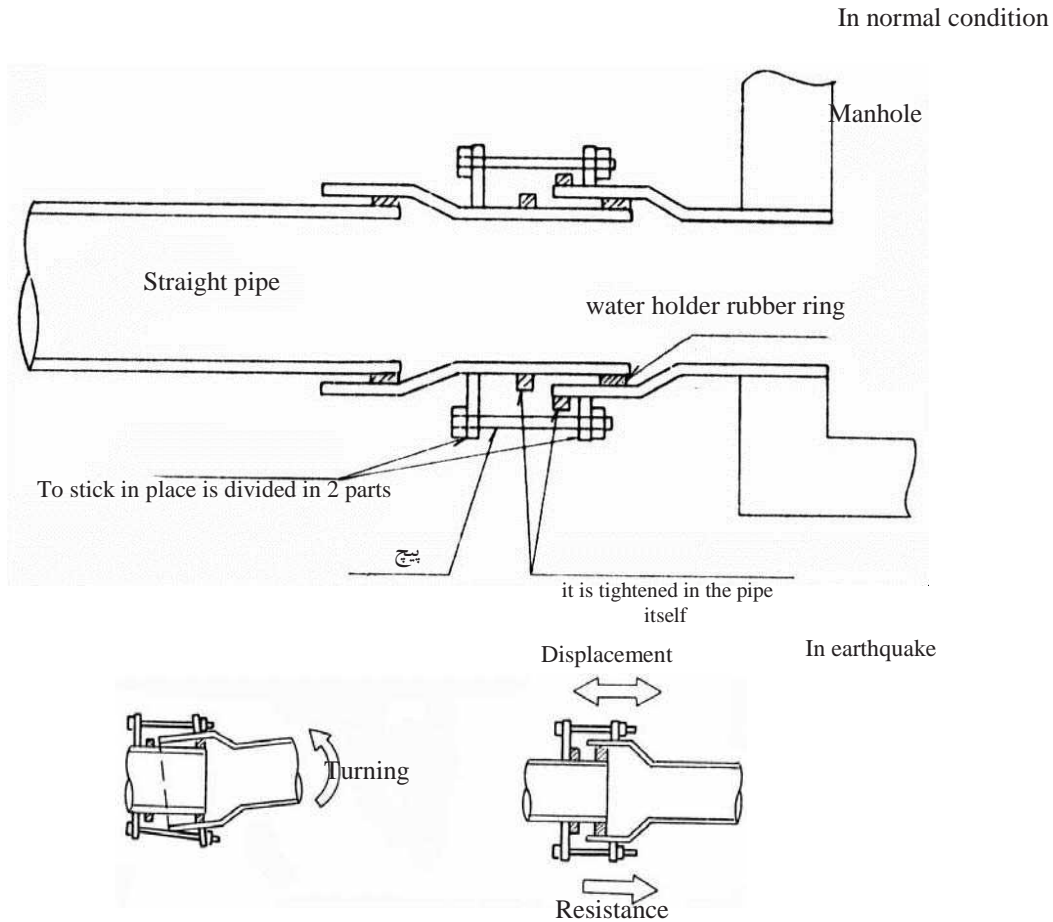

Figure 5-27- Flange joint with freedom

Inertial long flexible coating:

Installing inertial long flexible coating, further to creating flexibility in pipe, it will improve waterproofing.



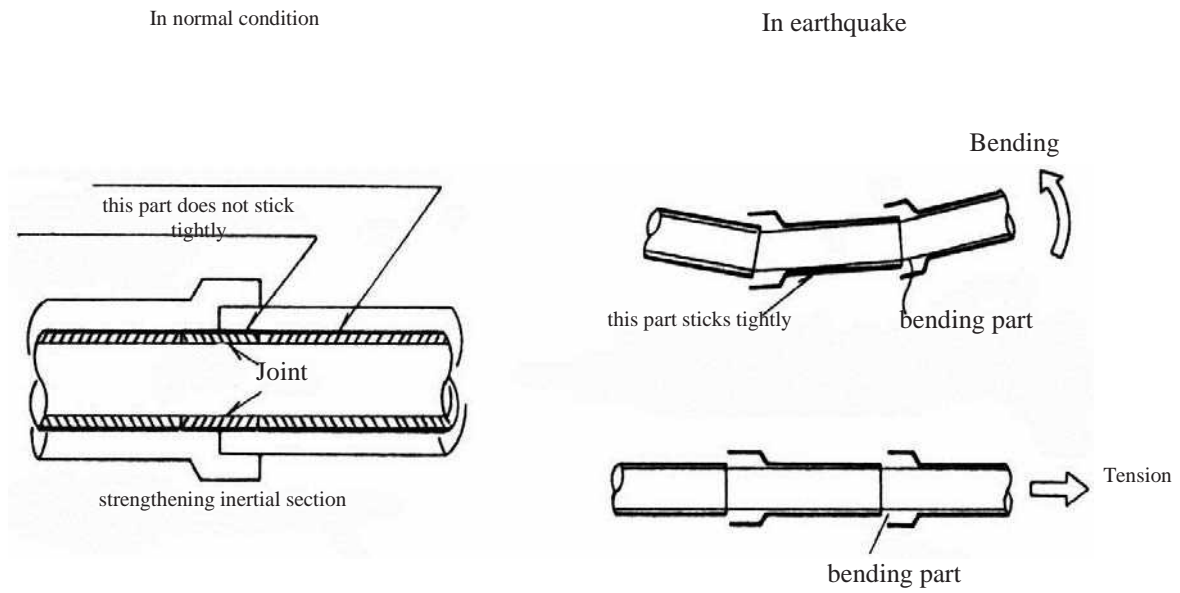

Figure 5-28- Inertial Long Flexible Coating

Ductile cast iron pipe joint:

In cast iron pipes seismic joints are generally similar to figure 5-29 in this joint collision and removal is prevented further to sealing by rubber ring two fin and groove are used to anchor spigot pipe end.

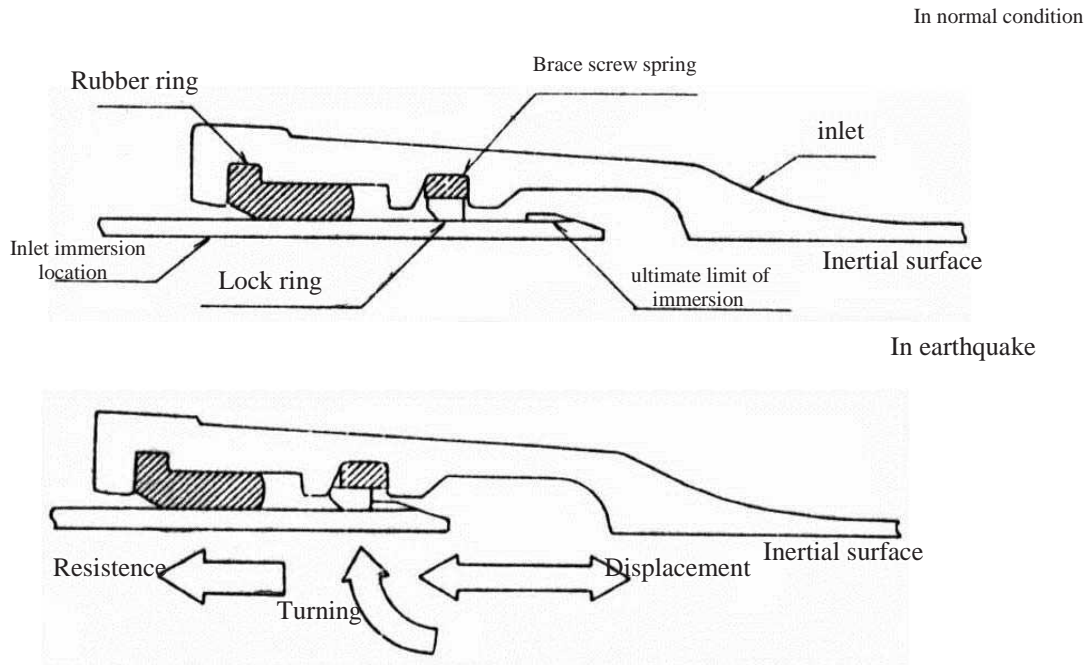

Figure 5-29- Ductile Cast Iron Pipe Joint



5-2-3-3- Manhole, Concrete Conduit, Shield Tunnel and Access Routes

5-2-3-3-1- Seismic Failure Modes

Failure modes in manholes such as body failures, joint to pipe damages, displacement and general instability. Stiffness and behavior change in joint to pipe location cause weakness in earthquake and an appropriate measure should be done for retrofitting. Access routes have similar failure modes which is given in the tables below.

Table 5-4- Failure Modes in Access Routes

Failure Modes	Rate		Important condition of ground surface site
	High	Low	
Hole failure	Split, cover displacement, cover frame failure, body failure		Soft and slack soils, house construction soils and easily liquefied soils
Connection pipe failure	Emerging and corrosion, pipe body and hole failure		

Table 5-5- Failure Modes in Manhole

Failure Mode	Rate (Limit)		Important condition of ground surface site
	High	Low	
Failure in joints between bricks and joint sections	Displacement and split, displacement in failure		Soft and weak soils, housing construction soils, easily liquefied soil, soil condition change in depth direction
Failure in straight and shrewd walls	failure between joints Joint split split in axis line Vertical direction		
	Crack Failure (circular, vertical direction)		
failure in wall establishment	Crack Failure		
lower sheet failure	Crack Failure		
Reverse failure	Crack Failure		
Body pipe raising and surrounding soil settling	Surrounding soil settling, body raising (Just in liquefaction)		Soft surrounding soil settling, raising (surrounding soil settling)

Failure mode in manhole is illustrated as a model in figure 5-30 considering pipe safeguard installation, because lots of them are installed in depth of the earth, it is assumed that pipes will not be damaged. But frequently cracks in bricks inside the pipe and split and gap are observed. In places where

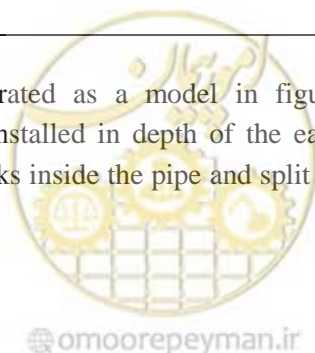

soil condition has changed suddenly in vertical direction, there is probability of failure in safeguarded manhole and pipe through joint section.

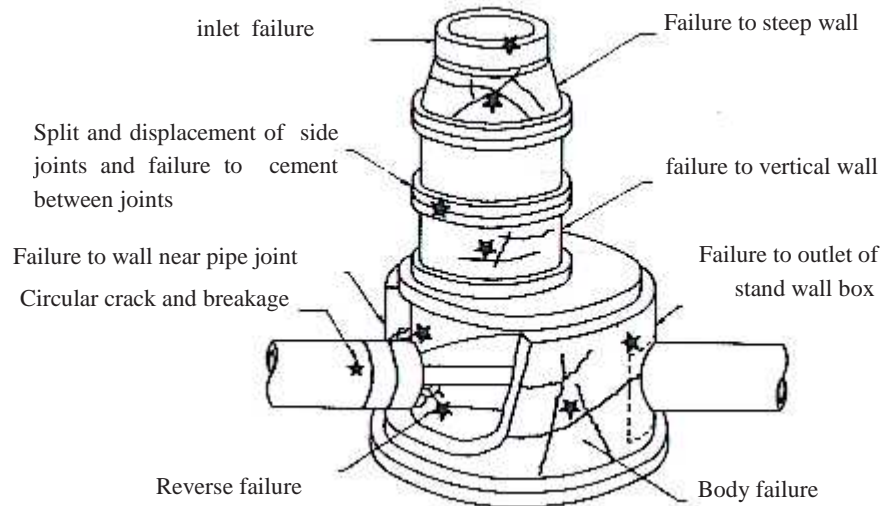

Figure 5-30- Various Failure Modes in Manhole

Failure modes in manhole can be summarized as following:

- Breakage
- Split or crack (in vertical wall and steep wall)
- Settlement (manhole vertical wall)
- Breakage, water leakage, emerging (for lower sheet of manhole)

5-2-3-3-2- Retrofitting Manhole for Every Failure Mode

(1) Bouyancy preventive grab:

In this method pipe and manhole are maintained by anchored grab in depth inside the soil and it will prevent from coming out.



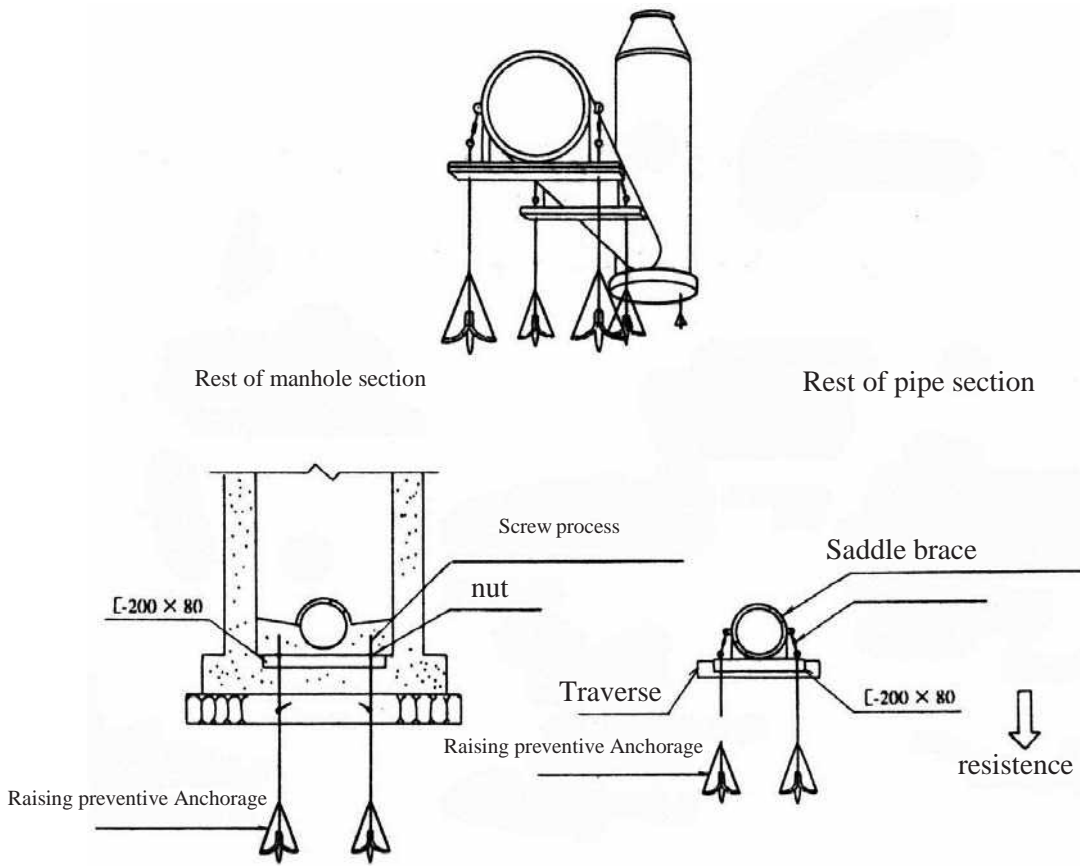
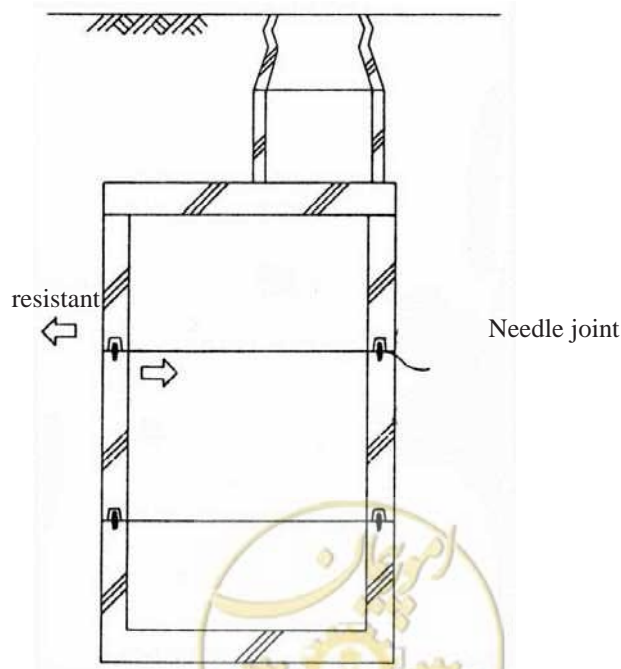

Figure 5-31- Buoyancy Preventive Grab

(2) Box shaped manhole:

It is used to prevent displacement from needle anchorage, to prevent water flow from box shaped manhole, and to close pores by insulation material.



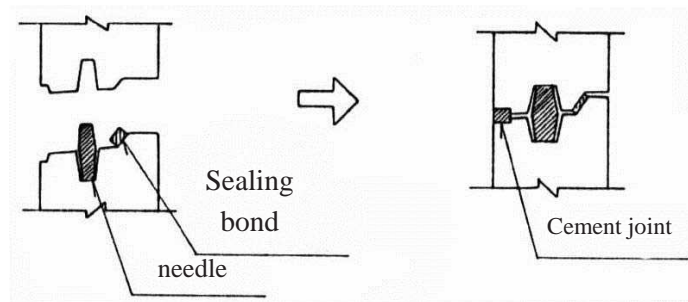

Figure 5-32- Box Shaped Manhole

(3) Plastic manhole:

Polyethylene manhole which has flexibility and moves according to ground surface motion and its displacement. In the same way flexible manhole joint with pipe segment makes it as an integrated structure which is adopted by pipe and manhole displacement when earthquake occurs.

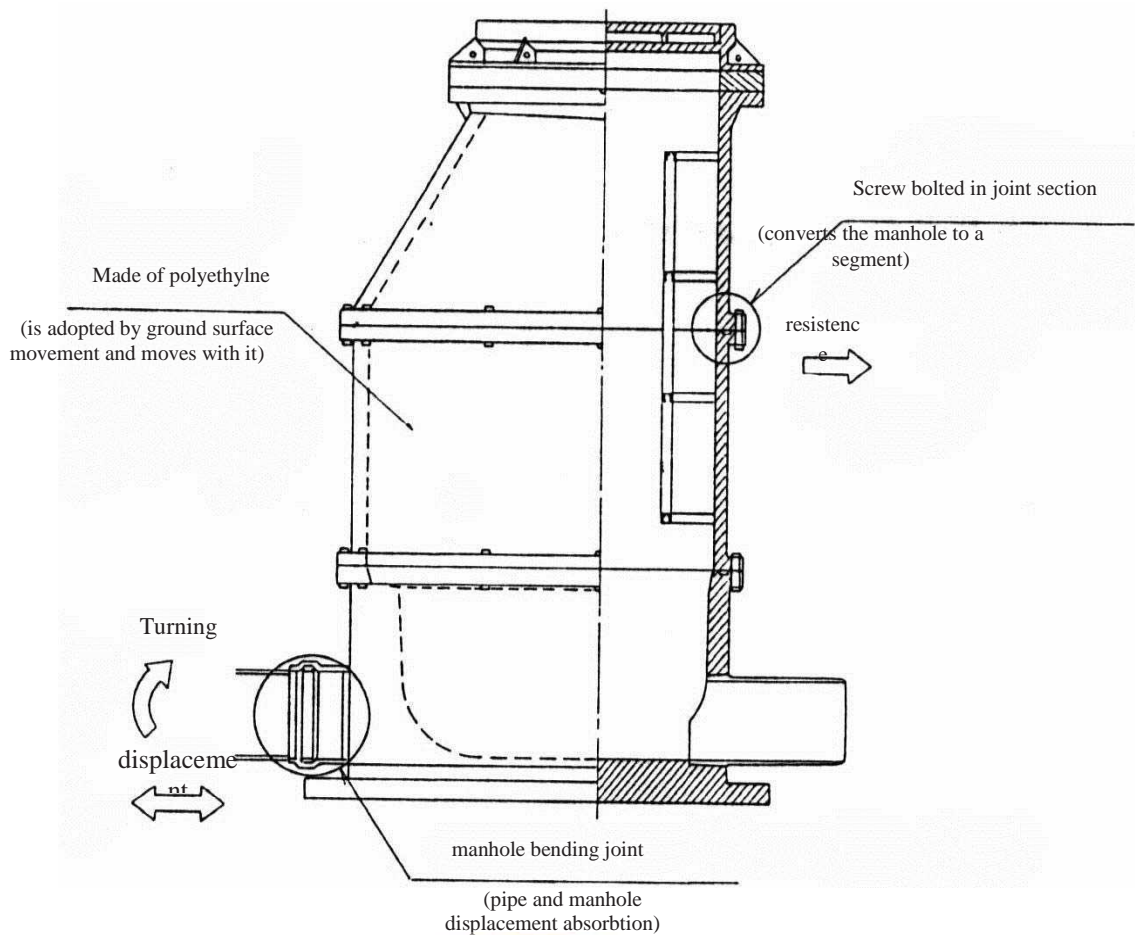

Figure 5-33- Plastic Manhole



(1) Plastic manhole with furnace slag:

By pozolane slag cement a high resistant manhole is constructed and in pipe and manhole connection a flexible material is used.

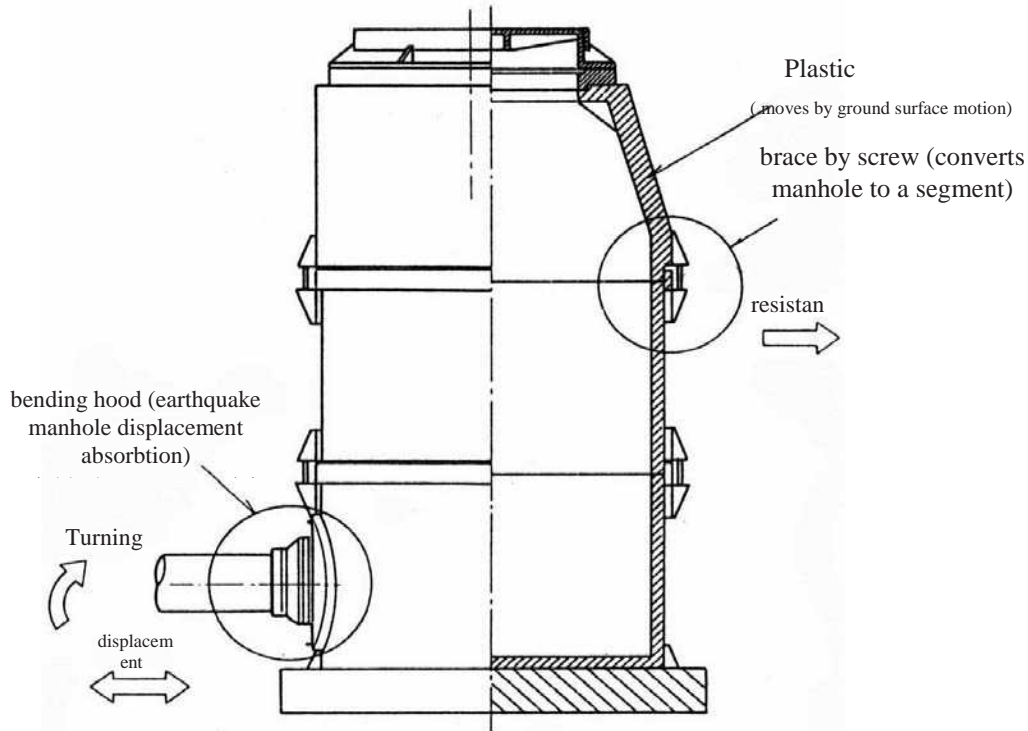

Figure 5-34- Plastic Manhole with Furnace Slag (Concrete)

(2) Reverse T shaped manhole:

Manhole and pipe are connected together and are made as an integrated T shape, and so manhole will be safe from damage, breakage, and joint removal.



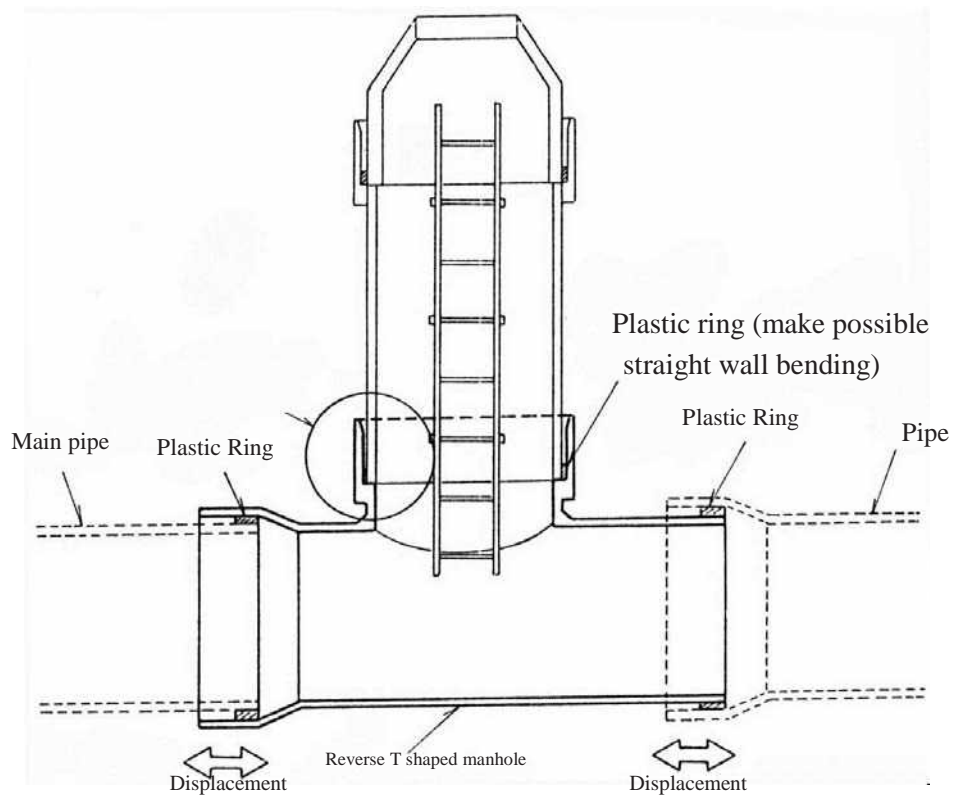

Figure 5-35- Reverse T Shaped Manhole

(3) Manhole Coating:

In manhole and joint connection a medium material is added, then a rubber resin with identical thickness is sprayed on these parts and all the manhole body is coated by a coating like a curtain.

(Prevent from decay)

Resin spray

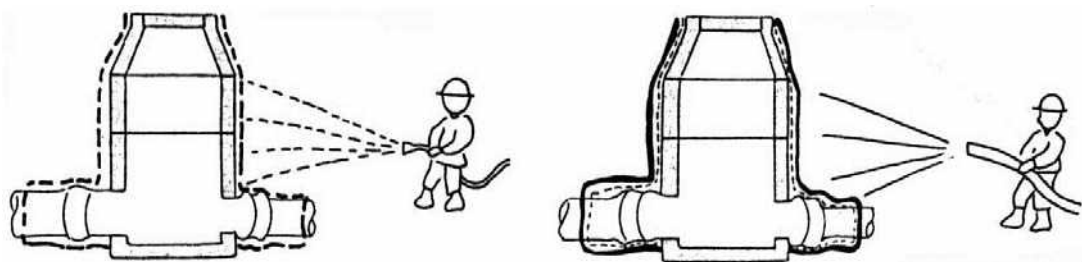

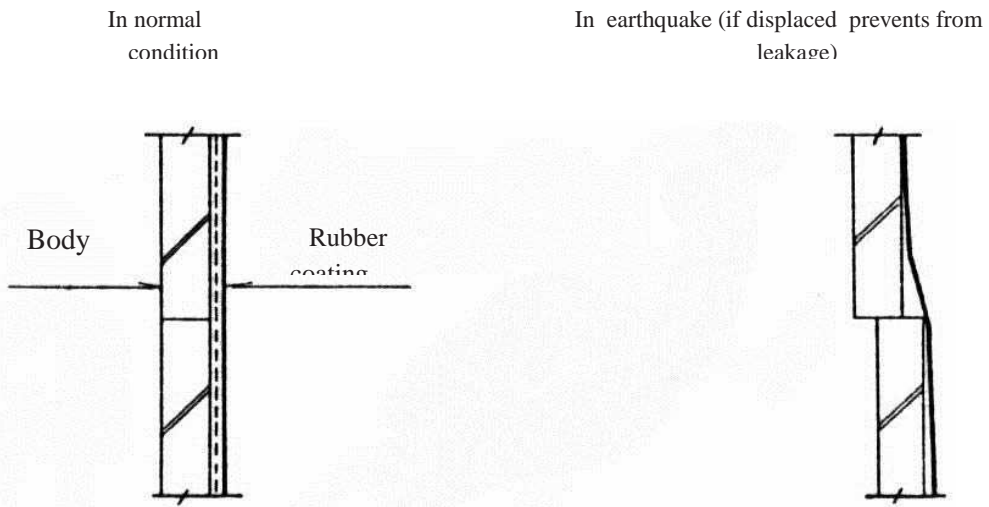

Figure 5-36- Manhole Coating

(4) Manhole resistant to bouyancy:

A hole for passing water in main body of manhole is created to discharge additional water pressure in pores when earthquake occurs. Around the manhole is filled by gravel and drainage material which water is passed through them.

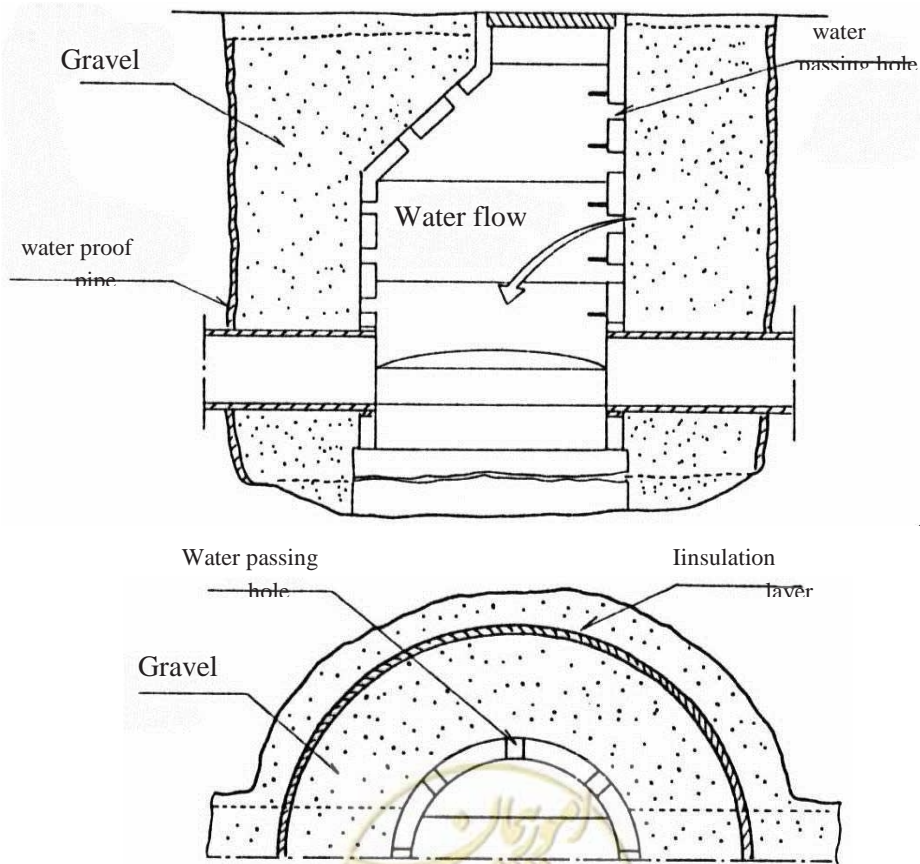

Figure 5-37- Manhole Resistant to Bouyancy

(5) Manhole resistant to displacement:

By a joint bar installation in contact place of two precast manhole segments, the capacity will increase against displacement and develop an integrated and resistant structure in ground motion.

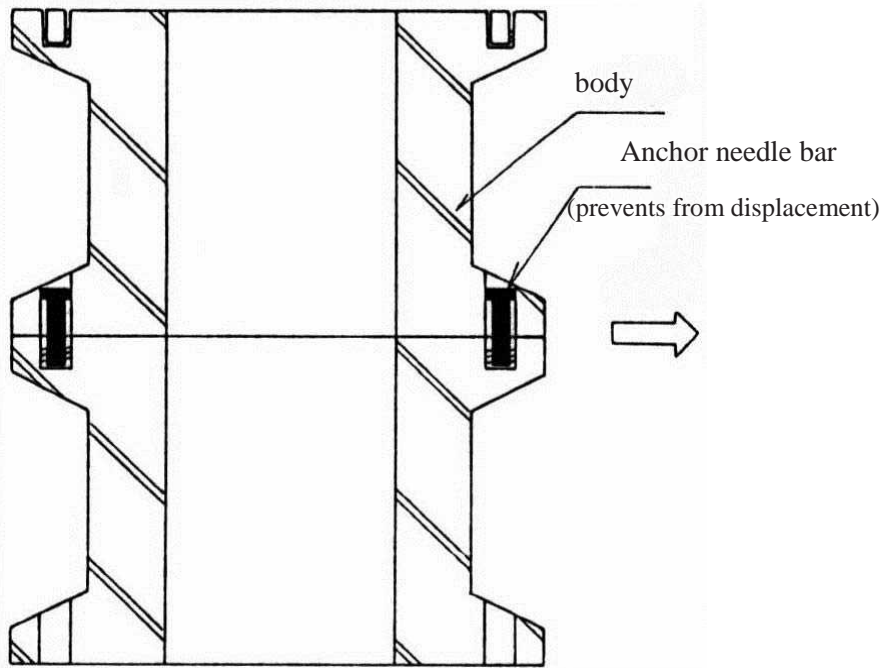
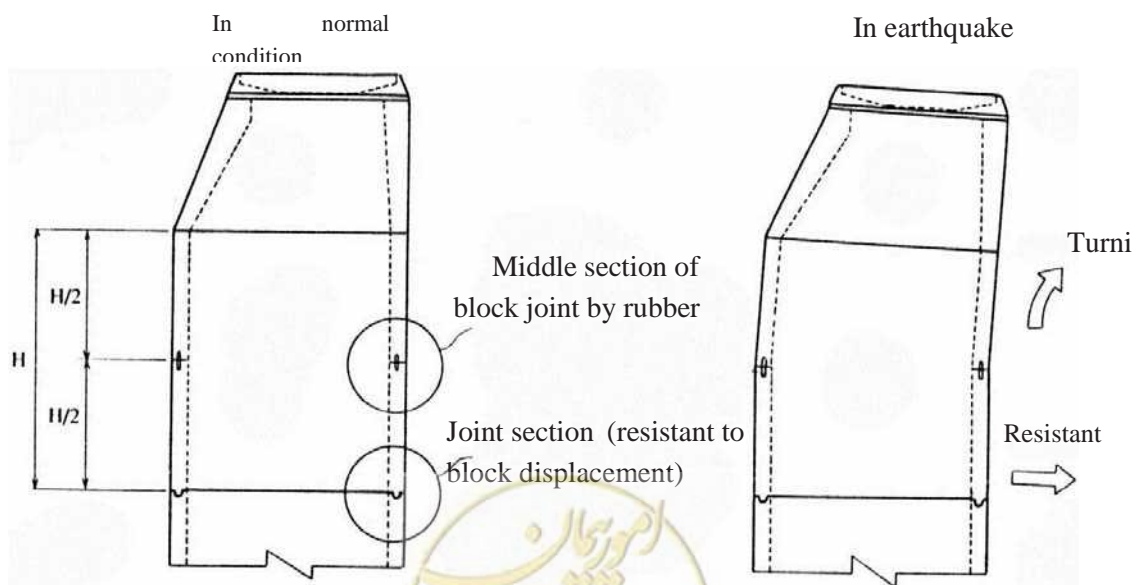

Figure 5-38- Manhole Resistant to Displacement

(6) Flexible Manhole:

A rubber joint is developed between combined block of manhole, and the flexibility of manhole will be increased.



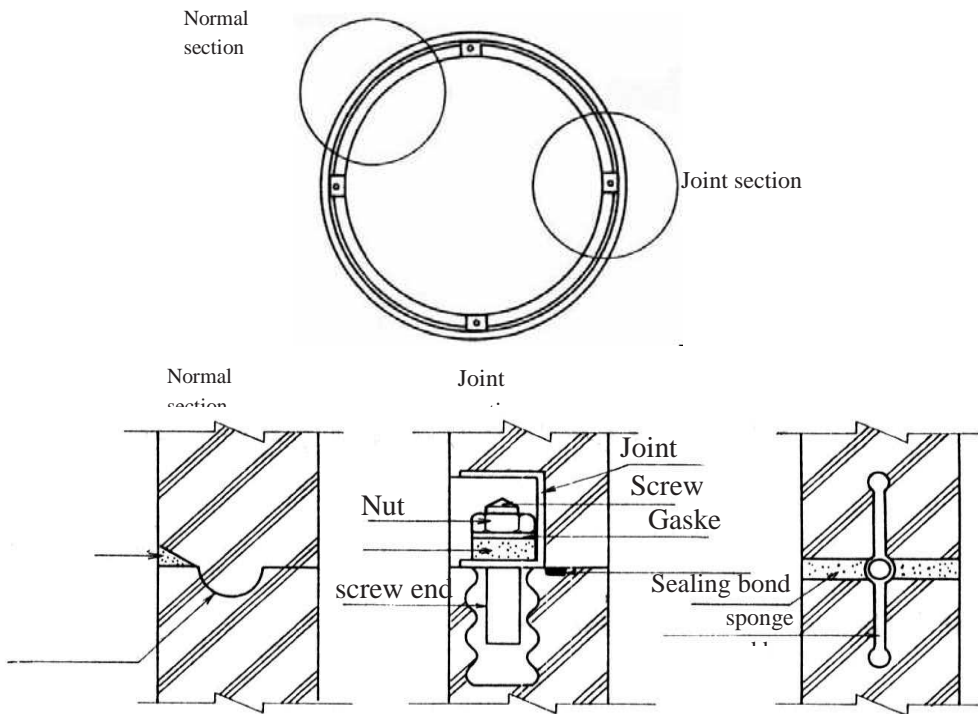

Figure 5-39- Flexible Manhole

(7) Braked flexible manhole joint:

An obstacle is installed in main body of manhole and it prevents pipe removal from manhole. 5 centimeters distance is considered between two obstacles and to prevent breakage in pipe due to pressure in manhole side, a pillow is used.

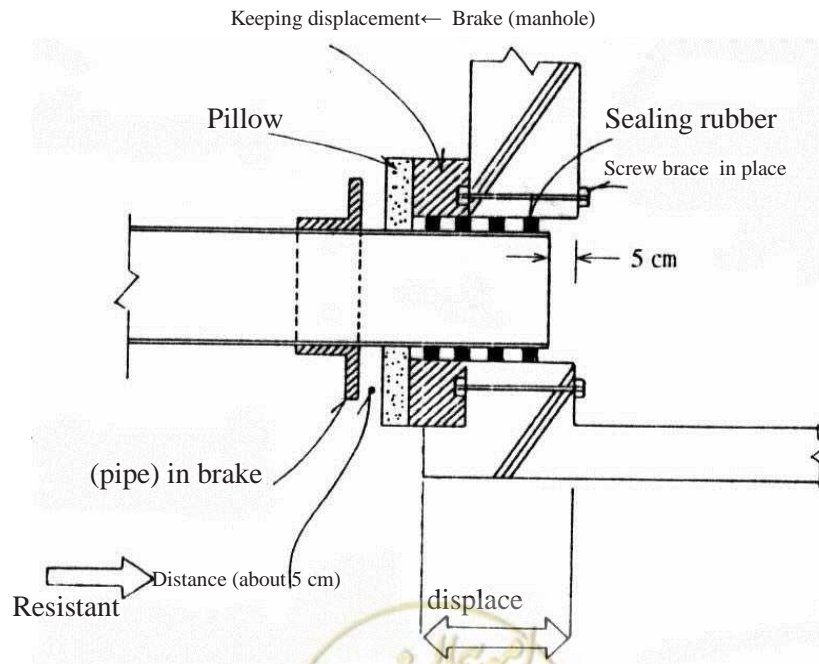

Figure 5-40- Braked Flexible Manhole Joint

(8) Short shield concrete pipe :

By joining flange to bottom of concrete pipe, at the same time, a shield flexible joint will be installed in place where pipe enters to manhole, contact part of pipe and manhole.

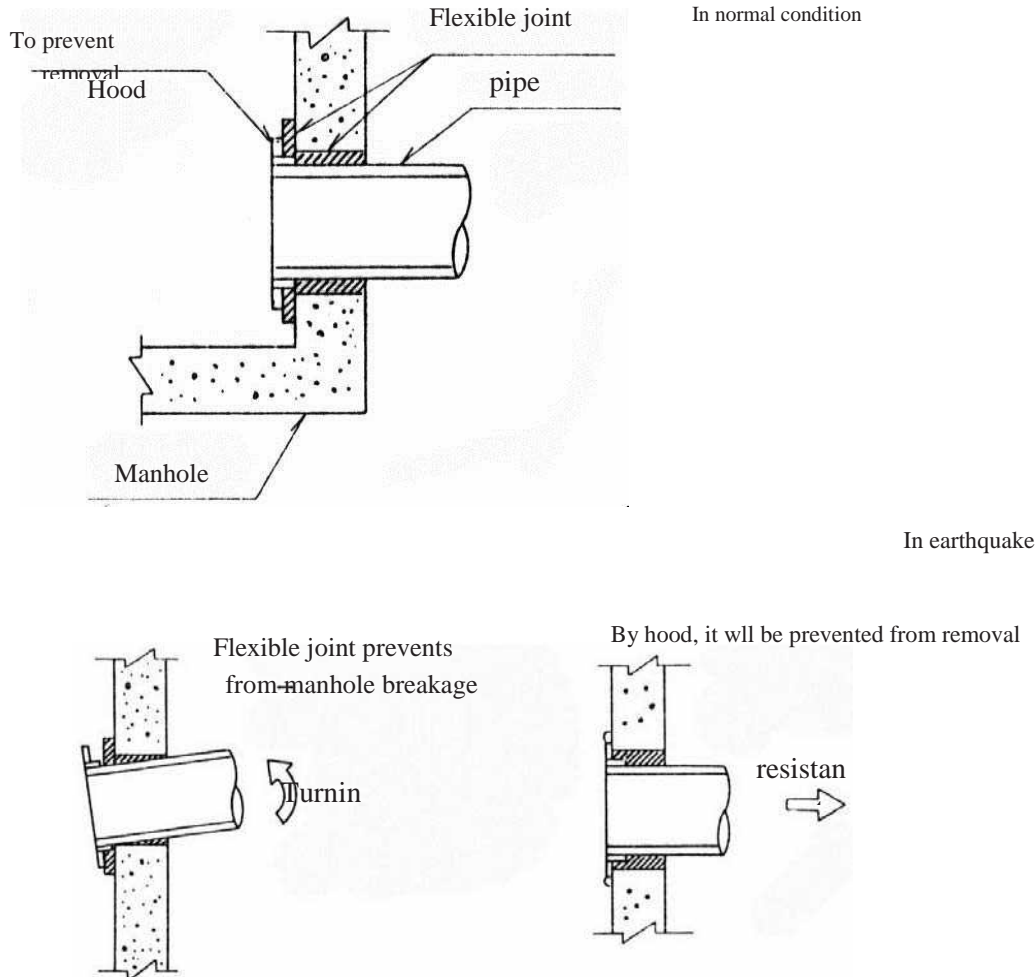

Figure 5-41- Short Shield Concrete Pipe

(9) Short shield plastic pipe:

A short shield pipe is used in manhole and pipe connection place and it will be prevented from removal. Pipe material is hard plastic material and it is shaped as a cone to increase shield resistance rate. In main body of manhole, a short shield pipe joint is installed and then it will be sent out of manhole because the last part can completely stick to the wall.



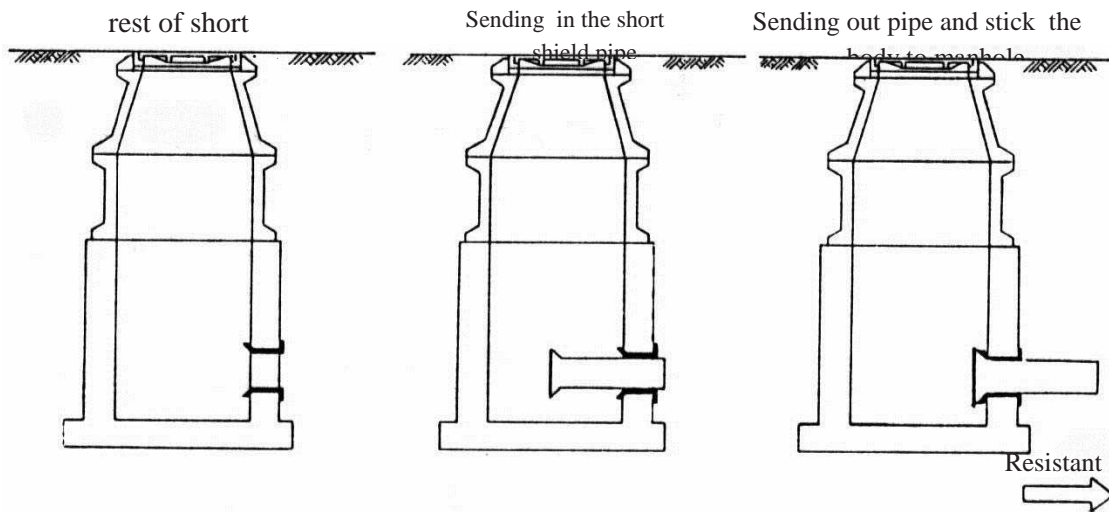

Figure 5-42- Short Shield Plastic Pipe

(10) Manhole flexible joint:

To create flexibility in bending, expansion and constriction of pipe joint in manhole wall, a flexible joint is installed.

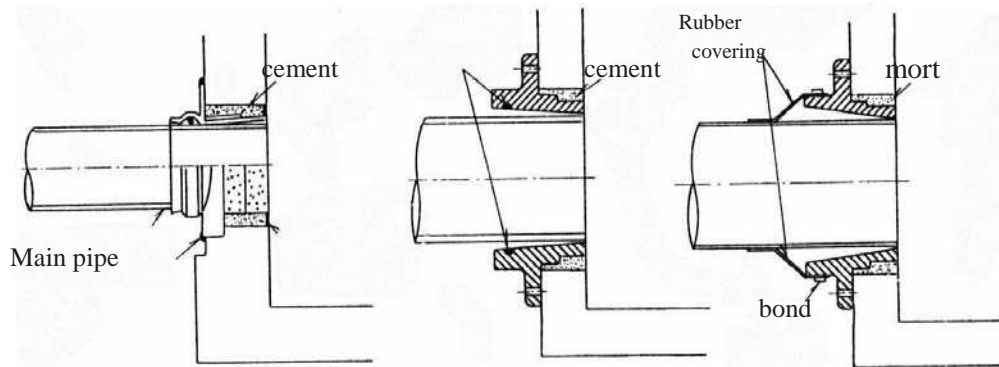

Figure 5-43- Manhole Flexible Joint

(11) Manhole rubber joint:

A rubber joint will be installed in pipe and manhole connection place. To send in the pipe to existing pore in manhole adhesive material will not be used. Joint is installed and tightened only by a semicircle rib which is compressed by a ring.



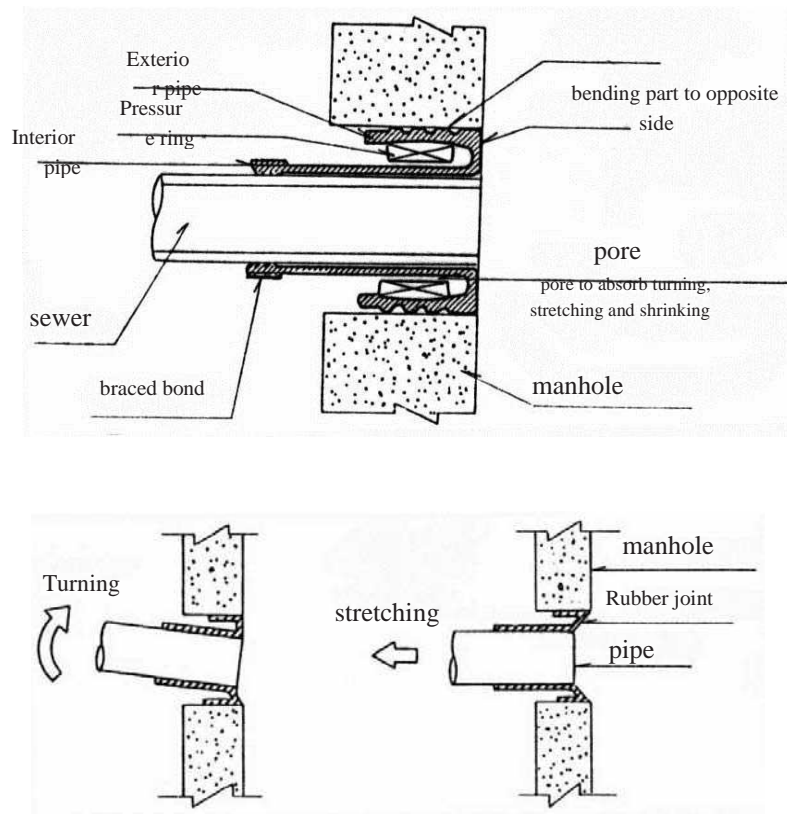

Figure 5-44- Manhole Rubber Joint

(12) Manhole to pipe casing joint:

Pipe and manhole connection is developed as a pipe casing and it will prevent pipe removal. Pipe casing is combined of flexible plastic pipe and also strengthened plastic, and is installed inside main pipe casing which has ability to sliding.



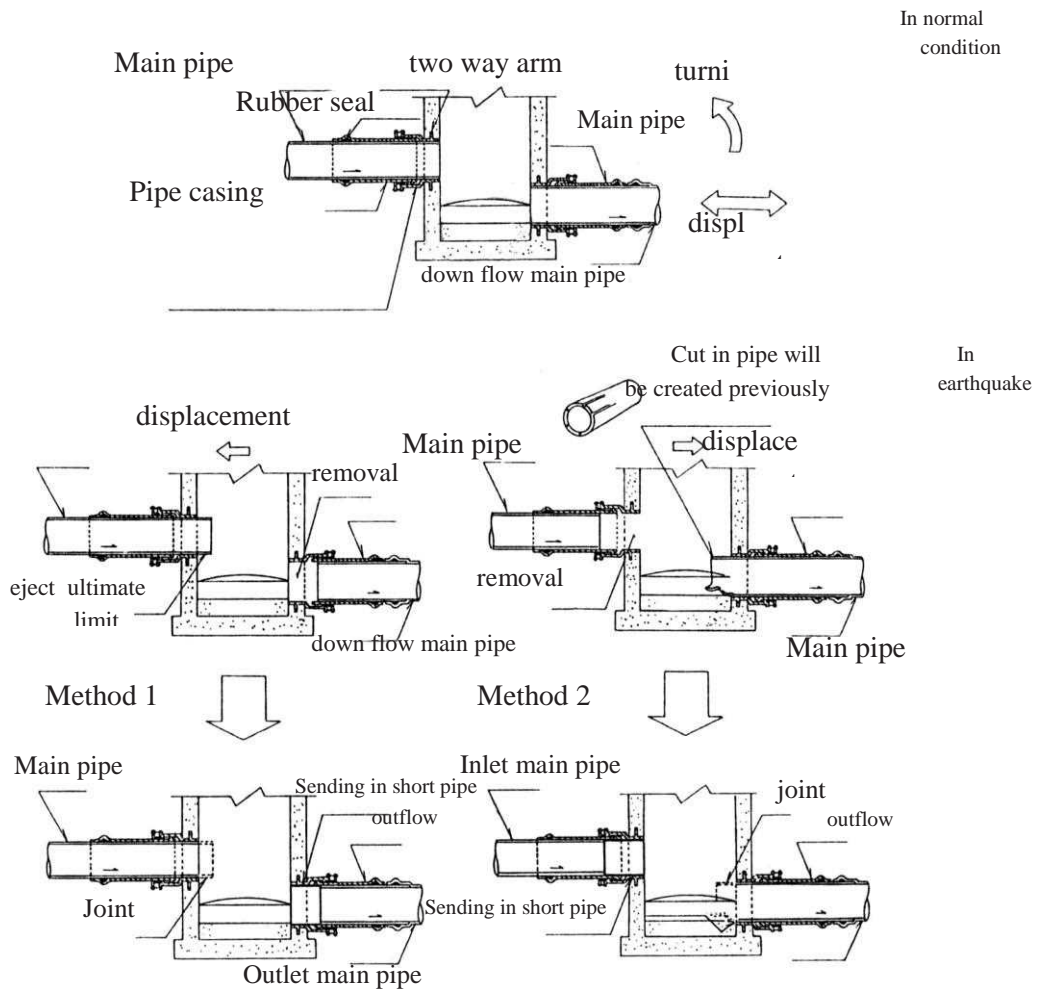

Figure 5-45- Manhole to Pipe Casing Joint

(13) Two kind of pipe connection to manhole:

Connected pipe to manhole is double layer (exterior and interior pipes) and there is an insulation rubber between them. This set has necessary flexibility against bending, expansion and contraction.



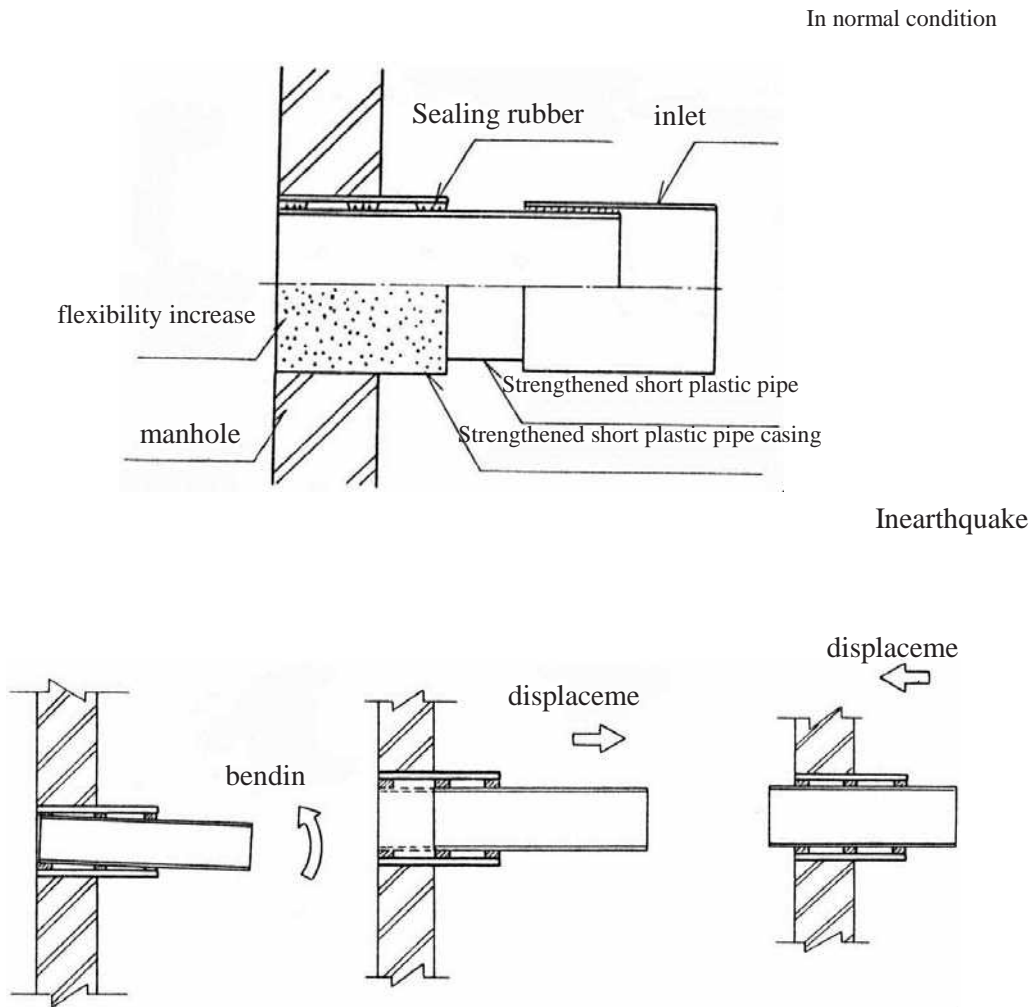

Figure 5-46- Two Kind of Pipe Connection to Manhole

Manhole circular joint:

(14)A circular section to increase capacity of rotation in manhole sidewall and on the other side inlet pipe has ability of sliding and can be adopted by expansion and contraction condition.

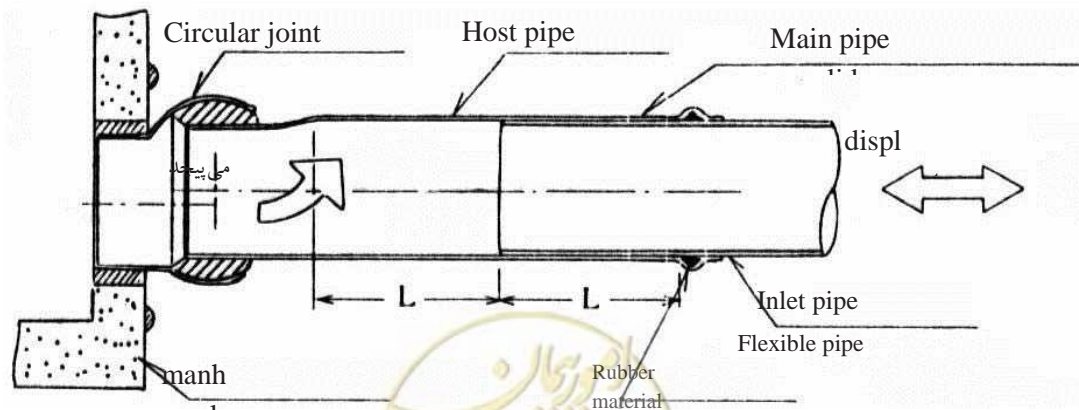

Figure 5-47- Manhole Circular Joint

(15) Joint with hollow ring:

A joint with a ring of water stop compressed material is developed in the pore between pipe and manhole. Pipe by ring joint is installed in open part of manhole and after entering filling material inside the ring joint, manhole and joint are stucked hardly by water stop material.

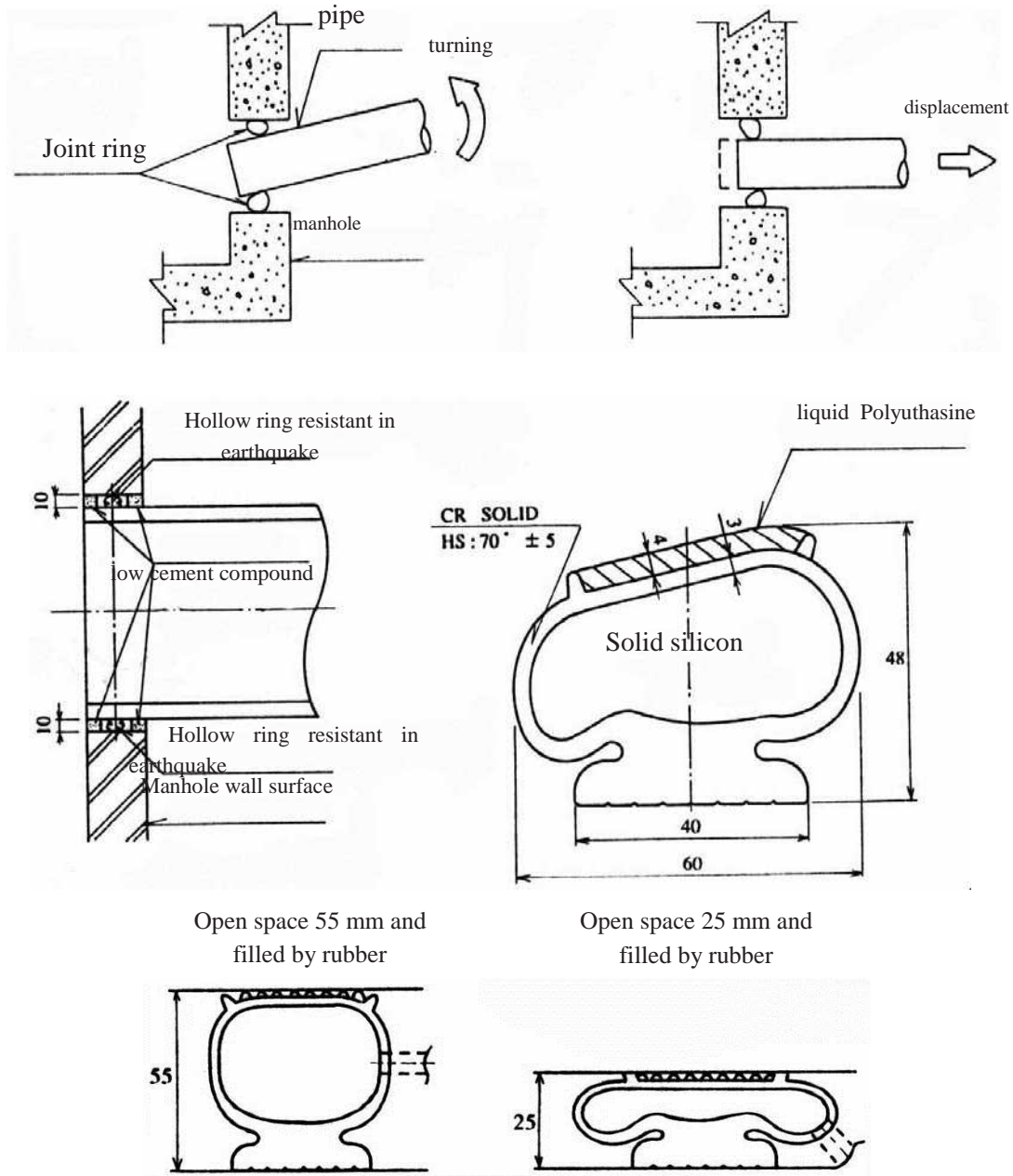
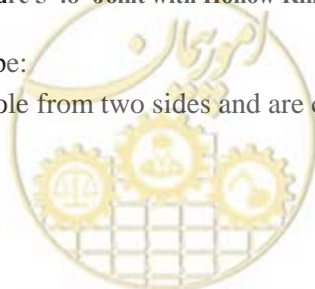

Figure 5-48- Joint with Hollow Ring

(16) Manhole with contiguous pipe:

Water pipe is sent in the manhole from two sides and are connected together inside the manhole by a casing pipe segment.



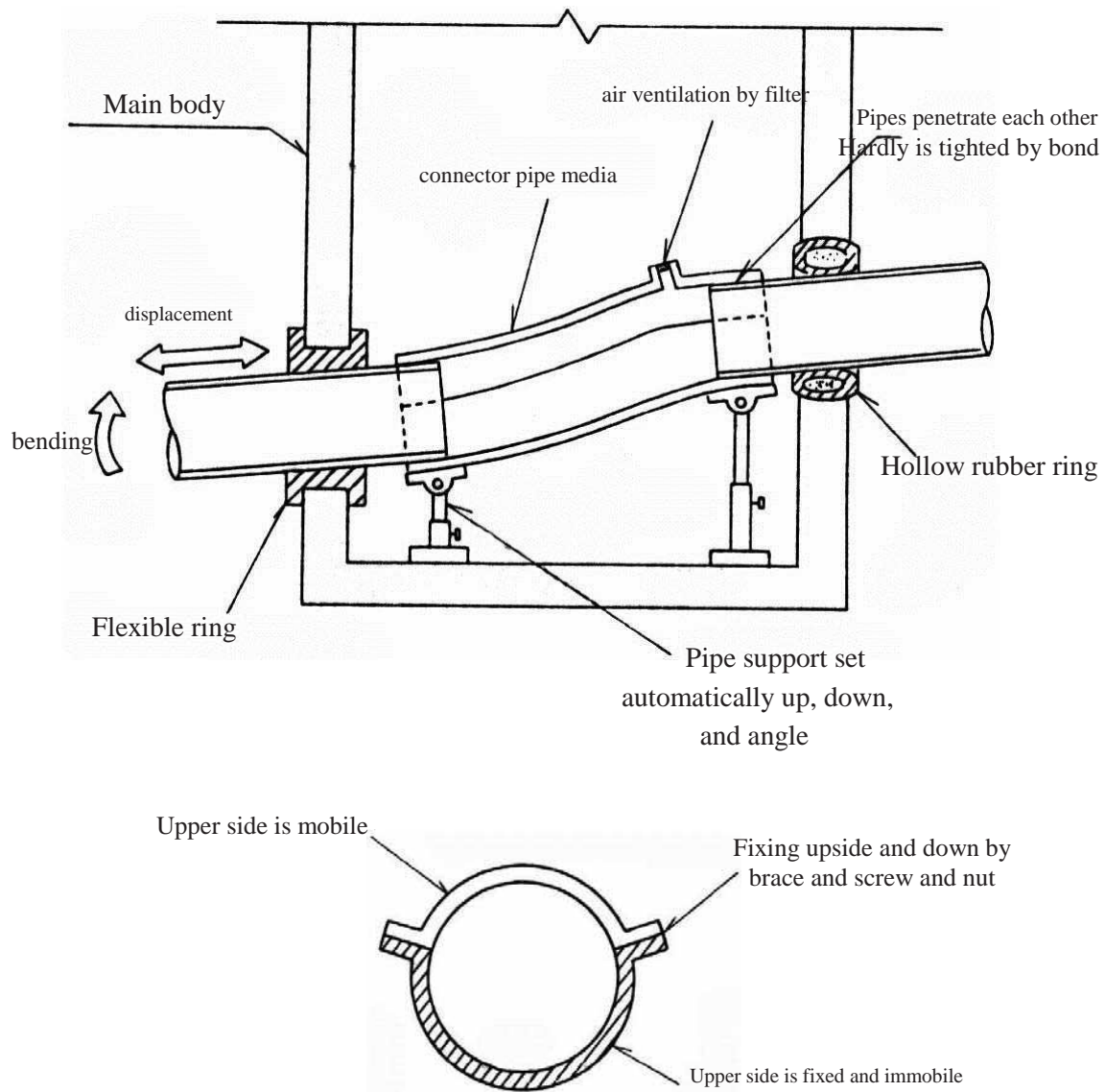

Figure 5-49- Manhole with Contiguous Pipe

(17) Manhole with flexible side chamber:

A side chamber is installed in manhole and pipe connection to absorb displacement by main body and pipe movement in the earthquake.



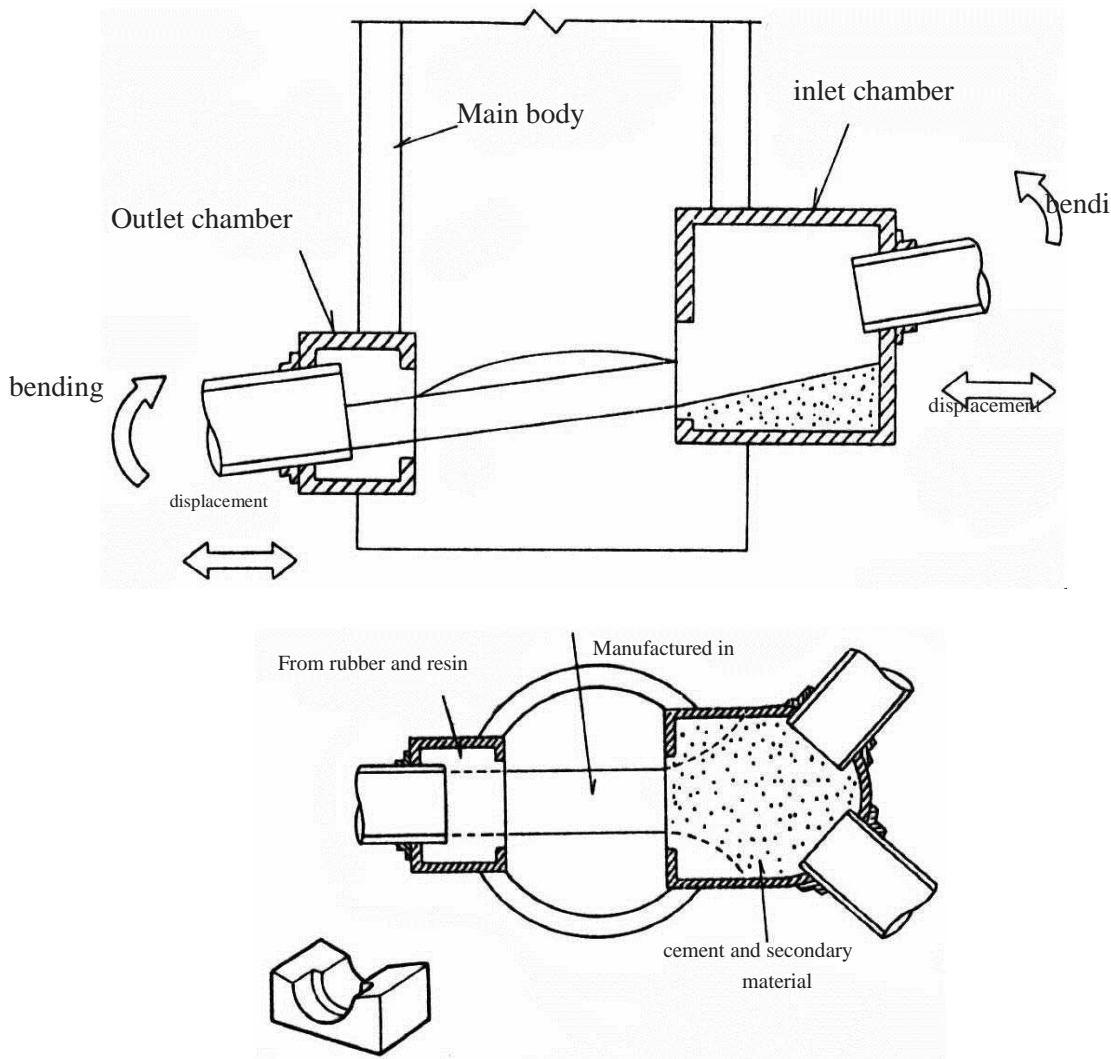

Figure 5-50- Manhole with Flexible Side Chamber

5-2-3-3-Pipe Joining Equipment

5-2-3-3-1-Failure Modes

Pipe equipment due to ground surface motion in earthquake encounter stretching, compressing, displacement and also raising and settling, breakage, crack removal and the other damages. Since pipe equipment weight, which aeburied in soil, totally are lighter than removed soil, pipe motion is dependent on surrounding soil movement. Ground motion cause relative displacement in pipe and joints and it can cause different failure modes for pipe and joined segments according to figure 5-51 Intensity of failures are varied and depends on ground displacement distribution and mechanical characteristic of pipe and joints.



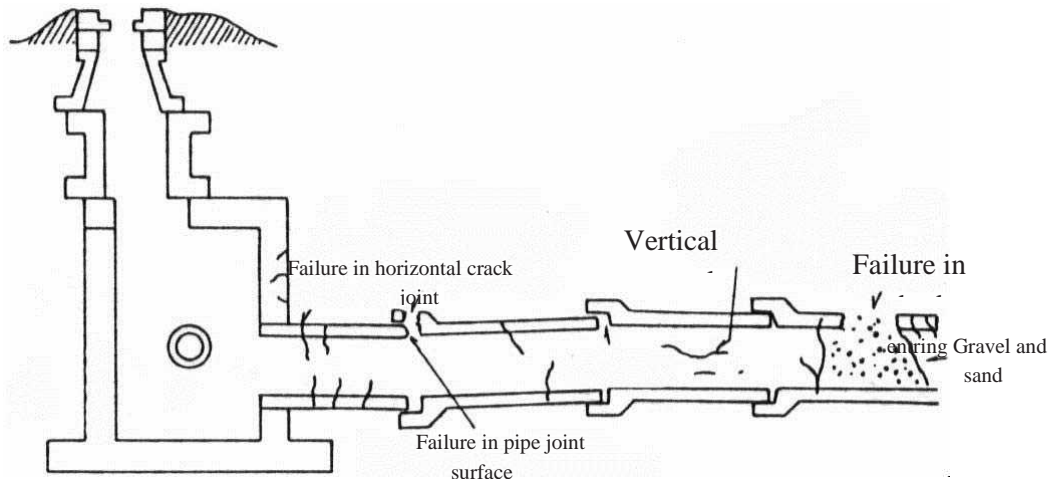

Figure 5-51- Various Failures in Pipe and Joined Segments due to Ground Displacements

5-2-3-3-2-Rehabilitation

Main failure modes in joined segments are created due to axial compression and stretching, proportionate rehabilitation method based on type of pipe and failure rate is presented in table 5-6.

Table 5-6- Rehabilitation Method Proportionate to Failure Modes

Failure mode		Rehabilitation Method
compression		concrete part is repaired, removal joint is sended out and necessary insulation is done, if necessary.
stretching	slight failure	No need to specific measures
	Below 13 mm	It is repaired by water insulation
	Between 13 to 25 mm	Flexible material of joint is replaced and is repaired by water insulation
	Higher than 25 mm	it is added to outside part of sealed wall or depend on rate and spreading losses a specific method for strengthening is considered, if necessary.

Following approaches can be used to confront pipe equipment failures:

- (1) In area under stretching, a structure is replaced another one with ability of tension and displacement.
- (2) In area under compression, a compound is used that has ability to absorb energy without failure in compression.
- (3) In area under bending, a compound should be used that possibly is resistant and flexible and soft.
- (4) In area under displacement, materials should tolerate absorbing relative displacement.

Examples of seismic rehabilitation methods for every failure mode are classified below.

(1) Pipe stretching in joint:

In cases like joint which stretching develops in pipe segment, a tight brace is used and as illustrated displacement is considered in extent that it can prevent flowing and ejecting material inside the pipe in displacement.

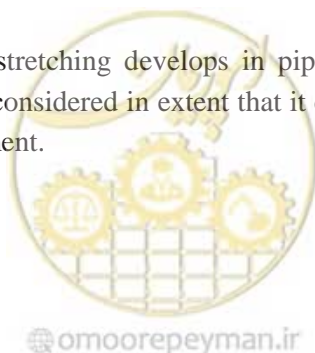

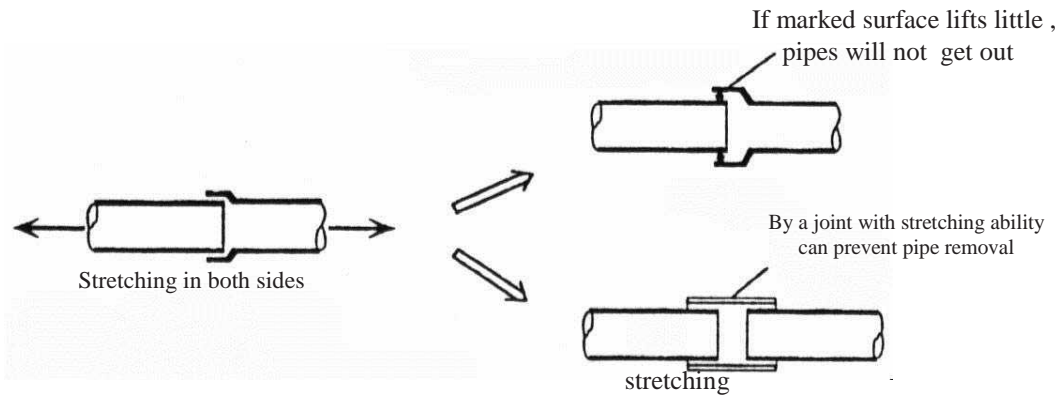

Figure 5-52- Rehabilitation of Pipe Sstretching Mode in Joint Place

(1) Pipe compression in joint place:

In sections like pipe joint to pipe and pipe to manhole where compression occurs same as shown in the figure below, structure should be constructed by compound or material resistant to compression.

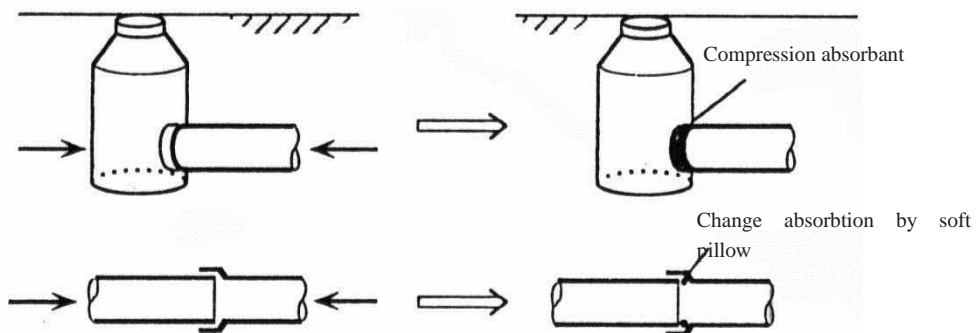

Figure 5-53- Rehabilitation of Pipe Compression Mode in Joint Place

(2) Pipe bending in joint place:

In area like joint place of manhole to pipe segment and pipe to pipe which is under bending, possibly flexible and resistant to bending material should be used.



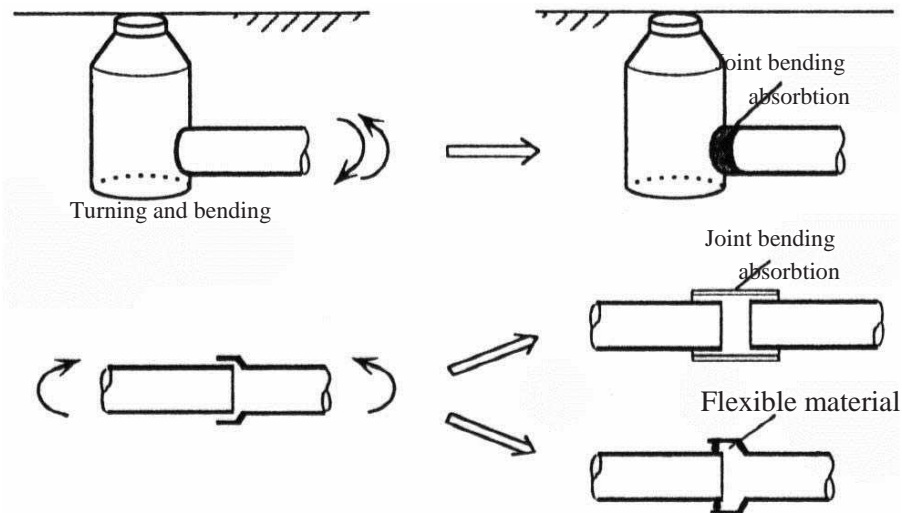

Figure 5-54- Rehabilitation of Pipe Bending Mode in Joint Place

(3) Shear in Manhole:

Relative displacements in manhole height cause shear in the segments and manhole material and joint place to pipe axis which tolerate the most shear force, should be able to tolerate and absorb shear deformation.

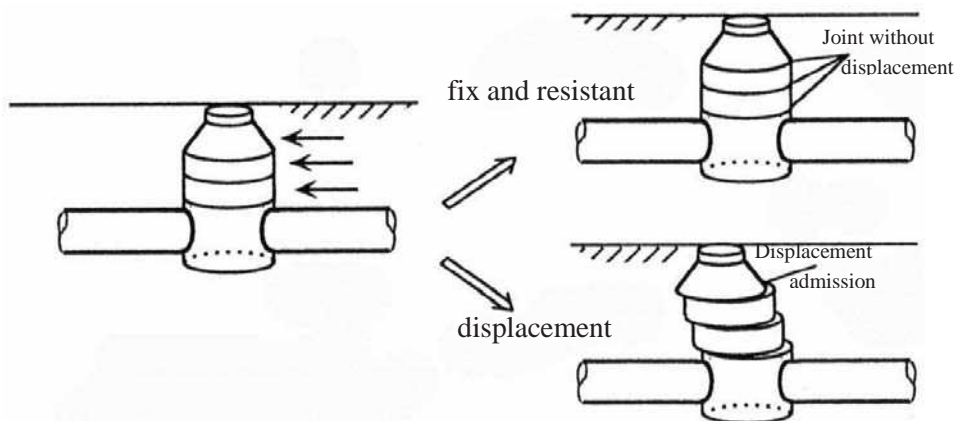

Figure 5-55 Rehabilitation of Shear Mode in Manhole

(4) Pipe and manhole buoyancy:

Because of pore water pressure increase in liquefaction due to earthquake, uplift force is imposed to the collection and in this case stability of structure should be provided by weight increase or anchoring to lower non-liquefied layer.



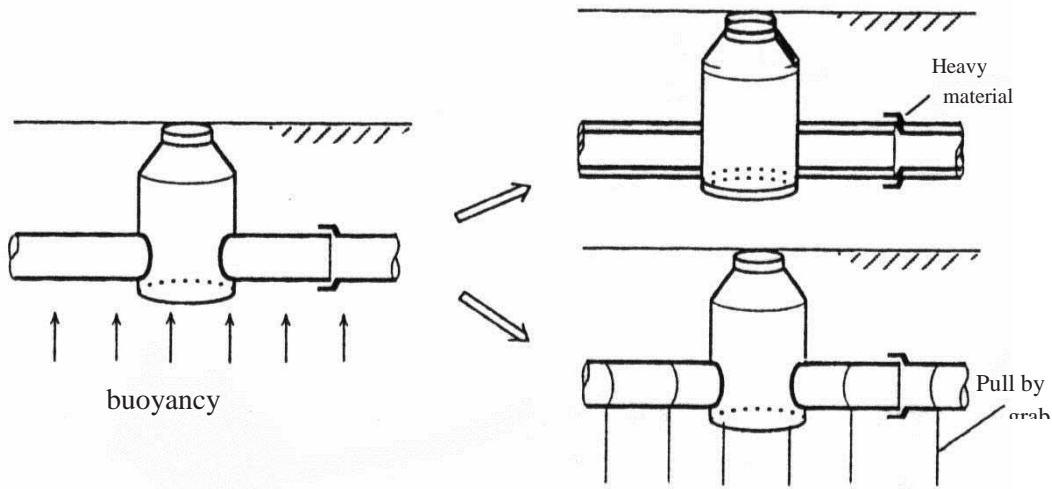

Figure 5-56- Rehabilitation of Pipe and Manhole Buoyancy Mode

(5) Hose pipe joint:

To control relative displacement between pipe and chamber or tank structure, a hose pipe, which its original compound is resin, can be used and through that relative motion modes can be controlled.

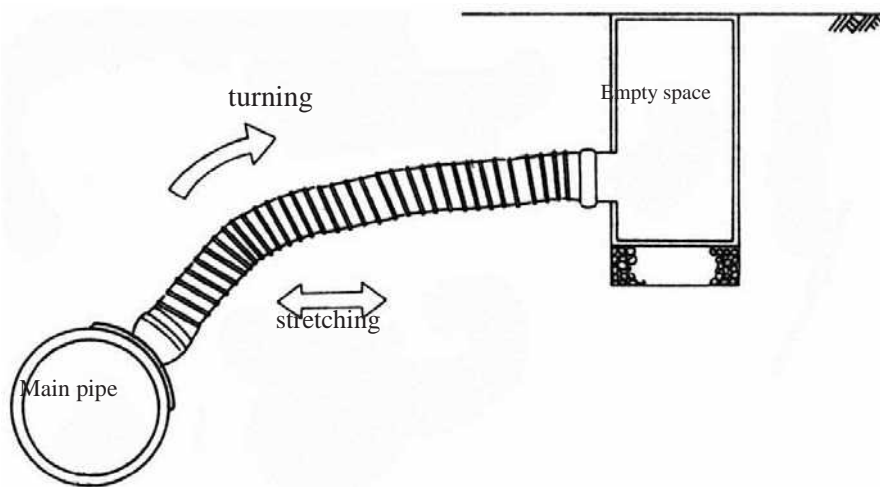

Figure 5-57 Hose Pipe Joint

(6) Flexible bending pipe:

Bending pipe can be used to control relative displacement between pipe and chamber or tank structure. These pipes have more ability to absorb deformation and tolerate better stretch and compression modes. This can be done by combination of two 90 degree elbow.



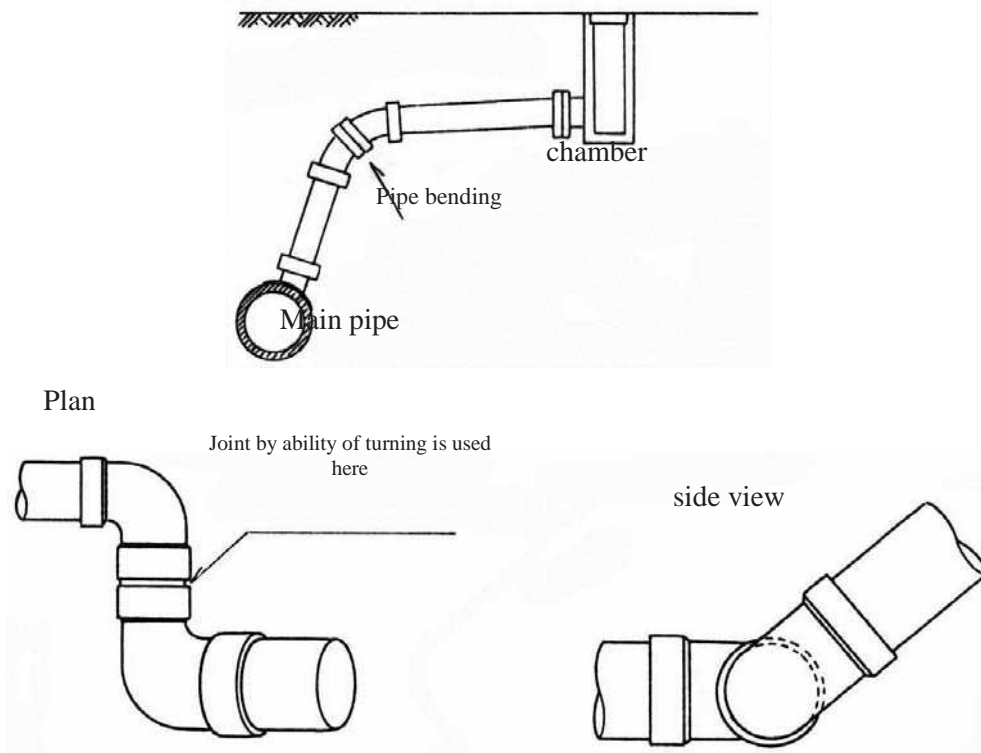
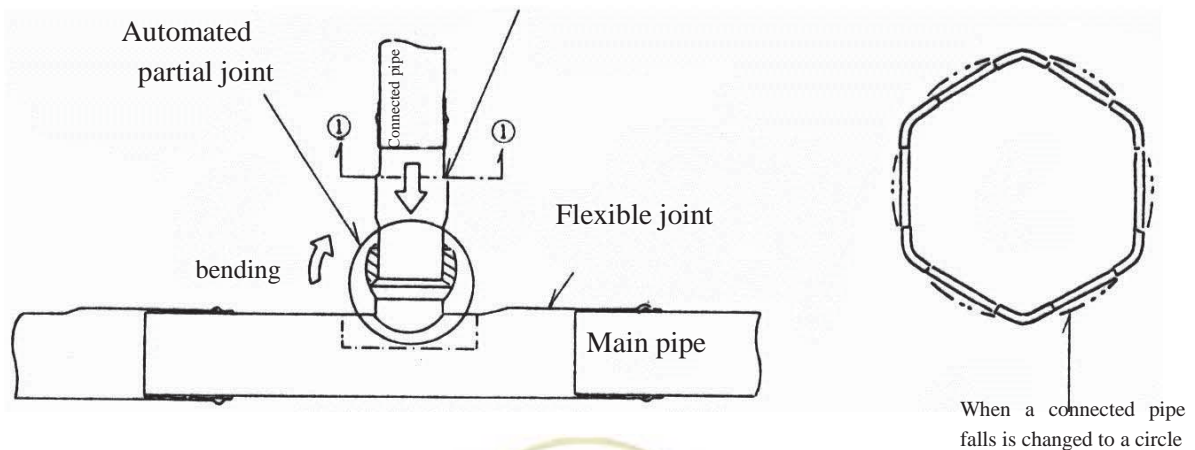

Figure 5-58 Flexible Bended Pipe

(7) Branch pipe flexible joint:

Using method indicated in figure 5-59, a flexible joint is developed in subsidiary and main pipe connection to prevent force transfer between pipes and stress focus on joint place.

In normal condition it is divided as a hexangular and prevents pipe falling, when a connected pipe falls is opened as a circle and prevents leakage



When a connected pipe falls is changed to a circle

Figure 5-59 Branch Pipe Flexible Joint

(8) Flexible transition:



A resistant joint can be developed by installing an integrated tee in pipe transition further to availability to both pipes by increasing resistancy and ductility in tee.

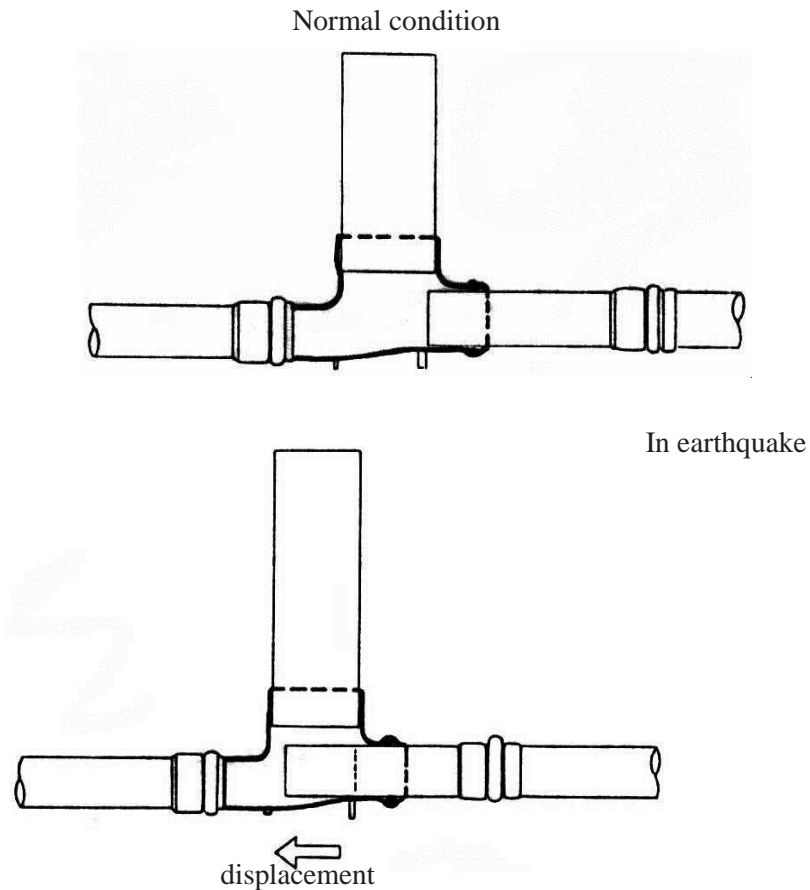

Figure 5-60 Flexible Transition

5-2-4- Other Non-Building Structures

5-2-4-1- Main Components

(1) Conduit:

Rectangular concrete conduit section is connected by two-way replacement mechanism. As indicated in figure 5-61, common failure mode of concrete conduit is due to earthquake from shear curvature of cross section or joint failure due to axial displacement or bending deformation. Another kind of this conduit is made of metal waved sheets which has limited application.



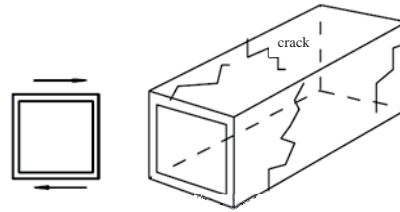

Figure 5-61- Common Failure Modes o

Direction due to Tension Deformation)

(2) dike:

Sloping dike should maintain stability due to earthquake and should not encounter failure modes such as slope sliding and lateral spreading. If there is sealed surface in channel coating, channel deformation should be in such extent that surface material crack and failure does not occur.

5-2-4-2-Water Duct

5-2-4-2-1-Seismic Failures

In earthquake, seismic failures to concrete ducts occurs in structure joints and crevices.



Figure 5-62 Crevice in Concrete Duct with Square Section due to Earthquake

(1)Concrete duct main failure mode

Concrete duct main failure mode, in definition, is pipe element in ultimate limit state.

(2)Concrete duct medium failure mode

Concrete duct medium failure mode, in definition, is pipe element in ultimate limit state and not in operation limit state.

(3)Concrete duct minimal failure mode

Concrete duct minimal failure mode, in definition, is pipe element in operation limit state.

Structural failure modes related to structure components is summarized in table 5-7



Table 5-7 Structural Failure Modes

Section	Failure mode	Evaluation		
		Minimal	Medium	Main
Concrete duct	Corrosion	No need to bar repair	If the other reducing effects can remove risk in an acceptable level, in high failures, defective member repair is not allowed	Repaire Bar inside concrete due to high corrosion
	Crack	No need to non-structural crack repair		Repaire Failures higher than allowed limit
	Fossa	No need to shallow fossa repair		
	Deformation	No need to small displacement repair		
Joint to side feet	Soil settling	No need to small displacement repair	If the other reducing effects can remove risk in an acceptable level, in high failures, defective member repair is not allowed	Repaire Failures higher than allowed limit
	Soil sliding			
Crevice	Crevice distance	No need to small displacement repair		

5-2-4-2-2-Assessment

There are various problems about concrete conduit. Following list is problems in concrete conduit which is in criteria class related to resistancy.

- Cracking in rigid concrete conduit
- Scour and losing structural support
- Loosing concrete conduit aqueduct due to corrosion or friction.
- Excessive bending and deformation of flexible concrete conduit
- Cracks due to flexible conduit stress
- Crack tip opening of concrete conduit under ground shaking impact
- Settling and increasing crevice due to permanent ground deformation which are created because of fault displacement or liquefaction due to ground motion.



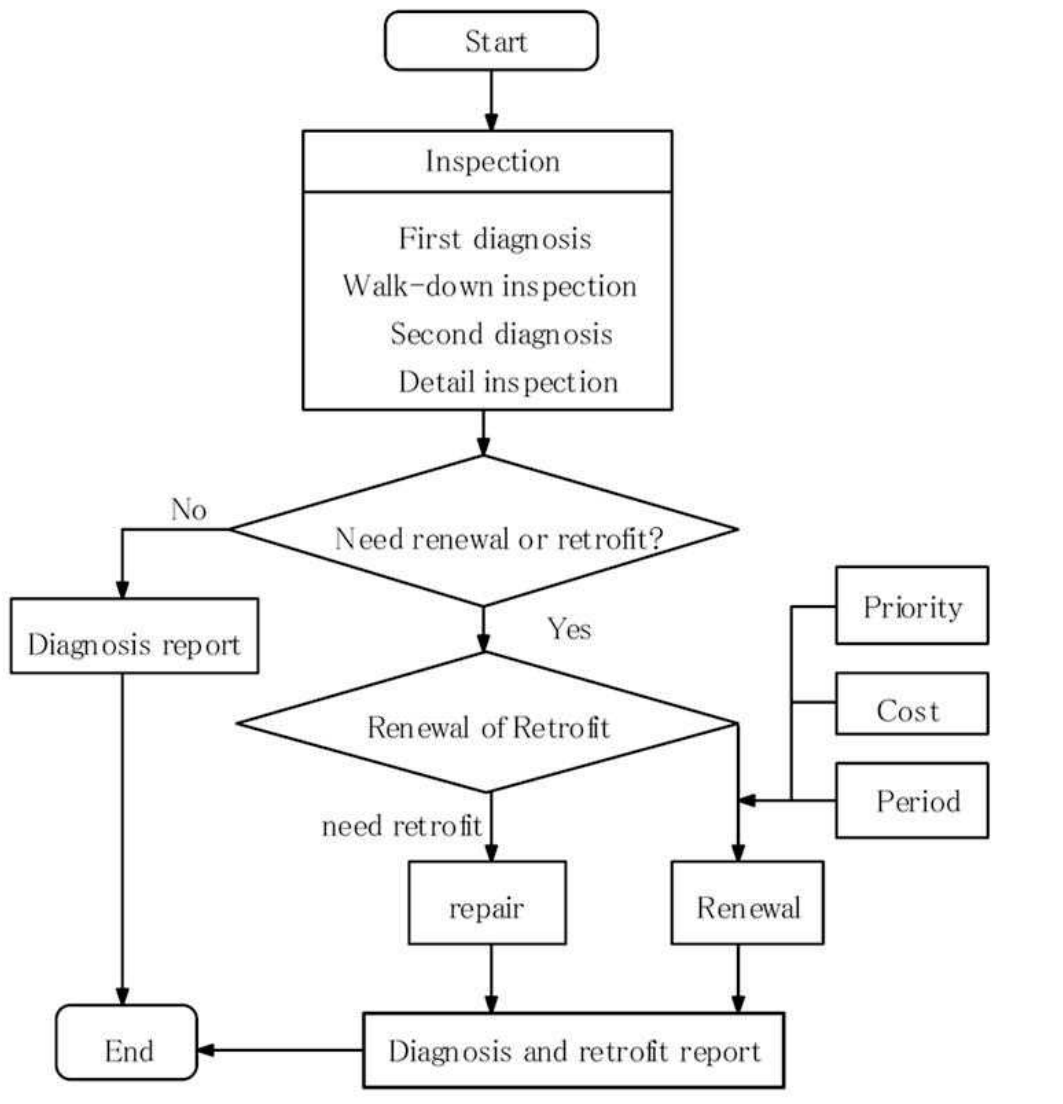

Figure 5-63- Flow Diagram of Concrete Conduit Seismic Assessment

5-2-4-2-3-Retrofitting

In concrete conduit design it is better to emphasize considering requirements of maintenance period. It means that in design process considering type of conduit, material quality and the way of constructing, there is a need to minimal maintenance and repair. Although structural condition is one of the important matters in concrete conduit function, but the problems related to stability is the most replacement causes. Concrete conduit often will be worn out as structural break. Stability of these structures is affected by two mechanisms: Corrosion and friction. Durability of material in concrete conduit and the other drainage structures is an important issue. In stiff environment, corrosion and friction cause wear in all existing material of concrete conduit. In fact, corrosion is metal wearing due to chemical and electrical reaction of the environment. Corrosion of concrete conduit material may occur in wastewater and different soils. The wastewater and soils may contain acidic material, alcohol, dissolved solines, organics, chemicals or



industrial wastes, mine sewage, sanitary sewage and dissolved or free water. However, concrete conduit corrosion is related to the sewage and chemicals which is reacted, dissolved or carried by water.

To design new concrete conduit and main repairs of existing concrete conduit, economical analysis usually is done considering factors such as construction cost, estimated life time, maintenance cost, replacement cost, breakage risk and financial losses risk.

The most economical concrete conduit is not necessarily concrete conduit by minimal initial cost and the longest operation life, but low and long time costs should be considered in main design and repair or replacements.

Various types of lining material are used only or combined as different layers to protect concrete conduit against corrosion or chemical effects. Different kinds of linings depend on material type and wearing or probability of occurrence will be different. Necessity of lining depends on factors such as followings:

- Acidity and chemical characteristics of surrounding soil
- Acidity and chemical characteristics of passing water from concrete conduit
- Particle size and transfer rate of soil material of concrete conduit
- Environmental effects including frozen and melted water

Corrugated steel conduit is protected by zinc metal layer (Galvanized) or aluminium. Protective lining for metal concrete include tar lining, tar floor cover, tar fiber lining, polymer, and concrete floor cover. Protective lining with metal lining are used in high corrosion or friction. Concrete conduit rarely lined when constructing. But if they are installed in areas with chemical invasion, they will be covered by epoxy resin or special concrete with high density and low porosity. These concretes have high resistancy against chemical material and effects. In the most cases concrete conduits are constructed under the heavy embankments and under roads with high traffic volume. Replacing this kind of concrete conduit will be costly and will cause stopping road traffic. Hence, apparent repair and retrofitting methods should be precisely evaluated.

5-2-4-3-5-Dike

5-2-4-3-5-1-Assessment

Assessment and retrofitting plan in dikes is identified by the following flow diagram.



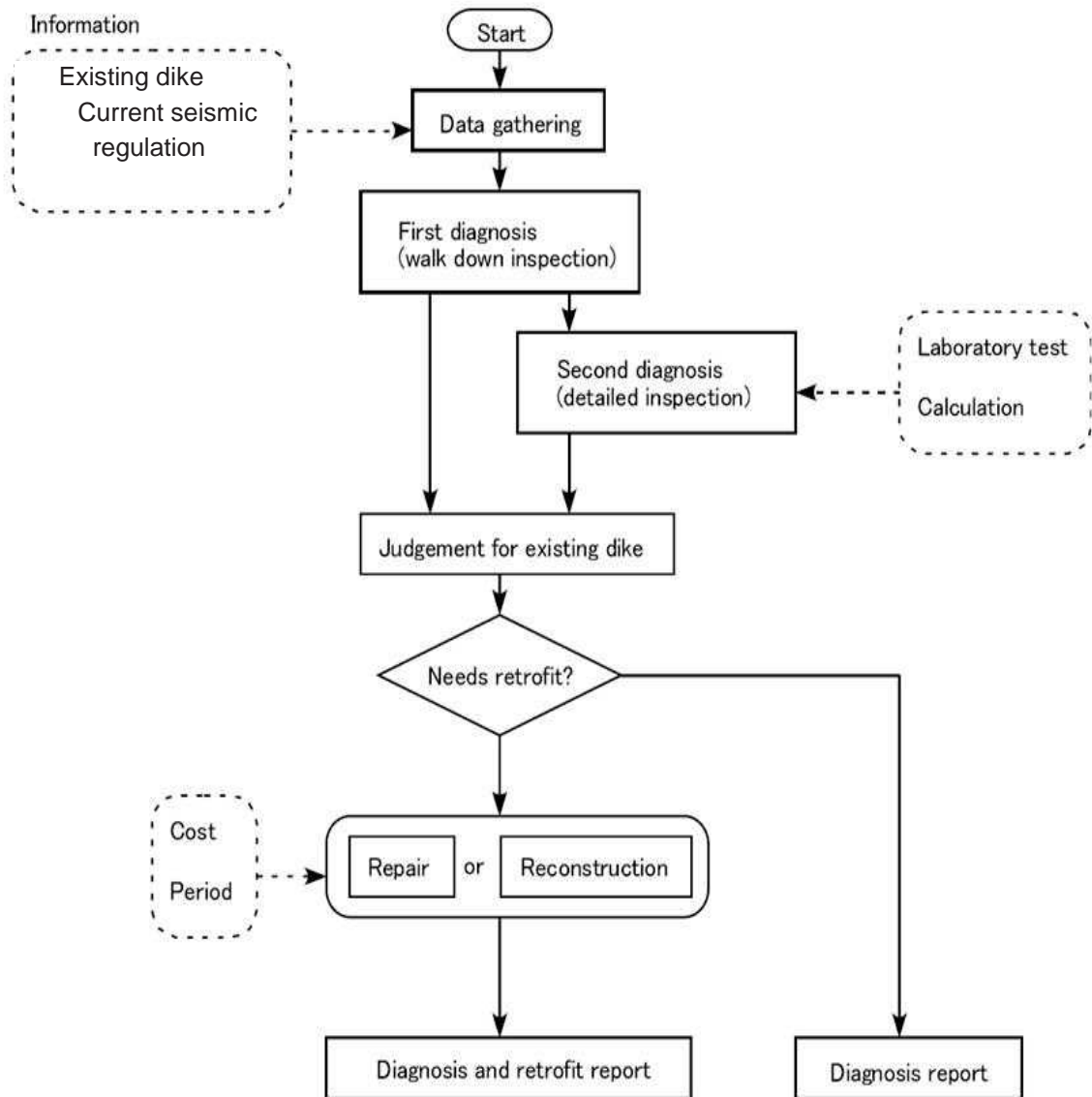

Figure 5-64 Flow Diagram of Dike Seismic Assessment

5-2-4-3-5-2-Retrofitting

First priority of investigation should be about main body of dike. Second priority is related to joined parts of dike body such as surface and staircase. About retrofitting main body choosing appropriate way like concrete conduit in the viewpoint of safety, practically, and cost, should be done as stated in previous section. In case of surface crevices rubber flexible and stainless material should be used.

5-2-4-4-Buildings

Seismic retrofitting of the structural buildings should be done based on Instruction for seismic rehabilitation of existing buildings, No.360, President deputy strategic planning and control.

