

Islamic Republic of Iran
Vice Presidency for Strategic Planning and Supervision

Guideline for Seismic Design of Power supply systems

No. 602

Office of Deputy for Strategic Supervision

Department of Technical Affairs

nezamfanni.ir



omoorepeyman.ir

Chapter 4- Seismic Design and Safety Control of Method

[Placeholder text for Chapter 4 content]

Chapter 5 - Seismic Design and Safety Control of Power Plant Equipment

[Placeholder text for Chapter 5 content]

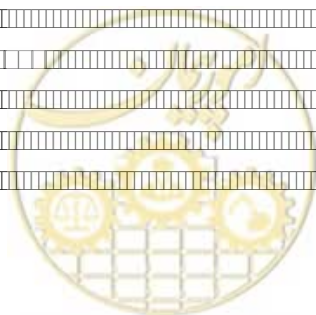

Table of contents for the first part of the book, listing chapters and their corresponding page numbers. The text is rendered as a series of placeholder boxes.

Chapter 6- Seismic Design & Safety Control Petroleum Fuel Reservoirs

Table of contents for Chapter 6, listing sub-sections and their corresponding page numbers. The text is rendered as a series of placeholder boxes.

Chapter 7- Seismic Design & Safety Control Gas Fuel Tanks

Table of contents for Chapter 7, listing sub-sections and their corresponding page numbers. The text is rendered as a series of placeholder boxes.

Chapter 8- Seismic design and safety control power plant piping



[This section contains multiple lines of placeholder text, represented by rectangular boxes, indicating where content has been redacted or is otherwise obscured.]

Chapter 9- Seismic design and safety control of electrical posts

[This section contains a few lines of placeholder text, represented by rectangular boxes.]



Table of contents (Placeholder text)

Chapter 10- Seismic design and safety control of transmission and distribution lines

Chapter 10- Seismic design and safety control of transmission and distribution lines (Placeholder text)

Appendixes

Appendixes (Placeholder text)



Blank lined area for text content.



| | | | |
|--|--|--|--|
| | | | |
| | | | |
| | | | |



Chapter 1

General



1-General

This guideline has been developed based on similar documents in the high seismicity countries together with local experiences and experiences from other countries outstanding in the field of earthquake engineering. In line with gaining from other countries' experiences; it has been tried to pay attention to the localization issue and present subjects more simple and practical.

1-1-Objective

The objective of this guideline is to secure public safety and prevent serious damage to power systems due to earthquake

- Iran 2800 code and Iran's National Building Regulations are used for seismic design of the structures of this system
- Subjects regarding to National Building Regulations, chapter 4, issue 360 and issue 123 can be used for seismic design for foundation of equipment together with results extracted from seismic design of related instrument from this guideline.

1-2-Scope

Intended installations of this guideline are installations of power system including refinery components, substations, transition lines and distribution networks.

- Vulnerability against earthquake is very critical, so the objective of this guideline is to secure acceptable safety regarding to rational risk on the basis of economic conditions and the nature of earthquake hazard and vulnerability of natural gas systems.

The aim of this guideline is to no serious and interfering public safety damage occur by observance of its content

1-2-1-Organization of this guideline

This guideline was organized with above mentioned objectives and scope into following chapters:

Chapter 1: general

Chapter 2: principles

Chapter 3: seismic loading

Chapter 4: seismic design and safety control methods

Chapter 5: Seismic Design and Safety Control Power Plant Equipment

Chapter 6: Seismic Design & Safety Control Petroleum Fuel Reservoirs

Chapter 7: Seismic Design & Safety Control Gas Fuel Tanks

Chapter 8: seismic design and safety control power plant piping

Chapter 9: seismic design and safety control electrical posts

Chapter 10: seismic design and safety control transmission and distribution lines

Appendix



1-2-2-Application notes

Since this document is the first narrative of the respective guideline in the country, like previous guidelines and regulation, the presence of ambiguity and impediments is a normal issue. For lessen these difficulties and remove them as soon as possible, it is worthwhile to consider following notes:

1-It has been tried to remove any contradictions between regulations of this guideline with Iran 2800 code.

2-In the case of scarcity of information about loading intended gas distribution system in this guideline, topic six of National Building Regulations can be implemented.

3- For designing concrete components of intended gas distribution facilities in this guideline, especially concrete material characteristics, issue 123 and topic 9 of National Building Regulations can be implemented.

4-Topic 10 of National Building Regulations is complementary for obviate any shortcomings regarding steel components of its electrical facilities.

5-Other similar guidelines and documents which occasionally were prepared and developed by internal or external qualified bodies for seismic design of gas distribution systems can be implemented in coordination with this guideline.

6-It is expected from all users of this guideline to send their corrections and recommendations for its better compliance and easier implementation in the country to be used for developer in the future versions.

1-3-Related codes and regulations

1-3-1-Normative references

Various standards, codes, regulations, guidelines and manuals were used in the development of this guideline. The most important of them are as following:

Iran 2800 Code: Iranian Code of Practice for Seismic Resistant Design of Buildings, Standard No. 2800, Building and Housing Research Center, 2005

Euro code 8: Design rules for the earthquake-resistant structures, Part 4: silos, storage tanks and pipeline systems, European Committee for Standardization, 2006

BCJ1997, Building Center of Japan, 1997

Japan Gas Association: Manual for seismic design of high pressure gas pipeline for liquefaction, JGA-207-01, 2001

Japan Road Association: Specifications for Highway Bridges, Part V, Seismic Design, 2002

Japan Gas Association: Recommended steps for LNG containers above the ground, August 2002

Building Center of Japan (BCJ): manual for structural design and building stacks, 1982 (Stack-82)

Architecture Institute of Japan: Manual for seismic design of crane, May 1989

High Pressure Gas Safety Institute of Japan (KHK): Seismic Design Code for High Pressure Gas Facilities, 2006

Technical Journal of Telegraph and Telephone Corporation (NTT): design technology of spatial structure (1-3), August, September and October 2007



1-3-2-Code Abbreviations

| Abbreviation | Full Name |
|--------------|---|
| AIJ1996 | Recommendations for designing storage tanks and their Supports, Architecture Institute of Japan, 1996 |
| ALA2005 | Seismic Guidelines for water Pipelines, ALA, 2005 |
| ANGTS | Complementary applicable technical information of Alaska State, Alaska Natural Gas Transportation System, 2004 |
| API 5L | API Specifications for Line Pipe L5, Pipeline specification, API, 2004 |
| API620 | API 620 standard, Design and manufacture, Design and Construction of Large, Welded, Low-Pressure Storage Tanks, API, 2005 |
| API650 | API 650 Welded Steel Tanks for Oil Storage, API, 2005 |
| ASCE7 | Minimum Design Loads for Buildings and Other Structures, ASCE, 2006 |
| ASCE1984 | Seismic Design Guidelines for oil and Gas Pipeline Systems, ASCE, 2006 |
| ASCE1985 | Design of Structures to Resist Nuclear Weapons Effects, Manual 42, ASCE, 1985 |
| ASCE1997 | Guide lines for seismic evaluation and design of petrochemical facilities, ASCE, 1997 |
| ASME B31 | ASME B31 Code for Pressure Piping, ASME B31, 2004, AWWAD100-96 |
| AWWA96 | AWWAD100-96 |
| BCJ1997 | Specifications of seismic design for building components, Building Center of Japan, 1997 |
| BS EN1998-1 | Euro code 8: Design of structures for earthquake resistance. Part 1, General rules, seismic actions and rules for buildings, European Committee for Standardization, 2004 |
| BS EN1998-4 | Euro code 8: Design rules for the earthquake-resistant structures, Part 4: silos, storage tanks and pipeline systems, European Committee for Standardization, 2006 |
| BS EN1998-5 | Euro code 8: Design of structures for earthquake resistance – Part 5: Foundations, retaining structures and geotechnical aspects |
| IBC2006 | International Building Code, USA, 2006 |
| INBC10 | Iranian National Code, Part 10, design and construction of steel structures |
| IPS-X-XX | Iranian Petroleum Standards |
| Iran2800 | Iran 2800 Code: Iranian Code of Practice for Seismic Resistant Design of Buildings, Standard No. 2800, Building and Housing Research Center, 2005 |
| Iran519 | Iran 519 Code, loading of Buildings |
| JIS B8501 | Japanese Industrial Standard, JIS B8501, Welded Steel tanks for oil storage, 2001 |
| JGA1982 | Recommended methods for earthquake-resistant design for high and medium pressure gas pipelines, Japan Gas Association, 1982 |
| JGA2000 | Recommended methods for earthquake-resistant design for high pressure gas pipelines, Japan Gas Association, 2000 |
| JGA2001 | Recommended methods for earthquake-resistant design for high pressure gas pipelines in the areas with potential of liquefaction, , Japan Gas Association, 2001 |
| JRA74 | Technical Standard for Oil Pipelines, Japan Road Association, 1974 |
| JRA V | Design Specifications for Highway Bridges, Part V: Seismic Design, Japan Road Association, 1996 |
| JSWA2006 | Seismic Design and Construction Guidelines for Sewage Installations, Japan Sewage Works Association, 2006 |
| JWWA1997 | Seismic Design and Construction Guidelines for Water Supply Facilities, Japan Water Works Association, 1997 |
| KHK | Technical Seismic Design Code for High Pressure Gas Facilities, High Pressure Gas Safety |

| Abbreviation | Full Name |
|----------------|--|
| | Institute of Japan (KHK), 2000 ^o |
| MCA22 | MCA Safety Manual 22 |
| MIAC No.30 | Seismic Design Appendix for Fire Defense, Directive No. 3, Ministries of Communications and Internal Affairs, 2005 |
| NIOEC-SP-XX-XX | NIOEC Specifications |
| NZ1981 | Seismic Design of Petrochemical Refinery, Ministry of Energy, New Zealand, 1981 |
| NZ1986 | Seismic Design of Storage Containers, Ministry of Energy, Recommendations of Study Group of New Zealand National Association for Earthquake Engineering, New Zealand, 1986 |
| WSP064 | Design Standard for Water Pipe Bridge, WSP 064-2007, Metallic Water Pipe Association |
| UBC97 | Uniform Building Code, USA, 1997 |



Chapter 2

Principles



2-Principles

Principles regarding earthquake design, design methods (safety control) and anticipated performances are presented summarily in this chapter. The most important of these principles are:

- 1- Two risk level following Iran 2800 code with attention to two acceleration and velocity spectrum compatible with Iran's condition and in accordance with regulations of Standard No. 2800
- 2- Consideration of earthquake load in two types including inertia force due to the acceleration effect in mass that exerted in to gravity mass center or centers and the force due to earth displacements and its application through interaction of soil and buried structure to the body in the contact with soil.
- 3- Using two method for design and safety control including allowable stress in the elastic limit of material behavior for risk level 1 and ductility method in non-elastic of material behavior for risk level 2
- 4- Using two level of performance as damage limit and ultimate limit which unceasing utilization and minimum cease are secured in the former and latter, respectively. With regard of the behavior of structural components, that remains undamaged in the elastic limit, in the former, but in the latter, passes from the yield boundary but bounds to the certain allowable limit of plastic deformation. This allowable limit after yield-allowable ductility- is determined by this guideline according to experimentations or experiences.

They are described summarily in the following.

2-1-Design earthquake

2-1-1-Risk levels of earthquake and their return period

1-Two risk level mentioned in the following must be considered for seismic design of components of power network system

Risk level 1: Maximum Operational Earthquake (MOE) (occurrence probability 50% during 50 years of assumed useful service)

Risk level 2: Maximum Considerable Earthquake (MCE) (occurrence probability 10% during 50 years of assumed useful service)

2-In Iran, magnitude (magnitude of momentum) and fault distance must be considered on the basis of occurrence probability of MOE and MCE in the facility sites.

1-In this guideline, useful service life of lifelines including desired power facilities is considered relatively around 50 years. Maximum operational earthquake may be occurred once or twice during the service of power facilities. Unacceptable failure modes during operation of facilities are confined to risk level 1 and operation of power system continues reliably. In this risk level, occurrence probability of 50% during 50 years is in accordance with return period of 72 years. In standard no. 2800, overrun probability is considered around 99.5% which gives return period of about 10 years. Maximum earthquake of design is an earthquake with lower occurrence probability and longer return period than to earthquake of MOE. The behavior of power system components in the risk level 2 is in the ultimate mode and the whole system, even if a member is damaged, must maintain its stability. The occurrence probability of 10% for earthquake with higher magnitude during 50 years is in accordance with return period of 475 years.

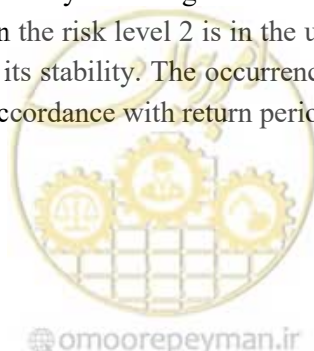

With regard of risk management, overrun probability of 10% has versatile and suitable application in the economic term with consideration of requisite safety. For some structures such as bridges which their life are considered up to about 250 years, this overrun probability in risk gives return period of 2475 years that gives overrun probability of about 2% for structures of useful service life of 50years such as buildings and lifelines that is not economic.

In some fields such as dam construction, the term MCE means Maximum Credible Earthquake. In this guideline, this term is adopted from chapter 12 of ASCE-7-05 and used with the same meaning.

2-For estimation of Permanent Ground Deformation (PGD) due to fault displacement (faulting), liquefaction and landslide, earthquake magnitude M and fault distance R are required. M , R and other related seismic parameters are obtained from analytic or experimental relations resulted from designer desired region risk analysis, especially with regard to its seismicity records.

2-1-2-Seismic design spectra

1-Response spectra of seismic design for power facilities must be computed according to natural period and decay characteristics of structural systems. Also, load due to earthquake must be computed by means of these spectra.

2-Spectrum dynamic analyses for seismic safety control of structural systems must be done by mixing modal spectrum characteristics.

3-One of two following response spectra must be used for designing natural power facilities

A-Acceleration response spectrum for computation of inertia force due to the mass of above ground components

B-Velocity response spectrum for computation of interactional force due to the displacement of soil on the body of buried components

1-In the application these spectra, following notes must be considered:

1-1-In this guideline, elastic response spectrum is used for decay of 5%

1-2-response spectrum for seismic design is obtained from following methods:

A-Site-specific spectra

Site-specific spectra are computed according to seismic activities, active faults and geomorphologic conditions. Regulations of standard no. 2800 are used for obtaining site-specific spectra. Moreover, velocity spectrum must be extracted for buried structures.

B-Probabilistic or deterministic spectra based on record of strong earthquakes

Probabilistic methods have more engineering applications. Spectra from these methods usually have lower values than to their equivalents from deterministic methods.

Generally in determination of design spectra, earthquake occurrence probabilities are considered on the basis of ground strong movements. Deterministic spectra are often used for conservative design and crisis management.

2-Analyse of dynamic response is a method for seismic safety control of structure, especially structures with complex behavior under earthquake. These analyses are expensive and time-consuming and only used when there is difficulty and uncertainty in application of response spectra.

3-Following points must be considered regarding to spectrum

3-1-acceleration response spectrum is used for above-ground structures. Also, these spectra are convenient for systems with several degrees of freedom with application of modal analysis method.

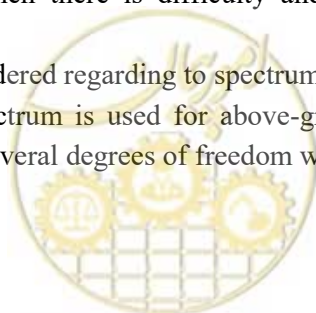

In this guideline, acceleration spectrum available in the valid and current version of standard no. 2800 is used for computations relied on acceleration spectrum.

3-2-Velocity response spectra are used for seismic analysis and design of underground structures such as pipelines, shielded tunnels and underground reservoirs which their action are controlled with seismic behaviors of surrounding soils. Earthquake loading of such structures are done on the basis of displacement response in which, soil deformation in the location of buried structures are computed with usage of velocity response spectrum firstly and then interaction between ground and buried structures is determined by static methods.

3-3-Velocity and acceleration response spectra must be compatible with seismic design of power distribution facilities. In the first version of this guideline, a velocity response is proposed that is nearly compatible with standard no. 2800. For next versions it is required to develop a series of velocity spectrum (as acceleration spectrum in standard no. 2800).

2-1-3-Distribution of seismic intensity in stories

Seismic design intensity of stories is used for power system components located on other facilities or in the upper stories. in stories simplified coefficient distribution (A_i) use for distribution of seismic intensity(K_H), that is given by equation (2-1). This coefficient multiplied at K_H in every stories.

$$A_i = 1 / \sqrt{\frac{H-x}{H}} \quad (2-1)$$

H: Total height of stories

x: the height of stories above the stories of i

Seismic intensity for equipment located on the height over equipment or another structure is a function of seismic intensity on their position. For equipment inside structures, equipment behavior in earthquake will depend on story which is based on it.

2-1-4-Vertical seismic intensity of design

Seismic inputs of vertical direction must be considered for equipment which their behavior is sensitive to the vertical component of earthquake. Vertical seismic intensity of design K_v is given by equation (2-2):

$$K_v = \frac{1}{2} K_H \quad (2-2)$$

Which, K_H is seismic intensity of the design in horizontal direction.

In this guideline for each of components that is presented the chapter 5 and next chapters, their horizontal and vertical earthquakes are computed, appropriately. In almost all of the cases, vertical earthquake is accounted as half of horizontal earthquake.

2-2-Seismic safety control (design methods)

2-2-1-Seismic safety control

Safety of designed equipment must be controlled via following methods:

- 1-Allowable stress design method which must be applied on the risk level 1
- 2-Horizontal force capacity method: this method can be applied for risk level 2 with consideration of maximum lateral forces due to structural deformation in the ultimate mode.

3-Equivalent ductile design method (alternative method) in which the obtained coefficient for earthquake design in risk level 2 is reduced to half of its value and design is performed with allowable stress method.

4-Ductile design method which compare existing ductile ratio of structure with allowable ductile ratio for risk level 2.

Note:

-In the cases which structure is controlled by ductile method, it is required that seismic intensity of 0.3 is controlled with allowable stress.

-In the cases which equipment are of very high importance or certain complexity exists in seismic behavior, convenient dynamic methods are used for control of above mentioned methods according to the design engineer.

1-Generally, allowable stress design method is used in risk level 1 for operation earthquake

2-Horizontal (lateral) force capacity method is one of the control methods. This method has been used in the seismic design of some components of power distribution systems in this guideline and applied appropriately with related details.

3- Equivalent ductile design method (alternative method) is a method in which component stress is computed using one equivalent elastic design spectrum. This spectrum is obtained from multiplication of factor in one spectrum of elastic seismic design. This factor is determined according to ductility coefficient or structures' capacity for absorb energy. In this guideline, this coefficient is considered to be 0.5.

4-The basis of the ductile design method is to give more allowance to structure to absorb more energy (after yield point of material) for more strong earthquake with high acceleration (and velocity) so their components can absorb more strains. Computed ductility coefficient is controlled with formulae of this guideline with appropriate allowable ductility coefficient. Sometimes, ductility coefficient can be described in terms of structural strains.

2-3-Anticipated functions in this guideline

Two functions are considered in this guideline for power system components for given risk levels:

- Unceasing usage function (until before material yield)
 - Risk level 1: designed components must not damage power system function effectively and their function must be continued unceasingly.
- Minimum interruption of function (after material yield)
 - Risk level 2: designed components may inflict drastic physical damage function but without any effect on lives, environment and sustainability of power distribution system. Inflicted damage must be removable as soon as possible and faulted function must be rehabilitated.

In risk level 1, structural members must not be impaired any physical damage that interrupt system usage. This level is called "limit state or mode". In this mode, each building member of system must be in the elastic extent of stress-strain relations and not be reached to yield limit.

In risk level 2, members of structural systems can be physically damaged parochially but systematic and structural sustainability must not be destroyed. This level is called "ultimate state or mode". In this mode, non-elastic deformations (after material yield) may be occurred.

In general, anticipated classification of function in two limit modes has been considered in other codes and guidelines but in detail, they are different. In this guideline, implementation procedure of these limits according to designed components are presented in chapter 5 and afterward chapters based on allowable

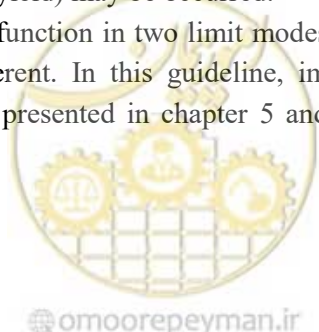

design stress method (for limit mode of damage) and ductile methods of design (for ultimate limit mode) and needed computations and criteria are given.



Chapter 3

Seismic Loading



3-1- Types of Loads

Calculation of loads in gas supply facilities are as follows:

- Dead weight from the equipment and its accessories
- Weight from some materials inside the equipments
- Content's internal pressure (especially in storages, tanks, pipings, and pipeline)
- Water's hydrostatic and hydrodynamic pressures
- Soil's pressure on buried components
- Thermal pressure
- Lateral and vertical pressures caused by earthquake
- Wind's pressure

For types of loads regarding the power supply facility's components, the following considerations are required:

- The wind's pressure is not effective on buried components.
- Unlike buildings, the structures in power facilities do not have any live human loads.
- Components such as tanks, pipelines and inter-facilities pipelines are greatly under the pressure of their internal materials and products.
- Vents and inter-facilities pipings are under high thermal pressures.

3-2- Weights calculations

To calculate the materials unit weight and different loads, sixth chapter of national buildings regulations should be used.

3-3- Loads combination

In this guideline, regarding each equipment, the implemented loads and their combinations are presented from chapter 5 forward.

3-4- Types of equipments by their location

The power supply facilities are generally located as follows:

- Aerial equipments
- On-ground equipments
- Underground and buried equipments

3-5- Seismic loads calculation methods

Earthquake-imposed loads on power supply facilities are implemented as follows:

- 1- The inertial force caused by the equipments' mass which their movement is not constrained in soil. This force, generally, is created and calculated in aerial and on-ground structures.
- 2- The force from the bed soil's displacement which is imposed on the buried structures. In this case, the soil displacement is multiplied to the spring constant between soil and building and imposes its

force on the equipment.

- 3- In some cases for the buried structures which their mass and their internal materials could create inertia due to earthquakes, both the inertia and the force from displacement should be considered.

3-6-The effects of earthquake on power supply facilities

The effects of earthquakes on power supply facilities could be divided into two effects and then perform the seismic loading calculations from each one:

- 1- The dynamic effect of earthquake caused by soil vibrations (seismic waves propagation in soil) which results in the three following responses:
 - a. Acceleration
 - b. Velocity
 - c. Displacement (causes serious damages in all structures, especially in the buried lines).
- 2- The static effect or the so-called geotechnical hazards which results in permanent displacements in soil, including:
 - a. Liquefaction
 - b. Earthquake
 - c. Fault

3-7-The method of imposing earthquake effects on power equipments

- 1- In order to calculate the imposed load on aerial and on-ground components, the inertia force caused by the earthquake acceleration's effect on the equipment mass must be calculated. In this method, the acceleration spectrum is used in conformity with the regulations of the 2800 standard.
- 2- In order to calculate the inertia force caused by the effect of acceleration, the "pseudo-static method" is used. In cases where the equipment's period is long and/or complicated (when the structure's first vibration mode is not predominant), the "modified pseudo-static method" is applied.
- 3- In order to calculate the forced from the earth displacement on buried structures, the "displacement response method" is used. In this method, after calculating the earth's displacement in desired points, the imposed force on the structure is calculated by determining the spring constant of soil surrounding the structure.
- 4- In the displacement response method, calculating the soil's strain surrounding the structure, the buried structure's strain could be calculated from the soil's strain, considering the adhesion between the buried structure and its surrounding soil.



3-7-1- importance factor

The structure's importance factor is denoted by β_1 based on its importance and is determined using table 3.2.

Table 3.1: Importance factor, β_1

| Importance category | Very high | High | Medium | Low |
|---------------------|-----------|------|--------|-----|
| β_1 | 1.4 | 1.2 | 1 | 0.8 |

The need for immediate occupancy of under design components and the necessity for their post-earthquake safety play a significant role in raising the importance factor of that component in power supply system. The definition for different categories in table 3.3 and also the importance classification of different equipments are presented in table 3.4.

In cases in which two importance levels are presumed, the employer's judgment determines the final importance level.

Table 3.2: Definitions for different importance categories

| Importance | Description |
|------------|--|
| Very high | Components which their destruction causes vast casualties and financial losses and damages equipments and environment. As well as components which halting their performance would lead to secondary lives, financial and environmental damages. |
| High | Components which their destruction would lead to gas supply cut or lives, financial, and environmental losses and damages. |
| Medium | Components which their destruction would lead to interruptions in power supply. |
| Low | Components which their destruction do not have any considerable effect on power supply system and would not lead to casualty and financial and environmental damages. |

Table 3.3: Classification the importance of facilities

| Equipments | | Very high | high | Medium | Low |
|-----------------------------------|-----------------------------|-----------|------|--------|-----|
| Power plant equipments | Boiler and its appurtenance | | | × | |
| | Turbine & Appurtenance | | | × | |
| | Crane | | | × | |
| | Stack | | | × | |
| Control Unit and safekeeping | | | × | × | |
| Petroleum Fuel Reservoirs | | | | × | |
| Gas Fuel Tanks | | × | × | × | × |
| power plant seismic equipments | | × | × | × | × |
| Substation equipments | transformer | × | × | | |
| | insulator | × | × | | |
| | bushing | × | × | | |
| | cable | × | × | | |
| | Other equipment | × | × | | |
| Distribution and transition lines | | | × | × | |

3-7-2- Design base acceleration ratio

Design base acceleration ratio, β_2 , can be defined from table 3-2 considering the location of construction based on standard 2800.

Table3-4 Design Base Acceleration Ratio (β_2)

| Seismicity Status | 1 (Very High) | 2 (High) | 3 (Medium) | 4 (Low) |
|-------------------|------------------|-------------|---------------|------------|
| β_2 | 0.35 | 0.30 | 0.25 | 0.20 |

3-7-3- Amplification factor from the bedrock to ground level due to soil type and zone factor

Magnitude of the earthquake force is related to soil layers amplification of the location. Amplification factor based on soil layers is labeled as β_3 . Table 3-3 shows amplification factor for all types of grounds.

Table 3-5 site magnification factor (β_3)

| Design base acceleration ratio | Soil Type | | | |
|-----------------------------------|-----------|--------|--------|--------|
| | Type 1 | Type 2 | Type 3 | Type 4 |
| Low | 1.5 | 1.5 | 1.75 | 2.25 |
| Medium | 1.5 | 1.5 | 1.75 | 2.25 |
| High | 1.5 | 1.5 | 1.75 | 1.75 |
| Very High | 1.5 | 1.5 | 1.75 | 1.75 |

3-7-4- Earthquake Factor

3-7-4-1- Design horizontal seismic coefficient

Design horizontal seismic coefficient, K_{SH} , can be calculated by (3-3):

$$K_{SH} = \beta_4 K_H \geq 0.2 \quad (3-1)$$

K_{SH} : Design horizontal seismic coefficient (considering structure frequency response)

β_4 : Horizontal response magnification factor, value of this factor is function of structure height from the earth.

- $\beta_4 = 1.0$ for height less than or equal to 16 meters.
- $\beta_4 = 0.0125h + 0.8$ for height between 16 meters and 35 meters.
- $\beta_4 = 1.2375$ for height more than 35 meters (Period control is necessary for the pseudo-static method at height more than 35 meters)
- h: height from the earth level (meter)

3-7-4-2- Design horizontal earthquake load

F_{SH} , Design horizontal earthquake load (static load equivalent) could be extracted from equation (3-2):

$$F_{SH} = K_{SH} W_H \quad (3-2)$$

F_{SH} : Design horizontal earthquake load (N)

W_H : Structure weight + live and dead load (N)

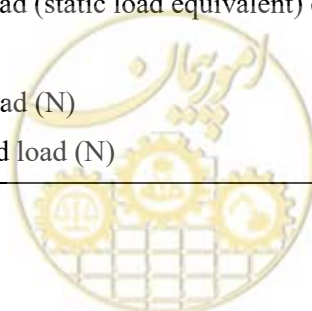

3-7-5-1- modified pseudo-static method

For structures with normal or low importance and longer periods than those in the section 3-1-5, modified pseudo-static method would be used.

After calculating the seismic coefficient from modified pseudo-static method, to determine the vertical or horizontal earthquake load, we should multiple it to structure (equipment) weight.

3-7-5-2-Modified seismic coefficient

Modified seismic coefficient in two horizontal and vertical directions can be gained from horizontal and vertical seismic intensity:

$$K_{MH} = \beta_5 K_H \quad (3-3)$$

K_{MH} : Horizontal modified seismic coefficient

β_5 : Amplification factor

$$K_H = 0.3 \cdot \beta_0 \cdot \beta_1 \cdot \beta_2 \cdot \beta_3 \quad (3-4)$$

3-7-5-3- Vertical modified seismic coefficient

$$K_{MV} = \beta_6 K_V \quad (3-5)$$

K_{MV} : Vertical modified seismic coefficient

3-7-6- Dynamic Methods

In this method, the mathematical model of equipment is exposed to spectral and/or time-history loading, and is solved by solving the dynamic balance equations. Usually, the dynamic method is used for controlling the static or pseudo-dynamic methods and/or analyzing very important or complex structures.

3-7-6-1- Response Spectrum Method

Horizontal response acceleration for each mode $A_H(T)$ can be extracted from equation 3-6:

$$A_H(T) = \beta_5 \cdot \alpha_H \quad (3-6)$$

$A_H(T)$: Horizontal response acceleration in natural period T (cm/s^2)

β_5 : Horizontal response magnification factor ($\beta_5 = 1.5$ for periods less than 0.3 sec and $\beta_5 = 0.75$ for periods more than 0.3 sec)

α_H : Horizontal acceleration on the ground level (cm/s^2) obtained from equation 3-7:

$$\alpha_H = 700 \cdot \beta_1 \cdot \beta_2 \cdot \beta_3 \quad (3-7)$$

Also vertical response acceleration for each mode $A_V(T)$ can be extracted from equation 3-8:

$$A_V(T) = \beta_6 \cdot \alpha_V \quad (3-8)$$

$A_V(T)$: Vertical response acceleration in natural period T (cm/s^2)

β_6 : Vertical response magnification factor ($\beta_6 = 1.5$ for domain base towers and $\beta_6 = 2$ for other sizes)

α_V : Horizontal acceleration on the ground level (cm/s^2) obtained from equation 3-9:

$$\alpha_V = 350 \cdot \beta_1 \cdot \beta_2 \cdot \beta_3 \quad (3-9)$$

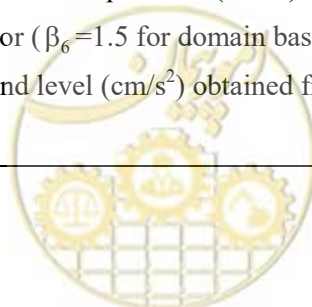

3-7-6-2- Time history analysis method

In Time history analysis method, an appropriate accelerometer should be chosen then its maximum horizontal acceleration based on the location can be extracted from one of following methods:

1- If records of the ground level are available:

$$\alpha'_{HT} = 700 \cdot \beta_1 \cdot \beta_2 \quad (3-10)$$

α'_{HT} : Maximum horizontal acceleration in the ground level (cm/s²)

2- If records of the ground surface are available

$$\alpha'_H = \alpha_H = 700 \cdot \beta_1 \cdot \beta_2 \cdot \beta_3 \quad (3-11)$$

α_H : Horizontal acceleration in the ground level in spectrum analysis (cm/s²)

α'_H : Maximum horizontal acceleration in the ground level in the Time history analysis

3-7-6-3-Displacement response method (for buried structures)

This method is devised based on beam on an elastic bed theory. In this method, using the earthquake velocity response spectrum and considering the first mode of shear vibration of soil, the displacement is calculated and according to the soil's resilience is transformed to the effective force on the structure.

In the next chapter, the seismic loading of each equipment is presented using the above-mentioned methods.

3-8-Loading caused by earthquake's geotechnical hazards on equipments

In addition to the earth's vibrations during earthquake, the equipments must be safe against geotechnical hazards caused by earthquake. The most important of which are liquefaction (and lateral spreading), landslide, and faulting.

3-8-1-Liquefaction

Even though there is low potential for liquefaction in Iran, in seaside, riversides, and in regions with fine-grained sandy texture along with high underground water level, this hazard threatens different equipments, especially the buried types.

- Seismic design against liquefaction must be carried out by examining the seismic performance caused by permanent displacement of earth from liquefaction and considering the soil's conditions.
- Regions with need of seismic design against liquefaction must be selected based on geology and geomorphology, ground situation, and gas facilities installation position.

The earth permanent displacement caused by liquefaction should be considered as follows.

- Horizontal displacement caused by lateral spreading on sloped surfaces of ground
- Horizontal displacement caused by earth lateral spreading in seaside regions
- Ground settlement

The effect of liquefaction is measured as vertical and horizontal displacements and is applied consistent with the given distribution on the buried structure.

If gas facilities such as pipelines are installed on structures, there would be no need to consider the ground settlement.

3-8-2-Landslide

In mountains regions with high ground slope and weak layers, there is a possibility for landslides and may

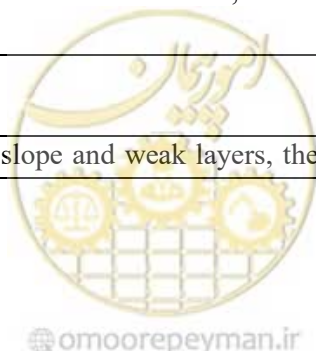

cause damages to different gas equipments.

In order to prevent the landslide hazard caused by permanent ground displacement (PGD), the evaluation must be carried out based on the following steps:

- Evaluation of the ground susceptibility to landslides.
- Evaluating the potential for triggering landslides and slope deformation.
- Evaluating the probability of landslide and slope deformation occurrence.
- Evaluating hazards resulted from landslides and slope deformation

3-8-3-Faulting

It is impossible to avoid regions with faulting potential in gas supply systems. Therefore, the effects caused by displacement of active faults which structures of this system are installed through them, should be considered as far as possible.

- Existence of the active fault shall be determined by the specific geological features of the active fault shape.
- Area through which it is possible to cross an active fault should be confirmed by geological survey, geophysical explorations, boring explorations, and trench survey.
- Whenever gas facilities cross an active fault, they should be designed considering the permanent ground displacement from faulting in order to realize the seismic performance.
- Whenever the effect of faulting becomes visible on ground surface, the gas facilities should be seismic designed for faulting.

Chapter 3 of vital vessels indicates how to calculate and apply loads caused by seismic geotechnical hazards.

3-9-Soil classification

For simpler use of 2800-standard equations, the same soil classification is used as in this standard.



Chapter 4

SEIMIC DESIGN & SAFETY CONTROL METHOD



4-1- Seismic Design

4-1-1- General

Seismic design of the power system equipment is based on the site conditions as well as the structural characteristics of the facility, and through the methods explained in this manual.

The seismic design of the power system components aims to keep the materials behavior within the elastic range and keep the system operating in level-1 operation earthquakes. In the advent of level-2 earthquakes, although the materials behavior goes beyond the elastic range, their ductility shall be limited so that no breakage happens and the limited potential failures can be resolved quickly (through emergency repairs).

The failures are divided in three categories.

- Physical failures, in which the component is considerably deformed, but no cracks occur to affect the performance (damage).
- Functional failure, in which cracks or breaks result in content leakage, short circuit, or similar problems, which interfere with the system performance (failure).
- System failure, in which due to the large scale of the damages or functional failures operation is unsafe and the system shall stop immediately (instability).

4-2- Principals of Seismic Design

Power system components, depending on the risk level, are designed through either allowable stress analysis (elastic behavior) method, or ductility (plastic behavior) method.

Allowable stress analysis method is used for level-1 risks.

When concerning level-2 risks, the seismic design is performed through the ductility method.

- When concerning level-2 risks, the ductility method is used.
- In allowable stress analysis method, the stress generated in components must not exceed the allowable quantities; otherwise non-restorable deformations can remain in the components after the earthquake.
- In ductility design method, the plastic deformations that take place in the components must be smaller than the allowable quantities. In this case, performance of the facilities is not bothered during and after the earthquake.

4-2-1- Seismic Design through Allowable Stress

4-2-1-1- Stress Calculation

The ultimate stress is calculated through combining stresses generated by various loads.

4-2-1-2- Allowable Stresses in Seismic Analysis

Allowable stress of the materials is defined based on the type of facility and its location.

4-2-1-3- Stress Calculation Evaluation

A structure is analytically acceptable, when all the calculated stress are smaller than the allowable

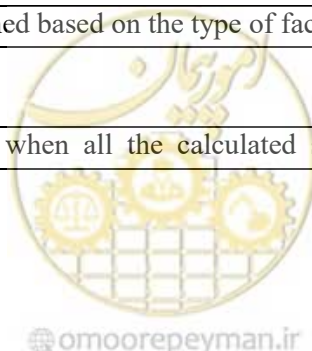

quantities.

4-2-2- How to perform seismic analysis for ductility method

4-2-2-1- Ductility design method

The procedure of seismic design evaluation by the ductility method is used for earthquake hazard level-2.

4-2-2-2-Seismic response analysis method

The elastoplasts deformations in each point of structure could be obtained by response analysis under effect of earthquake.

For seismic design of the structures, plastic deformations can be figured out through response analysis in one of the following methods.

1- Ultimate plastic deformation design

In structures, where the first mode of vibration is dominant, plastic deformation ratio can be worked out through applying constant energy rule to the failure mode.

1-1- Modified design seismic coefficient

The modified design seismic coefficient is calculated considering discussions of Chapter 3.

1-2- Plastic response ductility coefficient

Plastic response ductility coefficient μ_p of the defected component can be calculated through

Equation (4-1).

$$\mu_p = \frac{1}{4C} \left\{ \left(\frac{K_{MH}}{K_y} \right)^2 - 1 \right\} \quad (4-1)$$

μ_p : Ductility coefficient of the defected component; if $K_y \geq K_{MH}$, then $\mu_p = 0$.

K_{MH} : Modified horizontal seismic coefficient related to the target structure.

y: Horizontal seismic coefficient at the beginning of the defected component.

C: The coefficient which depends on the hysteresis behavior of the component while absorbing the energy and tending to the failure as follows:

C=2n if the characteristics of the hysteresis is completely elastoplastic.

C=1n if the characteristics of the hysteresis is of slipping type.

n is the number of appropriate cycles in the related hysteresis curve. When the number of cycles cannot be determined through detailed equations, the value is conservatively assumed 1.

In this case the vertical seismic coefficient must be considered under the worst conditions.

1-3- Plastic deformation estimation

In ductility design method Equation 4-2 must apply:

$$\mu_p \leq \mu_{pa} \quad (4-2)$$

μ_p : Ductility coefficient of the exposed component

μ_{pa} : Allowable ductility coefficient



2-Yield strength design method (for frame structures)

For frames, the design is performed through ductility method using yield strength.

2-1- Modified design seismic coefficient

This coefficient is calculated through the modified equivalent static method as defined in Chapter 3.

2-2- Structural characteristic coefficient

Structural characteristic coefficient D_S is calculated through Equation (4-3), or borrowed from the other codes. D_S ranges between 0.25 and 0.5.

$$D_S = \frac{1}{\sqrt{1 + 4C\mu_{pa}}} \quad (4-3)$$

D_S : Structural characteristic coefficient (almost opposite of the behavior coefficient R of the structures in standard 2800)

2-3- Seismic Capacity

Seismic capacity Q_u is calculated through Equation (4-4).

$$Q_u = K_y W_0 \quad (4-4)$$

K_y : Yield horizontal seismic coefficient at the beginning of the exposed component.

In this case the vertical seismic coefficient must be considered under the most unfavorable conditions.

W_0 : Operation weight of the target structure

4-2- Required seismic capacity

The required seismic coefficient is calculated through Equation (5-4):

$$Q_{un} = D_S K_{MH} W_0 \quad (4-5)$$

Q_{un} : Required seismic coefficient

D_S : Structural characteristic coefficient calculated in (B)

K_{MH} : Modified horizontal seismic coefficient

W_0 : Operational weight of the structure

2-5- Required seismic coefficient estimation

Required seismic coefficient Q_{un} shall not exceed the seismic capacity Q_u .

3-Linear modal response analysis

For nonlinear components, which exceed the flowing capacity, the linear response analysis is performed based on reducing the rigidity from elastic rigidity (depending on the degree of being non-linear and equivalent damping factor).

Linear modal response analysis is performed using acceleration response analysis based on steps 3-1 to 3-6 defined below:

3-1- Design horizontal and vertical acceleration spectra is calculated through Equations (4-6) and (4-7).

$$A_H^{(i)} = 350\beta_1\beta_2\beta_5 \quad (4-6)$$

$$A_V^{(i)} = 175\beta_1\beta_2\beta_6 \quad (4-7)$$

$A_H(i)$: Design horizontal response acceleration of it mode of vibration (cm/s^2)

$A_V(i)$: Design vertical response acceleration of eath mode of vibration (cm/s^2)

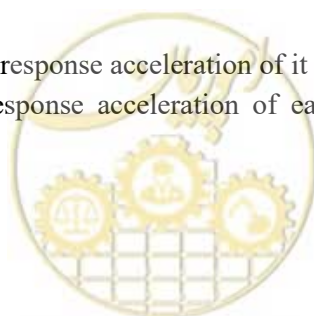

- β1: Significant factor taken from Table (3-1)
 - β2: Design acceleration ration taken from Table (3-4)
 - β5: Magnification factor of the horizontal response (to simplify the calculation and conservatively assumed 0.75 for periods longer than 0.3s and 1.5 for periods shorter than 0.3s)
- 3-2- Component rigidity must reduce based on the structure being non-linear.
- 3-3- Equivalent damping factor related to the ductile buckling energy is calculated through non-linear analysis of the structure.
- 3-4- Response values of R such as the shearing force, moment, acceleration and displacements required for designing each vibration mode, is calculated using square root of the sum of squares.

$$R = \sqrt{\sum_i R_i^2} \quad (4-8)$$

Where R_i is the quantity of the response of i^{th} mode.

- 3-5- Response displacement should be calculated using the quantity of the component's response.
- 3-6- Make sure that the ductility coefficient, which is calculated through “e” does not exceed the ductility coefficient.
- 4-Non-linear time history response analysis
- Time history response analysis is performed as follows:
- 4-1- Characteristics of load-displacement of the structure must be based on non-linear hysteric model, and the results related to each target period are obtained directly through time history analysis.
- 4-2- Applying the earthquake wave with maximum acceleration to the target point
- 4-3- Ductility coefficient is calculated through displacement of the component.
- 4-4- The calculated ductility coefficient shall not exceed the allowable ductility coefficient.
- 5-Displacement response coefficient

This method includes steps (5-1) to (5-4) as explained bellow:

- 5-1- Displacement of the point with certain displacement, is the response displacement of the supports, or displacement of foundation due to the ground movements.
- 5-2- Displacement of the component is calculated through static analysis of the model, using non-linear load-displacement equation.
- 5-3- Ductility coefficient is calculated using the results of the component deformation.
- 5-4- Ductility coefficient shall not exceed the allowable plastic deformation ratio.

4-2-2-3- Ductility coefficient

Ductility coefficient is calculated through plastic deformation of the seismic analysis of the failure mode.

4-2-2-4- Allowable ductility coefficient

Allowable ductility coefficient of the component is determined based on the characteristics of the elastoplastic behaviors, such as fatigue and buckling under constant loading, and depending on the mode of the seismic failure in the target components.

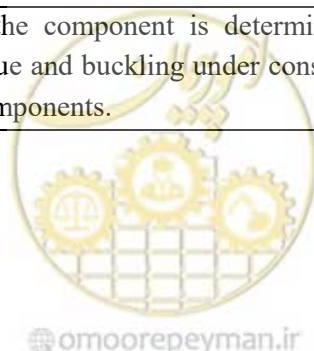

4-2-2-5- Ductility coefficient estimation

When the allowable ductility coefficient of all the important components is equal to or bigger than the target ductility coefficient, the seismic performance is acceptable.

4-3- Characteristics of the materials in allowable stress method

1-Concrete building

1-1-Minimum compressive strength required for concrete is:

- For precast pipe support (pipe mesh): $f_c \geq 25 \text{ N/mm}^2$ (3500p.s.i)
- For structures, foundations, floorings, and other structure works:
 $f_c \geq 21.1 \text{ N/mm}^2$ (3000p.s.i)
- For fire rated components and channels: $f_c \geq 18 \text{ N/mm}^2$ (2500p.s.i)
- For Meager concrete: $f_c \geq 8.0 \text{ N/mm}^2$ (1100p.s.i)

When the concrete contains anti sulfate cement, the cement density must not be less than 310kg/m³. For other types of cement, the density must not be less than 310kg/m³.

1-2-Reinforcement steel

a) Rebar

The rebar must be of grade 60 (with minimum flowing strength of $f_y=414 \text{ N/mm}^2$) according to ASTM615 or similar materials.

b) Bars

Bars must be of grade 40 (with minimum flowing strength of $f=276 \text{ N/mm}^2$) according to ASTM615 or similar materials.

c) Welded steel meshes

Welded steel meshes must be of grade 70 (with minimum flowing strength of 485 N/mm^2) according to ASTM, A496, and A497 or similar materials.

1-3-Anchors, sheets, and other steel materials used in concrete

Required materials for anchors, sheets, and other steel materials used in concrete must be of ASTM A36 type, and can be welded according to ASTM standards or similar materials.

1-4-Allowable stresses

Allowable stresses for concrete and steel must be selected in accordance with Chapter 9 of Iran's national construction regulations, and Iran's concrete code (ABA).

1-5-Allowable uplifts and deformations

Allowable uplift of the concrete components must comply with the national construction regulations and Iran's concrete code.

2-Steel structures

2-1-Materials

- Material must comply with ASTM A36 or similar standards

2-2-Bolts

- Bolts used in the joints must comply with ASTM A325 or similar standards
- Bolts used in the secondary joints must comply with ASTM A307 Grade A or similar standards.
- Normal and heavy duty nuts must comply with ASTM A563 or similar standards.



- Gaskets must comply with ASTM F436 or similar standards.



Chapter 5

Seismic Design and Safety Control of Power Plant Equipment



5-1- Power Plant Equipment

Equipment discussed in this chapter includes:

- 1-Boiler and its appurtenance
- 2-Turbine and its appurtenance
- 3-Crane
- 4-Stack (and cooling tower)
- 5-Control unit

Petroleum fuel reservoirs, gas, and power plant piping system are discussed in chapters 6, 7, and 8.

5-2- Performance Level

5-2-1- Boiler & its Appurtenance

Boiler and its appurtenance must be designed to keep operating non-stop under level-1 risk conditions, and be able to restart immediately after a minimum stoppage under level-2 risk conditions.

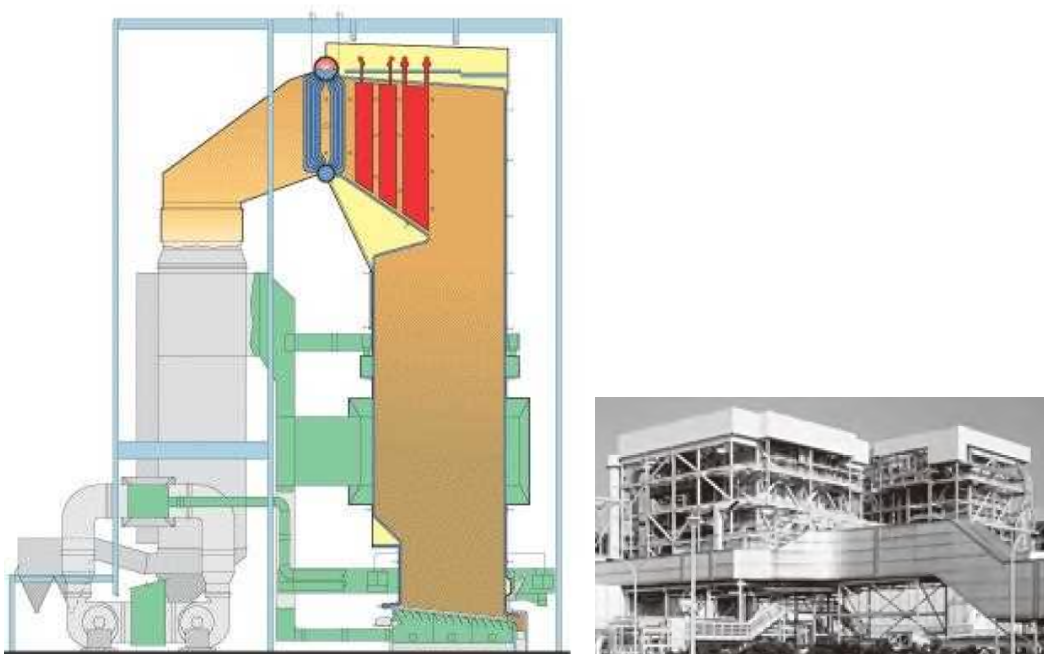

Figure 5-1: Boiler & its Appurtenance

5-2-2- Steam Turbine & its Appurtenance

The turbine and its appurtenance are expected to keep operating non-stop under the level-1 risk conditions. In occasions of level-2 earthquakes, the allowable defects shall be so that the turbine can start to work after short partial repairs. Seismic behavior of the rotating machines must be so that it can stop safely.





Figure 5-2: Steam Turbine

5-2-3- Stack

The stack is required to keep operating non-stop under level-1 risk conditions. Under level-2 risk conditions, the stack is expected to start to work immediately and after partial repairs.

5-2-4- Control Unit

The control unit system must be capable of operating in occasions of the earthquake, and shall not let the operation fail. It is expected to keep operating non-stop under level-1 risk conditions and with minimum stoppage under level-2 risk conditions.

Considering the regulations of seismic design, control and safety units not only shall be protected against the defects, but also shall keep operating normally in occasions of any sorts of earthquakes.

Seismic design criteria must be specifically taken into consideration in design of control and safety equipment, maintenance, and provision of general safety in order to secure the performance.

From the perspective of power supply, since stoppage of control and safety systems is not allowed, main body equipment must remain in the best possible conditions in occasions of destruction.

5-3- Seismic Design of Boiler & its Appurtenance

5-3-1- Mounting Procedure

Seismic mounting of boiler and its appurtenance must be based on Table (5-1).

| Appurtenance | Seismic Mounting Method | | |
|--|--------------------------|------------------------------------|-------------------------|
| | Equivalent static Method | Corrected Equivalent static Method | Dynamic Analysis Method |
| Boiler Main Body | ○ | | |
| Boiler Support Frame | ○ | ○ | ○ |
| Boiler Main Appurtenance | ○ | | |
| Air/Smoke Duct and Exhaust Gas Equipment | ○ | | |

Proper seismic design method is marked by ○. Any other methods that can guarantee the safety can be used.

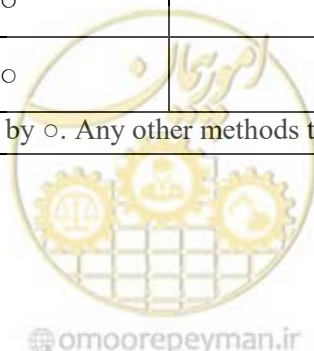

For the support frame of the boilers with height of less than 30 meters, equivalent static method is used. For support frame of the boilers with height of 30-60 meters, the corrected equivalent static method is used. And, for the support frame of the boilers with height of more than 60 meters, the dynamic method is used.

5-3-2- Calculation Procedure

5-3-2-1- Boiler Main Body

- 1-Boiler main bodies are categorized as boiler restrained from the bottom, self-support boilers, and other boilers with similar support behaviors.
- 2-In all types of boiler body; the seismic forces must be easily transmitted to the support structure or the foundation.
- 3-Dead load of the boiler main body includes weight of the furnace wall, internal tube, reservoir with external shores, piping, the liquid content, and the other loads.
- 4-The Seismic force in this case must be calculated through Equation (5-1).

$$F=KSH \times W \quad (5-1)$$

F: Seismic force related to the part of structure above the ground (N)
 W: Force caused by the dead loads (N)
 KSH: Design coefficient of horizontal earthquake

To calculate the design coefficient of earthquake, average rate of significance can be considered for the boiler.

The following points require excessive attention in seismic design of various types of boilers:

- 1-The furnace wall of the main body would not be destructed, unless the required strength is not provided at the support points; because the nature of the structure is considerably rigid.
 - 1-1 Boilers with halter are clustered vertically by halter to the support frame. Since the furnace wall is reinforced by clamps it can be considered as a highly rigid beam on several supports. Therefore, its natural frequency is relatively more than that of the frame, and resonances are less likely to happen in it.
 - 1-2-Self-support boiler is also short, box-like, and therefore relatively rigid. The boiler safety is provided through designing a support structure against vibrations, and side movements.
- 2-In boilers with halter, the seismic design covers specifically the seismic strength of the cluster and strength of the environmental elements.
- 3-The following issues must be taken into consideration in seismic design of the boilers with halter:
 - 3-1-Since the seismic force caused by the mass of the furnace wall is transmitted through the clamps and clusters to the frame, absorption of the expansive deformation (thermal expansion) during the operation must be taken into consideration.
 - 3-2-The horizontal seismic force imposed on the internal tube is transmitted to the fix furnace and the frame. Since the pipes are likely to hit the furnace wall, in order to prevent any sorts of breakage, all the points of intersection must be straight.
 - 3-3-Regarding the massive structures, like the steel tank and the water tank, the clamps must be capable of absorbing the expansive deformation easily during the operation, and transmit the horizontal seismic force to the frame.



5-3-2-2- Support Frame for Boiler

The following issues must be taken into consideration while designing support frame for the boiler:

The dead load includes weight of the frame and weight of the boiler

The live load includes the equipment affixed en situ.

The natural period T is measured by seconds, and is calculated through the following equation for designing the frame:

$$T=0.02H \quad H < 16 \quad (5-1)$$

H : Height of the building (m)

$$T = (0.02 + 0.01\alpha) \cdot H \quad H \geq 16 \quad (5-2)$$

α : Ratio of the height of the steel floors to the total height of the building.

Spectrum method or time history method is used in dynamic analysis. The weight referred to in the dynamic analysis is the effective weight of the structure, which includes the weight of the dead loads. After calculating weight of the boiler, the piping, and the channels, the effective weight can be calculated.

Seismic design of the support frame for boiler is similar to that of the buildings. First of all the seismic response of the structure is simulated using the specifications of the frame mass-string model, in which the excessive mass is the main body of the boiler. However, since in this method, form of the support frame, on which the main body on the boiler is hanging, is not taken into consideration, it is better to use the dynamic analysis method for seismic design. Figure (5-1) shows an example of modeling the boiler frame.

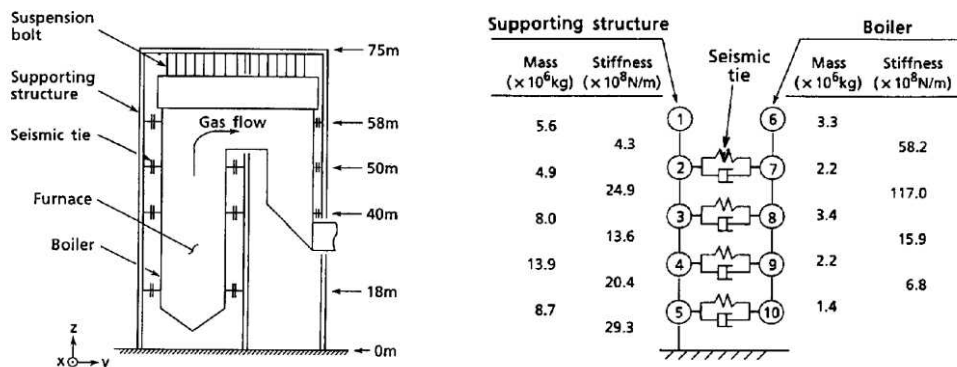

Figure 5-3: Modeling the Boiler Frame

5-3-2-3- Main Appurtenance of the Boiler

1-Structural form and static conditions of the main appurtenance must be considered in the seismic design.

2-The operation dead load includes weight of the equipment, weight of the thermal insulation, and weight of the fluid content.

1-Boiler appurtenances are categorized structurally as:

- 1-1-Air preheated
- 1-2-Ductilation (blowing machine)
- 1-3-Pump
- 1-4-Air compressor
- 1-5-Heatexchanger, towers, and reservoir



- 2-Due to the relatively high rigidity and seismic strength of the appurtenance, it would be enough to check the strength of their joints to the body. To do this, the stresses imposed on the joints of these appurtenances must be smaller than their allowable stress.

5-3-2-4- Smoke & Air Ducts and Gas Filtration Equipment

Design of smoke & air ducts and gas filtration equipment shall be based on the following issues:

- 1-The dead load includes the dead weight of the main body and weight of its thermal insulation.
- 2-Seismic force is calculated through the static method.
- 3-Support frame in this case is designed like the support frame of the boiler.

1-Considerations related to seismic design of the smoke & air ducts and gas filtration equipment are as follows.

1-1-Smoke duct is a channel for passage of the exhaust gas made by the combustion in the boiler. It is usually located between the outlet of the fuel optimizer and the stack mouth. Therefore, the smoke duct behind the heat exchanger of the boiler must be designed like the equipment.

The air duct is indeed an air inlet for the combustion in the boiler. It is usually located between the compressed air intake fan and the air inlet.

Seismic design of the smoke duct is based on examining the strength of the cluster elements and support bases of the duct. This design does not cover the structural elements, like the internal posts of the smoke duct.

1-2-The main body of the dust filter is rigid and has a structure that transmits the seismic forces easily to the support frame. Therefore only the strength of its support frame is measured.

1-3-Main body of the exhaust gas digitizer is a combination of steel and steel sheet, and the main body is expected to be strong enough against the operation internal pressure. Therefore seismic design of the structure is based on studying the strength of elements like the support structure elements.

2-Since the air & smoke duct is a relatively simple structure and is set up at low heights, the main method of seismic design is the static method.

3-The following issues must be taken into consideration in seismic design of the exhaust gas digitizer:

3-1-The unit must be capable of transmitting the seismic forces easily to the support frame or the foundation.

3-2-Considering the fact that the frame would get as hot as the gas, the unit must be capable of absorbing the resulted expansion.

4-Calculating the design load

4-1-Weight of the entire appurtenance, including the stairs, piping, dust filter and its tank, digitizer, and sulfur remover, must be taken into consideration.

4-2-Weight of the main body of the air & smoke duct shall include weight of the stuck dust.

5-Evaluation and calculation of stress

5-1-Since the air & smoke duct is empty and has a large section compared to its weight, the impact of wind on it is bigger than that of the earthquake.

5-2-In the exhaust air digitizer, the allowable stress of the materials must be corrected considering the high temperature of the exhaust gas. To do this, the allowable tension must be the minimum value of $0.6S_{u0}$, $0.6S_u$, $0.9S_{y0}$ or S_y , where S_u is the tensile strength of temperature at the operation temperature of $0 - 40^\circ\text{C}$, which must be less than the minimum value of the standard

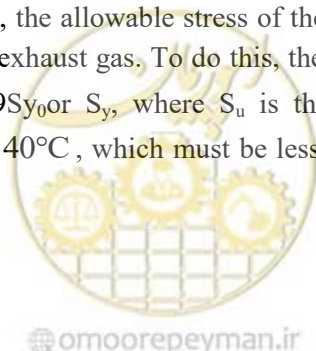

material. S_{u0} is the tensile strength at the surrounding temperature. S_y is the yield strength in the operation temperature, and S_{y0} is the yield temperature in the surrounding temperature.

5-3-3- Allowable Values

Allowable stress of the boiler structure and its appurtenance is calculated through the paragraph related to the steel materials in Chapter-4.

5-3-4- Judgment Criterion

The stress caused by the design seismic force must be smaller than the allowable stress.

5-4-Seismic Design Calculations for Turbine & Appurtenance

5-4-1- Mounting Procedure

The procedure of seismic mounting on the turbine and its appurtenance would be as follows:

- 1-Equivalent static methods, corrected static methods, dynamic methods, and physical & laboratory modeling can be used for mounting the turbine and its appurtenance.
- 2-Seismic design basically includes evaluation of deformations, defects, and movements caused by the seismic force and the obliged relocations.

Turbine refers to both gas turbine and steam turbine in this article.

5-4-2- Calculation Procedure

5-4-2-1- Main Body of the Turbine

The following issues shall be taken into construction in the seismic design of the body of the turbine:

- 1-The seismic design of the body of the turbine and motor oil equipment is expected to provide non-stop operation.
- 2-Seismic design of the main body of the turbine (anchor bolt, fixing lever, etc.) must include the equipment fixed on the body and the foundation.
- 3-Design of the anchor bolts and fixing lever must comply with the regulations.
 - 3-1-Support instruments including anchor bolts must be designed.
 - 3-2-At least one of the emergency oil pump power outlets, oil pump gear convertor, and emergency gear of the oil pump shall never fail.

Oil splashes caused by vibration of the oil must not happen during the earthquake. To ensure this, ASTM D445 standards or other approved standards must be observed.

The steam turbine is extremely rigid and is safe enough against fluctuations. Therefore it can be considered a solid object in the seismic design. Therefore, under the normal conditions, the strength against the relocation caused by the seismic design must be taken into consideration.

The motor oil mounting equipment is highly rigid and safe against the earthquake. Therefore due to the high seismic strength against the deformation caused by the seismic relocation, the seismic design of the below elements and their supports, including the anchor bolts, is required:

- The main reservoir
- Motor oil cooler

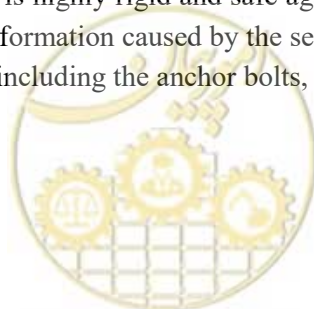

- Emergency oil pump
- Oil pump gear convertor
- Oil pump emergency gear

5-4-2-2- Generator and its Appurtenance

- 1-Generator and its appurtenance shall be designed to remain intact in the adduct of earthquakes.
- 2-Seismic design of fixing tools (anchor bolts and levers) attached to the main body of the generator is required.
- 3-Regarding the appurtenance, seismic design of the following supports is required:
 - 3-1-Motor oil equipment and oil insulation
 - 3-2-Hydrogen and carbon dioxide processing equipment
 - 3-3-The main bus between the generator and the main transformer and the appurtenance
 - 3-4-The main transformer

- 1-Due to the high vibration frequency of the generator, it exhibits rather a rigid behavior and is not likely to fail in the advent of earthquake. Therefore, only the upturning moment and the shearing force at the main body and the foundation (for example the anchor bolt and lever) must be examined. To do this, the seismic force is calculated through Equation (5-1) and using weight of the generator. The incoming stresses and the upturning moment caused by this force must not exceed the allowable stress and the resistant upturning moment.
- 2-The continuance driving of the seal oil equipment is required in the generator of the hydrogen gas cooling to avoid the leakage of the hydrogen gas from the bearing even during the earthquake.
- 3-Because the rigidity of the equipment that composes these facilities is high, only the study of the supporting material like the anchor bolt etc. about the following device should be performed.
 - Vacuum chamber
 - Expansion tank
 - Air extraction tank
 - Piping

5-4-2-3- Condenser

- 1-The stress and overturning moment caused by the earthquake, which is calculated through Equation (5-1) at a fixed part with the foundation shall not exceed the allowable tension and the resistant overturning moment.
- 2-The stress caused by the earthquake, which is calculated through Equation (5-1) at the condenser-turbine connection shall not exceed the allowable tension.
- 3-Although the common method of mounting the condenser is the equivalent static method, using dynamic method is recommended as well.

Condenser is usually stabilized enough against the overturning moment due to the large number of underneath supports in the initial design.

5-4-2-4- Heat Exchangers

- 1-The stress and overturning moment caused by the earthquake, which is calculated through Equation (5-1) at a fixed part with the foundation shall not exceed the allowable tension and the resistant overturning moment.
- 2-Vertical heat exchangers must be anchored at the height or to the roof.

3-Parts standing on rail must be provided an appropriate stop in the stand floor so as not to come off from the rail. Resistant forces of the stops shall be greater than the seismic force calculated in article 1.

4-Do the detuning of the natural frequency of heat exchangers with the natural frequency of the supporting structure by a proper type of mounting.

The heat exchangers have a high natural frequency and can be considered a rigid body in the seismic analysis.

As long as the supporting structure is healthy, the heat exchanger is not defected by and does not fail due to the seismic force. Therefore, only the overturning moment and the shearing force of the anchor bolt must be taken into consideration.

The natural frequency of the supporting structure means the natural frequency value in which the building starts to vibrate with other systems and equipment.

5-4-2-5- Main Rotating Machine

1-The stress and overturning moment caused by the earthquake, which is calculated through Equation (5-1) using the weight of these machines, must not exceed the allowable stress and resistant overturning moment at parts fixed to the foundation.

2-Seismic design of the main rotating machine is like that of the boiler rotating machine.

The rotating machine of the steam turbine includes the water pump, the condensate pump, pumps like the seawater pump, fans such as gland steam condenser exhausters, and electric motors for the drive of this equipment.

The natural frequency of the rotating machine is very high from the functional request, and it can be considered a rigid body in the seismic design.

The study of the horizontal force caused by the seismic force and tensile force by the overturning moment for a fixed bolt with the foundation of the equipment should be performed.

5-4-2-6- Crane

1-Crane design method

1-1-The crane should be designed to have enough strength to endure the seismic force and so as not to fall.

1-2-The methods of mounting and analyzing the crane are the static method and the equivalent static method.

2-Seismic load

2-1-Horizontal seismic coefficient

2-2-Equivalent static method

a)Equivalent static method

$$K_{SH} = K_H \cdot \beta'_3 \cdot \beta'_4 \cdot \beta_4 \quad (5-3)$$

β_4 : Acceleration response magnification factor; the value of this factor depends on the height of the structure. It is equal to 1 for the heights lower than or equal to 16m, and equal to $0.0125h + 0.8$ for the heights greater than 16m.

β'_3 : Correction factor of support structure

The correction factor related to the supporting structure, considering the tolerance caused by the diversity of the dynamic features of the supporting structure and crane, is calculated as

follows:

- When the crane is set up on the ground and piers:

$$\beta'_3 = 2.0 \quad (5-4)$$

- When the crane is set up on the structure on the building:

$$\beta'_3 = 1 + (\alpha - 1)h / H \quad (5-5)$$

Where,

H: Height of the crane building (m)

h: Height of the crane installation position (m)

α : The constant determined by H

- In the steel structures:

$$\alpha = 3 \quad (H < 33\text{m}) \quad (5-6)$$

$$\alpha = 100 / H \quad (H \geq 33\text{m}) \quad (5-7)$$

- In reinforced concrete structures (RC) or steel framed reinforced concrete structures (SRC):

$$\alpha = 3 \quad (H < 50\text{m}) \quad (5-8)$$

$$\alpha = 150 / H \quad (H \geq 50\text{m}) \quad (5-9)$$

- Slipping correction factor β'_4 :

The standard value of the slipping correction factor β'_4 is shown in Table (5-2).

Table 5-2: Value of β'_4

| Class | Direction of Load | Constraints | β'_4 |
|-------|---------------------|--|--|
| 1 | Right angel to rail | Case constrained by wheel flange or side thrust roller | 1.0 |
| 2 | Parallel to rail | Case constrained by crane anchor etc. | 1.0 |
| 3 | Parallel to rail | Case without constraints | Total number of wheels / number of breaking wheel, 0.56. 0.1 |

- Seismic coefficient calculated through the equivalent static method or the modified equivalent static method is related to the cases where the crane is restrained to the foundation, ground, etc.
- Where the connection to the ground is only frictional, vibration takes place at the wheel to rail connection, and the seismic coefficient, which is calculated through Equation 5-4 using

the value of β'_4 from Table 5-2, is reduced and transmitted to the foundation or the building.

- In the rail crane, the horizontal direction is restrained to the rail of the base by the flange of the wheel, and is therefore completely restrained at stop.
- When designing the running direction, the most unfavorable conditions either of the stop or working must be taken into consideration.

b) Modified equivalent static method

- The modified horizontal seismic coefficient is calculated through the Equation (5-5) considering the natural period of the crane and ground type.

$$K_{MH} = K_H \cdot \beta'_3 \cdot \beta'_4 \cdot \beta_5 \quad (5-10)$$

K_{MH} : Horizontal seismic coefficient

K_H : Horizontal seismic coefficient at the ground level using Equation 3-1

β'_3 : Correction factor of support structure

β'_4 : Slipping correction factor

β_5 : Acceleration response magnification factor (modified seismic coefficient method)

which is calculated as follows:

-When the crane is fixed on the ground

When the crane is set up directly on the ground, the acceleration response magnification factor $\beta_{5(2.5\%)}$ of damping constant corresponding to 2.5% is first obtained from Figure (5-2) based on the proper period of the crane and the type of the ground; then β_5 is calculated through Equation (5-13) where the correction factor η is multiplied based on the value of the damping constant of the target crane.

$$\beta_5 = \beta_{5(2.5\%)} \times \eta \quad (5-11)$$

Value of η is taken from Table (5-3).



Table 5-3: Value of η

| | | | | | | | | |
|----------------------------|------|------|------|------|-----|------|-----|------|
| Damping constant $h_c(\%)$ | 0.5 | 1 | 1.5 | 2 | 2.5 | 3 | 5 | 10 |
| Correction factor η | 1.43 | 1.24 | 1.15 | 1.06 | 1 | 0.94 | 0.8 | 0.62 |

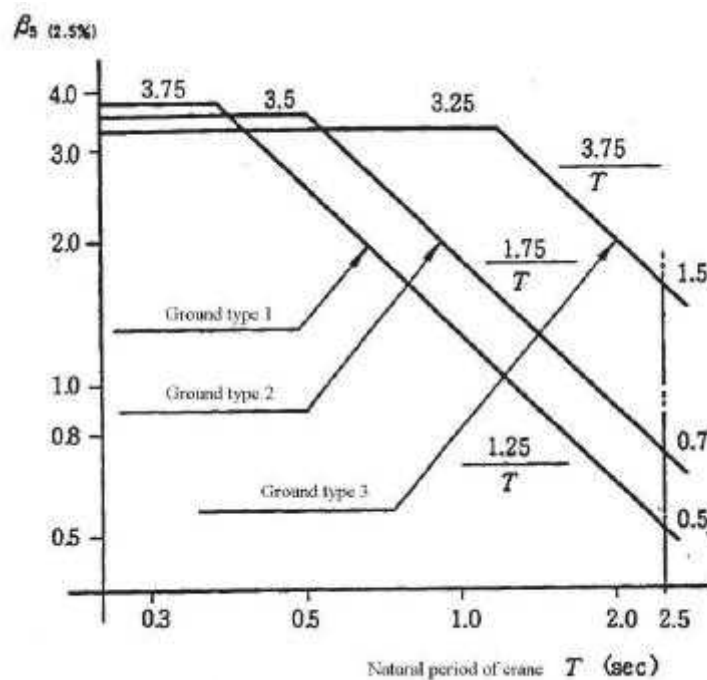
Figure 5-4: Acceleration Response Magnification Factor $\beta_{5(2.5\%)}$

-When the crane is set up on structures like piers or buildings

Acceleration response magnification factor β_5 is calculated through multiplying λ by β_5 .

$$\lambda = 0.7 \times \sqrt{\frac{1 + \gamma}{0.925\gamma + 0.075}} \quad (5-12)$$

γ = weight of the supporting structure / weight of the crane (dead + live)

The λ in this paragraph is calculated through simplifying the response magnification equation through two mass-spring model and considering the rotation (coupling) movement between the crane and the pier or the building.

To make it simple, this factor is calculated only based on crane weight / supporting structure ratio.

Considering the natural period and damping use of dynamic analysis is desirable.

-Calculation of the natural period of the crane

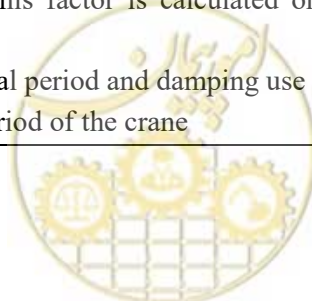

$$T_z = 2\pi \sqrt{\frac{W \cdot \alpha_z}{g}} \quad (5-13)$$

T_z (sec): Natural period in running direction

W : Weight in one side of overhead crane girder, or total weights except leg of bridge crane (t)

g : Gravity acceleration(980cm/sec²)

α_z : Horizontal flexure coefficient of overhead crane running direction girder (cm/tf)

(As shown in Figure (5-3) α_z is the coefficient of movement where the horizontal force $P=1.0$ (tf) is applied)

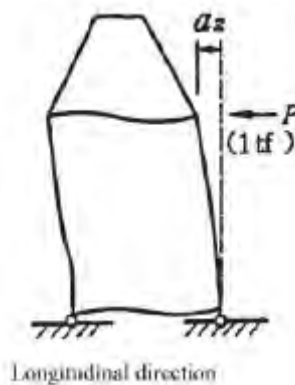

Figure 5-5: Frame Softness

2-2-The side seismic force is calculated through multiplying the crane weight by the horizontal seismic coefficient at the center of gravity.

$$F = K \times W \quad (5-14)$$

W : Weight of the crane

K : Seismic coefficient based on the type of analysis (KSH,KMH)

3-Combination of loads

Static and dynamic gravity loads are combined with the seismic force at the most critical location, quantity, and direction as shown below:

Vertical dynamic load + vertical static load + seismic load

4-Overturning Strength

In order to provide overturning strength, the resistant moment at the point of overturning support must be greater than the overturning moment at the same point.

5-4-3- Allowable Quantities

Allowable stress of the material for turbine and its appurtenance is provided in Chapter-4.

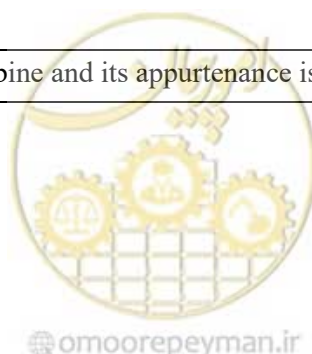

5-4-4- Judgment Criterion

The stress caused by the design seismic force shall not exceed the allowable stress stated in the previous article under any conditions.

5-5-Stack

5-5-1-Procedure

Stacks with the height of 6m or less are designed through equivalent static method; and those with height of more than 6m are designed through dynamic method.

A simplified method of analyzing stacks with height of more than 6m is the moment coefficient, in which the bonding moment and the shearing force are directly applied to the structure as the seismic load.

For stacks that carry excessive load in the upper parts, or their rigidity varies suddenly in the middle parts, the dynamic method shall apply.

For very high stacks, spectra modal analysis and time history analysis shall be used.

5-5-2- Calculations

The seismic force of a standalone stack can be calculated through time history analysis method, or spectra modal analysis method, in addition to the moment coefficient method.

Bonding moment and shearing force caused by the seismic force in the location of the stack are calculated based on the height of the stack as follows:

1-Bonding moment (N.m)

$$M = 0.4 \cdot h \cdot C_{si} \cdot W \quad (5-15)$$

2-Shearing force (N)

$$Q = C_{si} \cdot W \quad (5-16)$$

h: Height from grade of the stack (m)

C_{si}: Vertical stress distribution coefficient

$$C_{si} = K_{SH} \cdot Z \cdot \left(1 - \frac{h_i}{h}\right) \quad (5-17)$$

Z: Regional seismic coefficient

h_i: Height from grade in each part of stack (m)

W: Sum of deal and live loads of the ground part of stack

K_{SH}: Horizontal seismic coefficient

Here, we show the member stress calculation method for the design shearing force and the design bending moment according to the modified moment. Procedure of calculating the member stress is described as follows and illustrated in Figure (5-4)

Member Stress Calculation Method :

1-It is assumed the equivalent load P_i for the horizontal force (top concentrated load and uniform load) aligned as the design shear force Q_i .

2-It is assumed the correction moment ΔM_i for the difference with the design bending Moment M_i and the bending moment m_i by and the equivalent load.



3-The member stress is calculated by the static frame analysis applying the equivalent load P_i and the correction moment ΔM_i .

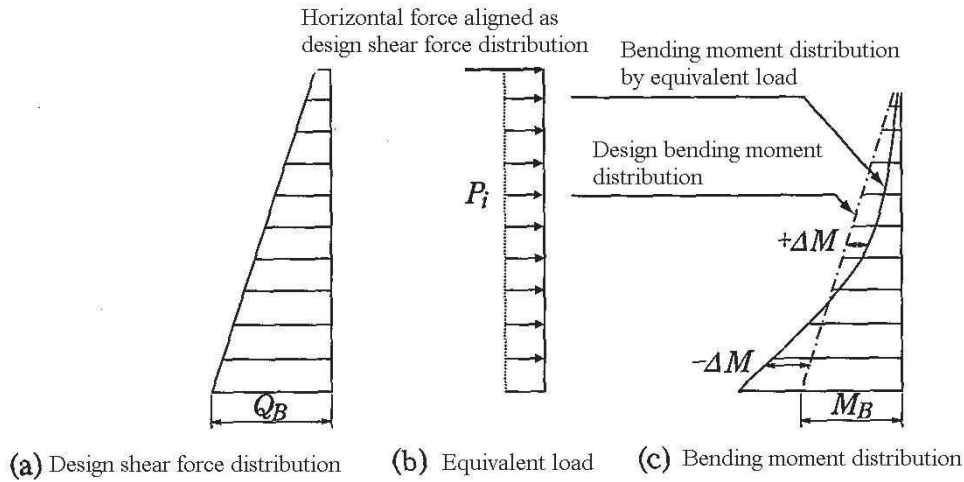

Figure 5-6: Concept of Member Stress Calculation

The modified moment ΔM is calculated through the following equations. The bending moment is considered positive in direction of the equivalent load, and negative in the opposite direction. The concept of the modified moment is illustrated in Figure (5-4).

$$\Delta\alpha_i = \frac{(M_i - m_i) + (M_{i-1} - m_{i-1})}{2} \quad (5-18)$$

$$\left. \begin{aligned} \Delta M_0 &= M_0 - m_0 - \Delta a_0 \\ \Delta M_i &= \Delta a_{i-1} - \Delta a_i \quad (1 \leq i < n) \\ \Delta M_n &= \Delta a_{n-1} \end{aligned} \right\} \quad (5-19)$$

Where,

M_i : Bending moment of stack in height H_i (kNm)

m_i : Bending moment by equivalent load that satisfies design shear force (kNm)

Δa_i : Difference of design bending moment M_i and the bending moment m_i by equivalent load (kNm)

ΔM_i : Correction bending moment (kNm)

H_i : Height of stress calculation from grade(m)



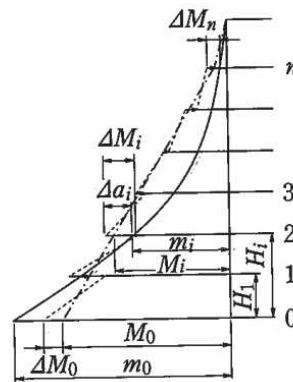

Figure 5-7: Schematic design of the modified bending moment

5-5-3-Allowable Quantities

The quantities of the allowable stress in the stack structure materials depend on the quantities described in part 4-3 of the Steel Materials discussion.

5-5-4- Judgment Criterion

The quantity of stress caused by the seismic forces must not exceed the quantity of allowable stress described in the mentioned articles.

5-6-Cooling Towers

The natural draught type cooling tower should be designed by the paragraph of Stack.

5-7-Control Unit

5-7-1-Procedure

5-7-1-1-Design Method

Controllers and protective devices are generally designed through the equivalent static method or the modified equivalent static method.

Protective devices and controllers of the thermal power plants consist of various switches set up in the site, detector convertor, actuator, cable that connect those device, airpiping etc.

These devices are all of high frequencies and behave rigidly. Therefore, the equivalent static method, or in cases of longer periods, the modified equivalent static method may describe their seismic behavior properly.

5-7-1-2-Design Seismic Force

The seismic force applied to these devices is calculated as follows:

$$F = K_{SH} \times W \quad (5-20)$$

F: Seismic force (N)

W: Weight (N)

KSH: Horizontal seismic coefficient, calculated through Equation (5-23)

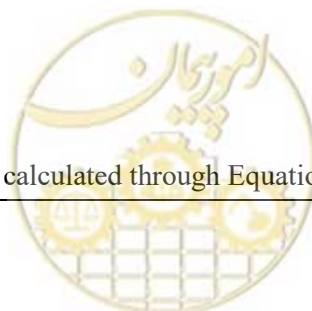

$$K_{SH} = \beta_4 \cdot K_H \quad (5-21)$$

β_4 : Response magnification factor of the device

K_H : Seismic intensity at the ground level in site.

1-Seismic intensity at the ground level is calculated as mounting of the critical channels based on the input acceleration; devise significant factor, zoning, and the magnification factor of the soil.

2-Response magnification factor of the device:

- As response magnification factors of devices are different, it is not possible to attribute a certain value to the various models.
- The manufacturer first conducts the seismic tests on the equipment and then determines the standard seismic strength of the materials.
- For the devices which are hard to test, the response magnification factor of each device is calculated through methods like indirect analysis of seismic strength through the seismic data.
- Response magnification factor of the equipment, according to the seismic design instructions for electrical equipment, is 1.6 for the domestic power supply, and 2.5 for the switchboards.

5-7-1-3-Anchor Bolt Stress Calculation

In controllers and protective devices, the devices are relatively high, compared to the height of the floor, and are likely to overturn in the advent of earthquakes. Therefore, it is necessary to restrain them to the site by adequately strong anchor bolts.

1-Overturning moment of the plate and the load caused by the anchor bolt performance:

The overturning moment is calculated through Equation (5-24).

$$M_t = K_{SH} \times W \times H_O + K_{SV} \times W \times L_1 - W \times L_2 \quad (5-22)$$

M_t : Overturning moment of the plate (N.m)

K_{SH} : Horizontal seismic coefficient, calculated through Equation (5-23)

W : Weight of the plate (N)

H_O : Height of the center of gravity of the plate from the ground level (mm)

K_{SV} : Vertical seismic coefficient ($K_{SV}=K_{SH}/2$)

$L_1 L_2$: Horizontal distance between the center of gravity of the plate and the anchor bolt (mm)



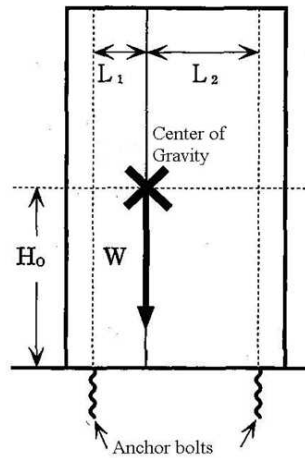

Figure 5-8: Plate Dimensions

In $M_t > 0$ the plate tends to overturn. In this case, Equation (5-22) must apply to the force of anchoring performance on the anchor bolt:

$$T_0 = \frac{M_t}{n \cdot (L_1 + L_2)} \leq T_a \quad (5-24)$$

T_0 : Force of the anchoring performance on a single anchor bolt (N)

n : Number of anchor bolt in one side

T_a : Force caused by anchoring allowable seismic stress on the anchor bolt (N)

2-Anchor bolt strength

The shearing and tensile stresses applied to the anchor bolt during the earthquake is calculated through Equations (5-25) and (5-26).

$$\tau = \frac{K_{SH} \cdot W}{N \cdot A_s} f_s \quad (5-26)$$

$$\sigma = \frac{T_0}{A_s} f_t \quad (5-27)$$

τ : Shearing stress applied to a single anchor bolt during the earthquake (N/mm²)

N : total number of the anchor bolts

A_s : Effective section of the anchor bolt during the earthquake (mm²)

f_s : Allowable stress on the anchor bolt during the earthquake (N/mm²)

f_t : Allowable tensile stress of the anchor bolt during the earthquake (N/mm²)

In $\tau > 44$ N/mm², when the tensile and shearing stresses are applied at the same time, Equation (5-27) shall be true.

$$\sigma \leq f_{ts} = 1.4f_t - 1.6\tau \quad (5-27)$$

f_{ts} : Allowable stress of the earthquake during the earthquake, when the tensile and shearing stresses apply at the same time (N/mm²)

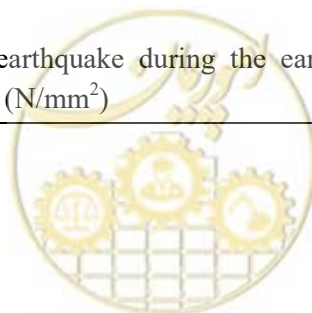

5-7-2-Seismic Intensity of Each Devise

1-Range of controller and protective devices

- a) In high frequency earthquake zones, the design must provide minimum plate intensity ratio.
- b) For earthquake-proof structure, avoid fixing control plate on rubber pads. When being inevitable of using rubber pads for mechanical vibration absorption purposes, measures must be taken to prevent slipping and falling of the plate.
- c) Anchor bolts must be tightened well to the base plate.
- d) When the computers are setup on the floor, it is necessary to prevent the cabinets falling.
- e) Side machines and console table must be fixed.
- f) As the computers consist of systems such as magnetic discs and other accessories, which are not strong enough against the earthquake, choosing proper installation methods is very important, and must be checked separately for seismic strength.

2-Internal switchboard (roofed)

- a) In the site, circuit breaker shall be anchored in the cabin. The circuit breaker design must ensure that it doesn't defect the plate and is not defected due to hitting the plate during the earthquake.
- b) For other issues see article 1.

3-Safety Control System

3-1-Emergency Power Supply System

- a) Since emergency power supply system is a critical system, in order to maintain the safety of the thermal power plant, the design must ensure that the system remains intact during the earthquake and can start to work immediately after the earthquake.
- b) The following issues must be taken into consideration in the seismic design.
 - I. The reservoir must have a proper roof and adequate capacity for supplying the water required by the cooling system.
 - II. For diesel generators with vibration separator support, measures must be taken to prevent the generator slip or fall.
 - III. To prevent splashes of the reservoir during the fluctuations a manhole must be fixed by bolts.
 - IV. Movements caused by the earthquake must be absorbable through bending the pipe.
 - V. For the control panel, switchboard, protective device, start air chest, and facilities like air compressor, fuel reservoir, and daily fuel tank see Chapter 1.

3-2-Storage battery and charger

- a) The following issues must be taken into consideration in seismic design.
 - I. To prevent amplification between natural frequency of the storage battery and the dominant frequency of the region, the design must be conducted for frequencies of 10 Hz and above.
 - II. The structure shall be designed to prevent electrolyte leakage, even if the liquid content fluctuates due to the earthquake.
 - III. Shelf reinforcement and structure design must be conducted without moving or vibrating the storage battery.
 - IV. The layout of batteries must ensure that they are not defected by the seismic force.
 - V. Flexible joints must be used to secure the battery terminal post against the movements of

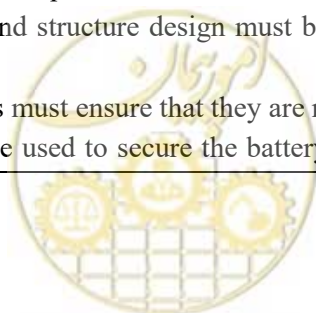

the storage battery and cable vibrations.

For charger see Chapter 1.

3-3-Emergency lighting system

- Flood light must be restrained well to the structure.

4-Paging System

- a) The paging system must limit the level of amplification in the shelves through reducing the height of the center of gravity, or any other methods.
- b) Paging system amplification ratio β_5 is considered 2.5 in the 3rd floor, 1.5 in the second floor, and 1 in the 1st floor.

5-Other issues

5-1-Piping and wiring

- a) Wiring and piping shall be designed flexible enough to endure the massive seismic forces caused by the earthquake.
- b) The following issues must be taken into consideration in seismic design.
 - I. Adequate and reliable flexibility shall be provided at the connections between the devices with various seismic features. Moreover, the flexible joints shall not hit the other sections due to bending, and the isolator shall not fail under any circumstances.
 - II. The following sections must be designed to prevent asymmetric sinking in the basement and the minor sinking shall be endured due to the flexibility.

- Sections crossing the foundation
- Other similar sections

- c) At the routing, consider avoiding the place with danger to which the object falls from the upper part.

5-2-Power generation unit stoppage due to the earthquake

The design must ensure that when the earthquake happens, the power generation unit stops safely.

5-3-Preventing failure of the protective devices.

The protective devices shall be designed to remain intact during the earthquake.

5-7-3- Allowable Quantities

Allowable stress of the structural materials depends on the quantities stated in Chapter 4.

5-7-4- Judgment Criterion

The quantity of stresses caused by the design seismic forces must not exceed the quantity of the allowable stress stated in Chapter 4.



Chapter 6

Seismic Design & Safety Control Petroleum Fuel Reservoirs



6-1-Performance of the Petroleum Fuel Reservoirs

Petroleum fuel reservoirs must be designed to remain intact in level-1 earthquakes and keep operating non-stop.

Under level-2 risk conditions no breakage or deformation resulting in long-term malfunction and no leakage is expected.

6-2-Seismic Design

6-2-1-Procedure

Seismic mounting of the reservoirs, depending on the reservoir capacity is conducted through equivalent static method, modified equivalent static method, or dynamic method.

For design, the allowable stress method is used for level-1, and the formable method is used for the level 2. In the next pages we explain these methods, based on the case, for the power plant petroleum reservoirs, considering their capacity.

6-2-2-Calculation Methods

6-2-2-1-Seismic Coefficient in Static Method

The reservoirs, depending on their capacity are categorized as reservoirs with capacity of more than 1000m³, 500-1000m³, and less than 500m³.

1-Reservoir (1000m³ and above)

The design seismic load is calculated considering the following load combinations:

- Normal operation load + load caused by the earthquake acceleration
- Normal operation load + load caused by the earthquake displacements

1-1-Seismic coefficient related to the earthquake acceleration impacts

Horizontal seismic coefficients K_{MH} and vertical load K_{MV} are calculated in the modified equivalent static method through the following equations:

$$K_{MH} = \beta_5 \cdot K_H \quad (6-1)$$

$$K_{MV} = K_{MH} / 2 \quad (6-2)$$

β_5 : The magnification factor, in which natural period of the reservoir is taken into consideration, and is calculated through Figure 6-1.



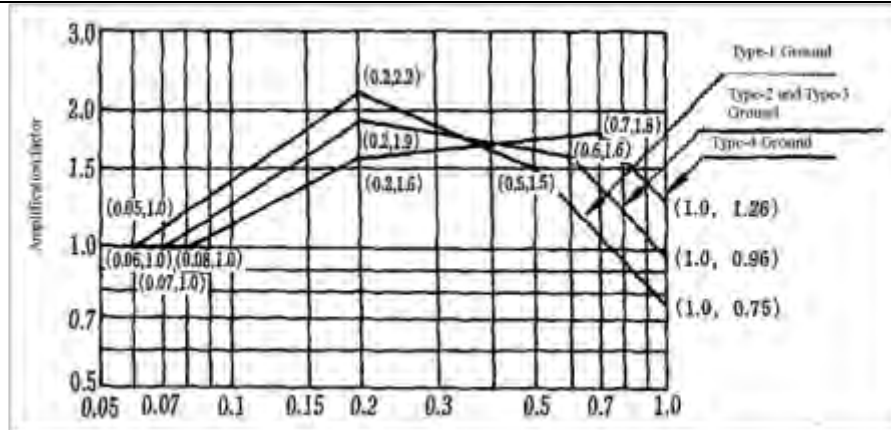

Figure 6-1: Magnification factor of the reservoir based on the natural period

1-2-In this case due to the low acceleration, the effect of the horizontal response is taken into consideration.

$$K_{M2} = 0.15 \cdot \beta_1 \cdot \beta_2 \cdot v_6 \quad (6-3)$$

$$v_6 = \frac{4.5}{T_S} \quad (6-4)$$

K_{M2} : Horizontal seismic coefficient related to the liquid fluctuations.

β_1 : Significance factor (assumed 1)

β_2 : Design input acceleration ratio

v_6 : Magnification factor, in which the natural period of the liquid fluctuation is taken into consideration

T_S : Natural period of the liquid fluctuation (s), which is calculated through Equation 6-9

2-Reservoir (500-1000 m³)

Design seismic load is calculated considering the following load combination.

Normal operation load + load caused by the acceleration

Horizontal seismic coefficient, K_{MH} and vertical load K_{MV} is calculated in the modified static method through Equations (6-1) and (6-2).

3-Reservoir (500 m³ and less)

In this case effects of vertical acceleration and seismic displacements can be disregarded, and the reservoir can be assumed a rigid body and analyzed in equivalent static method, like the main body of the boiler is Chapter 5. Seismic coefficient in this case would be as follows:

$$K_{SH} = K_H \cdot \beta_4 \quad (6-5)$$

$$\beta_4 = \max\{1, 0.0125 \times h + 0.8\} \quad (6-6)$$

h: Height of the reservoir

1-Natural period of the reservoir is calculated through Equation (6-7).

$$T_b = \frac{2J}{\lambda} \cdot \sqrt{\frac{W}{\pi \cdot g \cdot E \cdot t_{(1/3)}}} \quad (6-7)$$

T_b: Natural Period of the reservoir

λ: Quantity calculated through Equation (6-8)

$$\lambda = 0.067 \cdot (H/D_1)^2 - 0.30 \cdot (H/D_1) + 0.46 \quad (6-8)$$

H: The height of the liquid grade (mm)

D_I: Inner diameter of the reservoir located at the site (mm)

W: Weight (N)

g: Gravity acceleration (mm/s²)

E: Elastic module (N/mm²)

T(1/3): Thickness of the side plate at 1/3rd of the height of liquid level from the bottom of the reservoir (except the allowable corrosion) (mm).

J: Modification factor related to the effects of the interaction between foundation, ground, and the main body of the reservoir. It is assumed 1.1 for the external reservoirs with the foundation extended on the ground, and 1 for the other types.

2-Natural period related to the liquid fluctuation is calculated through Equation (6-9).

$$T_s = 2 \cdot \pi \cdot \sqrt{\frac{D_I}{3.68 \cdot g} \cdot \coth\left(\frac{3.68 \cdot H}{D_I}\right)} \quad (6-9)$$

T_s: Natural period of the liquid fluctuation (s)

In reservoirs with capacity of less than 1000m³, due to the small diameter, the height would be bigger than the diameter; therefore the effects of fluctuation are disregarded as the effect of the hydrodynamic pressure caused by the fluctuation is less significant than the effect of the dynamic pressure caused by the gravity.

6-2-2-2-Design Load

After calculating the seismic coefficient in equivalent static method, the design load is designed as follows:

1-Design seismic load

Various loads of the reservoir under normal and earthquake conditions, are considered as follows:

1-1-Normal operation load

- Weight of the reservoir
- Weigh of the liquid
- Live load

1-2-Earthquake load (the vertical load and displacement of the reservoirs smaller than 500 m³ are not considered)

- Hydrodynamic pressure caused by the vertical and horizontal seismic coefficient, due to the earthquake acceleration
- Hydrodynamic pressure caused by the horizontal seismic coefficient, due to the earthquake displacement
- Horizontal force caused by the dead load, due to the horizontal seismic coefficient and the live load
- Vertical load of the reservoir shall be calculated based on the especial weight of the steel.

2-Combination of the design load

Table (6-1) shows the combination of loads and type of the load

| Type of load | | Normal operation | Dynamic effects of earthquake (Vibration) | Static effect of earthquake (geotechnical risks) |
|--|-----------------------|------------------|---|--|
| Dead Load | | ○ | ○ | ○ |
| Liquid Load | | ○ | ○ | ○ |
| Live Load | | ○ | ○ | ○ |
| Hydrodynamic pressure caused by horizontal seismic force | $\geq 1000\text{m}^3$ | × | ○ | ○ |
| | $< 1000\text{m}^3$ | × | ○ ¹ | × |
| Hydrodynamic pressure caused by vertical vibration | $\geq 1000\text{m}^3$ | × | ○ | × |
| | $< 1000\text{m}^3$ | × | ○ ¹ | × |

Note 1: Reservoirs smaller than 500m³, considering the weight of liquid, are assumed rigid bodies.

Note 2: In the above table “○” refers to being considered and “×” refers to not being considered.

6-2-2-3-Examining Allowable Height Related to Liquid Fluctuation

In reservoirs with capacity of 1000m³ and above, the allowable height related to the liquid fluctuation must be less than that of the upper edge of the side plate from the liquid level, which is calculated through Equation (6-10).

$$H_C = 0.45D_I \cdot K_{M2} \quad (\text{mm}) \quad (6-10)$$

HC: Height of the upper edge of the side plate (mm)

6-2-2-4-Examining overturning & slip

It is necessary to examine overturning and slip of the reservoir during the earthquake.

1-Overturning

The overturning moment of the reservoir caused by the vertical factor (rigid displacement of the liquid) and liquid fluctuations, shall not be less than the related resistant moment. MT1 and MT2 are the overturning moments caused by the vertical factor (rigid displacement of the liquid) and liquid fluctuations. The resistant moments related to these two are MRT1 and MRT2, which should:

$$M_{T1} \leq M_{RT1} \quad (6-11)$$

$$M_{T2} \leq M_{RT2} \quad (6-12)$$

2-Slip

The horizontal force in the reservoir, caused by the horizontal factor (rigid displacement of the liquid) and liquid fluctuation shall not exceed the resistant force against the slip

Q_p and Q_{ps} are the horizontal forces of the floor caused by the horizontal factor (rigid

displacement of the liquid) and liquid fluctuations, and the vertical forces of these two are F_1' and F_2' .

$$Q_P \leq F_1' \quad (6-13)$$

$$Q_{PS} \leq F_2' \quad (6-14)$$

1-Overturning

Overturning moments M_{T1} and M_{T2} are caused by the horizontal earthquake and liquid fluctuation. They are calculated through the equations (6-11) and (6-12). The resistant moments M_{RT1} and M_{RT2} are calculated through Equations (6-15) and (6-16)

$$M_{T1} = M_P + M_{PB} \quad (\text{N.mm}) \quad (6-15)$$

$$M_{T2} = M_{PS} + M_{PBS} \quad (\text{N.mm}) \quad (6-16)$$

$$M_{RT1} = (W_T + W_L)(1 - K_{MV}).D/2 + \sigma_a.N_B.A_B.D/4 \quad (\text{N.mm}) \quad (6-17)$$

$$M_{RT2} = (W_T + W_L)D/2 + \sigma_a.N_B.A_B.D/4 \quad (\text{N.mm}) \quad (6-18)$$

M_P & Moment created in the side plate and the floor due to the horizontal factor of the earthquake (N.mm)

M_{PS} & Moment created in the side plate and the floor due to the liquid fluctuations (N.mm)

W_T : Weight of the reservoir excluding the floor plate and the annular plate (N)

W_L : Weight of the reserved liquid (N)

N_B : Number of the anchor bolts

A_B : Area of the anchor bolt section (mm²)

σ_a : Allowable tensile stress of the anchor bolt (N/mm²)

D: Outer diameter of the reservoir

1-1-The moment at the bottom of the side plate caused by the horizontal factor of the earthquake is calculated through Equation (6-19).

$$M'_P = K_{MH} \left(\frac{W_0 H_0 - W_1 H_1}{\beta_5} + W_1 H_1 + W'_S H'_S + W'_r H'_r \right) \quad (6-19)$$

M'_P : Moment at the bottom of the side plate

H'_S : Height of the center of gravity of the side plate from the bottom (mm)

H'_r : Height of the center of gravity of the roof plate from the bottom of the side plate (mm)

W_0 : Weight of the stagnant water (N) (it is calculated using the height of the upper level / diameter of the external reservoir ration, as shown in Figure (6-3))

- W1: Weight of the fluctuating water (N) (calculated as shown in Figure (6-3))
- W_s: Weight of the sider plate and the accessories (N)
- W_r: Weight of the roof and the accessories (N)
- H0: The point where the stagnant water effect applies (mm) (it is calculated using the height of the upper level / diameter of the external reservoir ratio, as shown in Figure (6-2))
- H1: The point where the fluctuating water effects apply (mm)

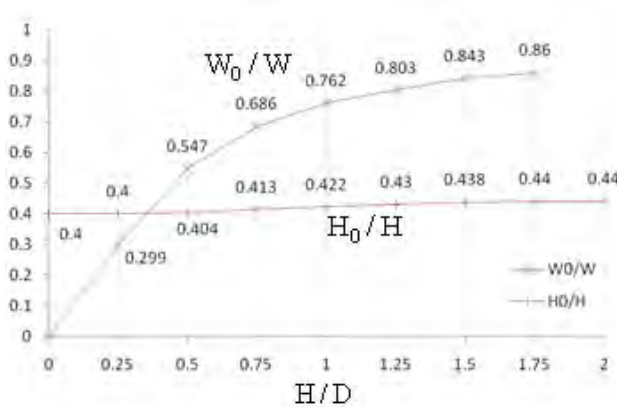

figure 6-2: The relationship between $\frac{H}{D}$ & $\frac{W_0}{W}$ and $\frac{H}{D}$ & $\frac{H_0}{H}$

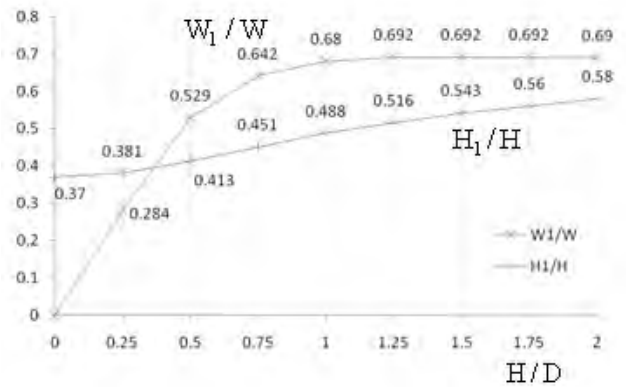

figure 6-3: The relationship between $\frac{H}{D}$ & $\frac{W_1}{W}$ and $\frac{H}{D}$ & $\frac{H_1}{H}$

1-2-The moment created at the bottom due to the earthquake effects is calculated through equation (6-20).

$$M_{PB} = W_0 \cdot H_{0B} \cdot K_{MH} / v_{6..} + W_1 \cdot H_{1B} \left(1 - \frac{1}{\beta_5} \right) K_{MH} \quad (\text{N.mm}) \quad (6-20)$$

- MPB: The moment created at the bottom plate (N.mm)
- H0B& H1B: The converted height (it is calculated using the height of the upper level / diameter of the external reservoir ratio, as shown in Figure (6-4) or (6-5))

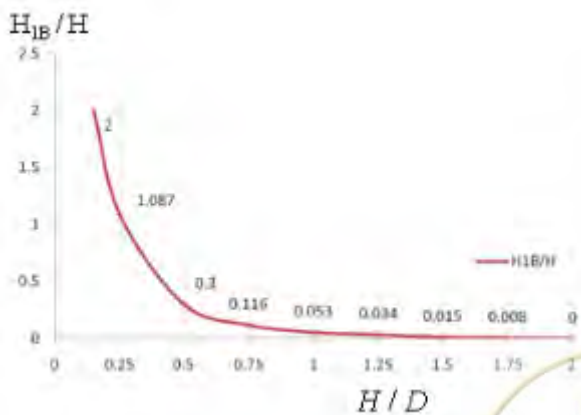

figure 6-4: The relationship between $\frac{H}{D}$ & $\frac{H_{1B}}{H}$

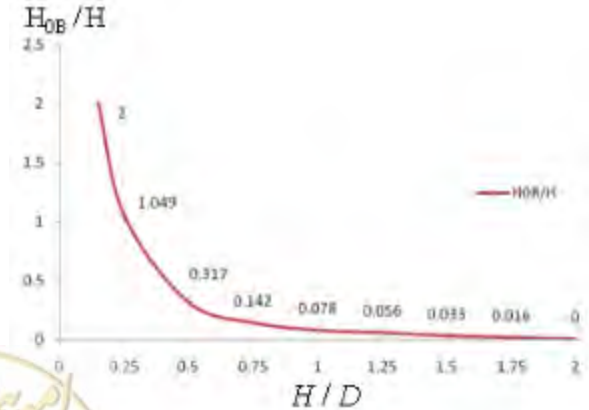
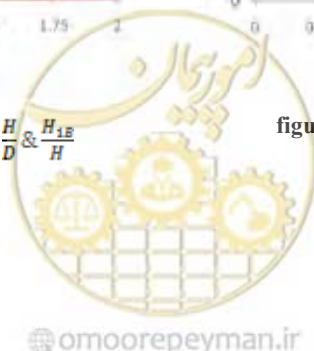

figure 6-5: The relationship between $\frac{H}{D}$ & $\frac{H_{0B}}{H}$



1-3-Moment of the bottom side plate caused by the fluctuation is calculated through Equation (6-21)

$$M'_{PS} = W_0 \cdot \eta_{\max} \frac{\tanh(3.68H/D) - D/3.68H \{1 - \operatorname{sech}(3.68H/D)\}}{1.84} \quad (6-21)$$

M'_{PS} : Moment created in the side plate due to the liquid fluctuation (N.mm)

η_{\max} : Maximum displacement of the liquid level, calculated through Equation (6-22) (mm)

$$\eta_{\max} = 0.42D_I K_{M2} \quad (6-22)$$

1-4-The moment created in the bottom plate due to the liquid fluctuation is calculated through Equation (6-23).

$$M_{PBS} = W_0 \cdot \eta_{\max} \frac{D \cdot 0.148}{H \cosh(3.68H/D)} \quad (6-23)$$

1-5-Moment applied to the side plate

The below equations besides the moments of the bottom side plates can be used for calculating the moments MPS and MP, applied to the side plate.

$$M_P = \left(1 - \frac{Z}{H}\right)^2 \cdot M'_P \quad (6-24)$$

$$M_{PS} = \left(1 - \frac{Z}{H}\right)^{1.3} \cdot M'_{PS} \quad (6-25)$$

Z: height of the bottom of the reservoir

2-Slip

QP and QPS are the horizontal forces caused by the horizontal factor of the earthquake and the liquid fluctuations, which can be calculated through Equations (6-26) and (6-27). The resistant forces against these two are calculated through Equations (6-28) and (6-29).

2-1-The bottom horizontal force Q_P , caused by the vertical factor of the earthquake, is calculated through the equation (6-26).

$$Q_P = K_{MH} \left(\frac{W_0 - W_1}{\beta_5} + W_1 + W'_s + W'_r \right) \quad (6-26)$$

QP: Bottom horizontal force (N)

2-2-Bottom horizontal force Q_{PS} , caused by the fluctuation is calculated through Equation (6-27).

$$Q_{PS} = \frac{\eta_{\max}}{H} \cdot \frac{\tanh(3.68H/D)}{1.84} W_0 \quad (6-27)$$

QPS: Bottom horizontal force caused by the fluctuation (N)

2-3-The resistant force caused by the vertical factor (the rigid displacement of the liquid) and the liquid fluctuations can be calculated through Equations (6-28) and (6-29).

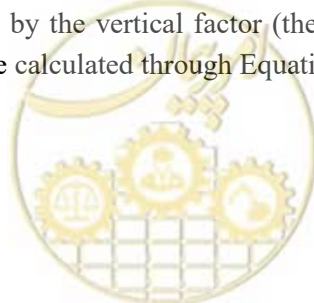

$$F'_2 = (W_T + W_L) \cdot \mu \cdot (1 - K_{MV}) + \frac{1}{2} \cdot \tau_a N_B \cdot A_B \quad (6-28)$$

$$F'_2 = (W_T + W_L) \cdot \mu + \frac{1}{2} \cdot \tau_a N_B \cdot A_B \quad (6-29)$$

W_T , W_L , K_V , N_B , and A_B : As defined earlier

τ_a : Allowable shearing stress of the anchor bolt, which is calculated through Equation (6-30) based on the allowable tensile strength.

$$\tau_a = \sigma_a / \sqrt{3} \quad (\text{N/mm}^2) \quad (6-30)$$

μ : Coefficient of the friction between bottom of the reservoir and the foundation (around 0.4)

6-2-2-5-Examining Stress Created During Earthquake

For the stress created during the earthquake, the following issues must be examined.

1-Circumferential tensile stress of the side plate

Circumferential tensile stress of the side plate, which is calculated through Equation (6-31), must be smaller than the allowable stress.

$$\sigma_c = \frac{P \cdot D}{2t} \quad (6-31)$$

$$P = P_{ST} + \sqrt{P_h^2 + P_v^2} \quad (6-32)$$

σ_c : Circumferential tensile stress

t: Thickness of the plate (mm) excluding the allowable corrosion

PST: Hydrostatic pressure (MPa)

Ph: Hydrodynamic pressure applied to the side plate due to the horizontal factor of the horizontal earthquake (MPa)

PV: Hydrodynamic pressure applied to the side plate due to the vertical factor of the vertical earthquake (MPa)

Equation (6-33) shall be used to work out the hydraulic pressure caused by the liquid fluctuations.

$$P = P_{ST} + P_S \quad (6-33)$$

PST: Hydrostatic pressure (MPa)

PS: Dynamic hydraulic pressure applied to the side plate due to the fluctuation

2-Corner of the side plate and annular plate or bottom plate

The partial stress created at the corners of the side plate, annular plate, or the bottom plate must be smaller than the allowable stress.

This stress is a secondary stress, which can be calculated through Equations (6-34) and (6-35).

2-1-Unrestrained

The bending stress created at the corner of the annular plate due to the earthquake is calculated

through Equation (6-34).

$$\Delta\sigma_B = \frac{12}{t_B^2} \left| M_m \cdot M_o + M_v \cdot V_1 + M_q \frac{P_1}{K_B} D_B \right| \quad (6-34)$$

M_o : Indefinite static moment created at the bottom corner of the plate (N.mm/mm)

V_1 : Vertical force at the bottom end of the plate, caused by the overturning moment of the earthquake (N.mm)

P_1 : Hydrodynamic pressure at the corner (MPa)

K_B : Module of the soil response factor (N/mm³)

D_B : Bending strength of the annular plate, calculated through Equation (6-55) (N.mm)

t_B : Thickness of the annular plate (mm)

M_m, M_v, M_q : Effect coefficient of the parameters $M_o, V_1, \frac{P_1}{K_B} D_B$, which are

calculated through Equations (6-48), (6-49), and (6-50).

The bending stress of the corners of the annular plate during the earthquake is calculated through Equation (6-35).

$$\Delta\sigma_B = 2K\alpha_m P_0 \frac{D}{2 \cdot t_L} \quad (6-35)$$

K : Stress indicator, as shown in Figure (6-6)

t_L : Thickness of the bottom of the side plate (excluding the allowable corrosion) (mm)

t_B : Thickness of the annular plate (mm) (used in Figure (6-6) for calculating K)

α_m : Hydrodynamic pressure distribution influence number

P_0 : Hydrodynamic pressure at the corner (MPa)

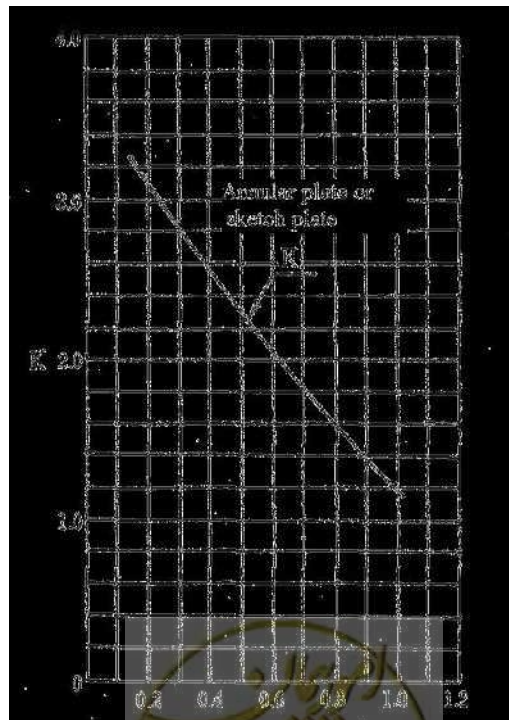

Figure 6-6: Plate thickness ratio (thickness of the side plate / thickness of the annular plate)

3-Buckling stress of the reservoir wall

The buckling stress caused by the horizontal and vertical factors of the earthquake and the liquid fluctuations must not exceed the allowable stress.

Axial compression stress created in the side plate is calculated through Equation (6-36).

$$\sigma_b = \frac{N}{A} + \frac{2M_p}{AD_I} \quad (6-36)$$

σ_b : Axial compression stress (N/mm²)

N: Vertical load considering the vertical seismic coefficient (N)

A: Section area (mm²)

M_p : Moment of the side plate (N.mm)

The moment M_{ps} (N.mm) of the side plate, created by the liquid fluctuation, may be calculated through Equation (6-37), for examining the liquid fluctuation.

$$\sigma_b = \frac{N}{A} + \frac{2M_{ps}}{AD_I} \quad (6-37)$$

1-Method of calculating the hydrodynamic pressure applied to the side panel due to the horizontal earthquake

$$P_h = P_{h0} + P_{h1} \quad (6-38)$$

P_h : Hydrodynamic pressure on the side plate at the height Z from the bottom (MPa)

P_{h0} and P_{h1} : Calculated through Equations (6-39) and (6-40)

$$P_{h0} = \left\{ \sum_{i=0}^5 C_{oi} \left(\frac{Z}{H} \right)^i \right\} \frac{\rho \cdot H \cdot K_{MH}}{\beta_5} \quad (6-39)$$

$$P_{h1} = \left\{ \sum_{i=0}^5 C_{li} \left(\frac{Z}{H} \right)^i \right\} \left(1 - \frac{1}{\beta_5} \right) \frac{\rho \cdot H \cdot K_{MH}}{\beta_5} \quad (6-40)$$

ρ : Especial weight of the reserved fluid (N.mm³)

C_{oi} , C_{li} : Valued acquired from Tables (6-2) and (6-3) based on the upper level height / external reservoir diameter ratio

Table 6-2: Coefficients C_0

| H/D | C_{00} | C_{01} | C_{02} | C_{03} | C_{04} | C_{05} |
|-------|----------|----------|----------|----------|----------|----------|
| 0.15 | 0.811 | -0.130 | 0.688 | -4.21 | 5.7 | -2.85 |
| 0.20 | 0.824 | -0.132 | 0.688 | -4.24 | 5.71 | -2.85 |
| 0.30 | 0.826 | -0.133 | 0.703 | -4.26 | 5.74 | -2.87 |
| 0.40 | 0.794 | -0.129 | 0.706 | -4.11 | 5.54 | -2.79 |
| 0.50 | 0.742 | -0.132 | 0.811 | -4.22 | 5.65 | -2.85 |
| 0.60 | 0.684 | -0.133 | 0.892 | -4.23 | 5.65 | -2.86 |
| 0.70 | 0.626 | -0.131 | 0.952 | -4.21 | 5.62 | -2.86 |

| | | | | | | |
|------|-------|--------|------|-------|------|-------|
| 0.80 | 0.572 | -0.132 | 1.03 | -4.24 | 5.66 | -2.88 |
| 1.00 | 0.481 | -0.133 | 1.13 | -4.26 | 5.73 | -2.94 |
| 1.20 | 0.410 | -0.134 | 1.20 | -4.33 | 5.87 | -3.02 |
| 1.40 | 0.356 | -0.136 | 1.26 | -4.42 | 6.06 | -3.12 |
| 1.60 | 0.313 | -0.140 | 1.32 | -4.56 | 6.30 | -3.23 |
| 1.80 | 0.279 | -0.144 | 1.37 | -4.71 | 6.54 | -3.34 |
| 2.00 | 0.252 | -0.148 | 1.43 | -4.87 | 6.79 | -3.45 |



Table 6-3: Coefficients C_{li}

| H/D \ C_{li} | C_{10} | C_{11} | C_{12} | C_{13} | C_{14} | C_{15} |
|------------------|----------|----------|----------|----------|----------|----------|
| 0.15 | 0.807 | 0.234 | -1.45 | 0,547 | -0.197 | 0.0626 |
| 0.20 | 0.813 | 0.267 | -1.48 | 0,588 | -0.217 | 0.0287 |
| 0.30 | 0.792 | 0.277 | -1.15 | -0.0335 | 0.418 | -0.305 |
| 0.40 | 0.731 | 0.241 | -0.472 | -1.30 | 1.70 | -0.900 |
| 0.50 | 0.644 | 0.193 | 0.265 | -2.62 | 3.05 | -1.52 |
| 0.60 | 0,551 | 0.133 | 1.01 | -3.98 | 4.47 | -2.17 |
| 0.70 | 0.462 | 0.0810 | 1.61 | -5.06 | 5.63 | -2.72 |
| 0.80 | 0.385 | 0.0377 | 2.08 | -5.92 | 6.62 | -3.19 |
| 1.00 | 0.267 | -0.0301 | 2.67 | -7.05 | 8.05 | -3.90 |
| 1.20 | 0.188 | -0.0772 | 2.97 | -7.72 | 9.09 | -4.44 |
| 1.40 | 0.136 | -0.112 | 3.12 | -8.18 | 9.92 | -4.88 |
| 1.60 | 0.100 | -0.139 | 3.19 | -8.50 | 10.6 | -5.24 |
| 1.80 | 0.0753 | -0.162 | 3.23 | -8.79 | 11.2 | -5.55 |
| 2.00 | 0.0580 | -0.184 | 3.27 | -9.09 | 11.8 | -5.83 |

2- Method of calculating hydrodynamic pressure on the side plate due to the vertical factor of the earthquake.

$$P_V = \rho H \left\{ \left(1 - \frac{Z}{H} \right) \frac{K_{MV}}{\beta_5} + 0.811 \cos \left(\frac{\pi Z}{2H} \right) \left(1 - \frac{1}{\beta_5} \right) K_{MV} \right\} \quad (6-41)$$

P_V : Hydrodynamic pressure of the side plate at the height of Z from the bottom

Z : Height from the bottom

3- Method of calculating hydrodynamic pressure on the side plate due to the liquid fluctuation.

$$P_S = \rho \eta_{\max} \frac{\cos h(3.68Z/D)}{\cos h(3.68H/D)} \quad (6-42)$$

P_S : Hydrodynamic pressure on the side plate at the height of Z from the bottom due to the liquid fluctuation (MPa)

η_{\max} : Maximum displacement of the liquid surface, which is calculated through Equation (6-22) (mm)

4- Range of the bending stress on the corner of the annular plate during the earthquake

$$\Delta \sigma_B = \frac{12}{t_B^2} \left| M_m \cdot M_o + M_V \cdot V_1 + M_q \frac{P_I}{K_B} D_B \right| \quad (6-43)$$

In the above paragraph, the indefinite static moment created at the bottom corner of the side plate is calculated through the following equations.

V_1 : Vertical force at the bottom end, caused by the overturning moment of the earthquake (N/mm).

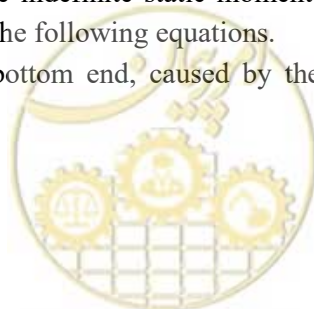

$$M_0 = \frac{1}{\left(\frac{\theta_n}{D_B} + \frac{1}{2K_s D'_s}\right)} \left\{ \frac{P_1 R^2 K_s}{E \cdot t} - \theta_v \frac{V_1}{D_B} - \theta_q \frac{P_1}{K_s} \right\} \quad (6-44)$$

$$\theta_m = \frac{1}{2f^2} (2c^2 + f^2 + 1 + 2cs) \frac{1}{2\beta} \quad (6-45)$$

$$\theta_v = \frac{c^2}{f^2} \frac{1}{2\beta^2} \quad (6-46)$$

$$\theta_q = - \left\{ \frac{1}{2f} \left(f - \frac{1}{f} \right) + \frac{sc}{f^2} + \frac{s^2}{f^2} \right\} \beta \quad (6-47)$$

$$M_m = - \frac{1}{2f^2} (f^2 + 1 + 2cs) \quad (6-48)$$

$$M_v = - \frac{1}{4f^2} (c^2 - s^2 + 2cs - f^2) \frac{1}{\beta} \quad (6-49)$$

$$M_q = \frac{2s^2}{f^2} \beta^2 \quad (6-50)$$

$$f = e^{\beta \cdot l} \quad (6-51)$$

$$c = \cos \beta \cdot l \quad (6-52)$$

$$s = \sin \beta \cdot l \quad (6-53)$$

$$\beta = \sqrt[4]{\frac{K_B}{4D_B}} \quad (6-54)$$

$$D_B = \frac{E \cdot t_B^3}{12(1 - \nu^2)} \quad (6-55)$$

$$K_s = \sqrt[4]{\frac{3(1 - \nu^2)}{R^2 t_L^2}} \quad (6-56)$$

$$D'_s = \frac{E \cdot t_L^3}{12(1 - \nu^2)} \quad (6-57)$$

KB: Module of the soil response (N/mm³)

tB: Thickness of the annular plate (mm)

l: Excessive length of the annular plate at the bottom from the outer edge of the side plate, as shown in Figure 6-7

tL: Thickness of the side plate at the lowest part (excluding the allowable corrosion) (mm)

R: Average radius of the reservoir (mm)

P1: Hydrodynamic pressure at the corner (Mpa)

ν : Poisson's ratio



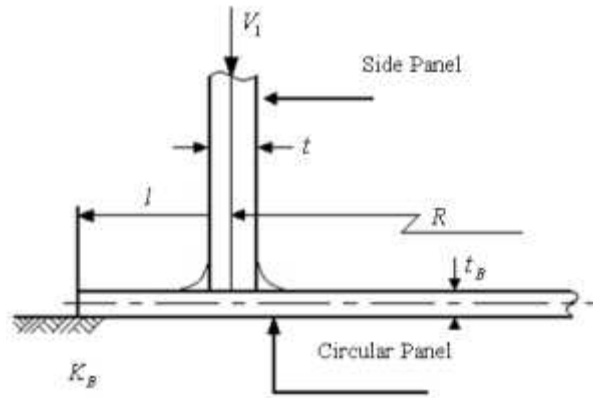

Figure 6-7: Parameters of dimension for fuel reservoir

The hydrodynamic pressure on the corner P_1 and the vertical force V_1 applied to the lower end of the side plate due to the overturning moment of the earthquake can be calculated as follows.

4-1-For the range of the bending stress on the annular plate due to the rigid displacements of the liquid under the effect of the horizontal factor of the earthquake we would have:

$$P_1 = \sqrt{3}K_{MH}\rho_1H \left\{ 1 - \frac{1}{2} \tanh\left(\frac{\sqrt{3}R}{H}\right) \right\} \quad (6-58)$$

$$V_1 = \frac{M_{T1}}{\pi R^2} \quad (6-59)$$

ρ_1 : Density of the liquid content

M_{T1} : Overturning moment caused by the horizontal earthquake (N.mm)

4-2-For the range of the bending stress on the annular plate caused by the rigid displacement of the liquid under the effect of the vertical factor of the earthquake, we would have:

$$P_1 = K_{MV}\rho H \quad (6-60)$$

$$V_1 = K_{MV} \cdot \frac{W'_S + W'_R}{\pi D} \quad (6-61)$$

W'_S : Total weight of the side plate (N)

W'_R : Total weight of the part of the roof which supports the side plate (N)

The range of the tensile stress created in the annular plate, when horizontal and vertical factors are considered at the same time, is equal to the square root of the sum of the squares of the bending stress range of each earthquake.

$$\Delta\sigma_B = \sqrt{(\Delta\sigma_{BH})^2 + (\Delta\sigma_{BV})^2} \quad (6-62)$$

$\Delta\sigma_{BH}$: Bending stress range of the horizontal factor

$\Delta\sigma_{BV}$: Bending stress range of the vertical factor

4-3-For the bending stress range of the annular plate caused by the displacement factor of the earthquake, we would have:



$$P_1 = \frac{\rho \eta_{\max}}{\cos h\left(3.682 \frac{H}{D}\right)} \quad (6-63)$$

$$V_1 = \frac{4M_{T2}}{\pi D^2 t} \times t = \frac{4M_{T2}}{\pi D^2} \quad (6-64)$$

η_{\max} : Maximum height of responsive fluctuations (mm)

M_{T2} : Overturning moment of the liquid fluctuation (N.mm)

Maximum height of the responsive fluctuations η is calculated through Equation (6-65)

$$\eta = 0.418D\psi \quad (6-65)$$

$$\psi = \frac{0.00641}{T_s} S_{V0} \beta_2 \quad (6-66)$$

S_{V0} : Velocity spectrum value

β_2 : Seismic zone factor

T_s : Natural period of the liquid fluctuation

4-4-Range of the bending stress caused by the earthquake at annular plate to side plate joint

Hydrodynamic pressure P_0 (MPa) on the side plate and Dynamic hydraulic pressure distribution influence number α_m required for calculating the range of the bending stress of the annular plate in the side plate and side plate joint during the earthquake is calculated through the following equation. Corner stress / apparent stress ratio K (stress index) of the vertical direction of the side plate is calculated using annular plate thickness / side plate thickness ratio (t_B/t_L) through Equation (6-67).

$$K = 3.7013 - 3.0459 \left(\frac{t_B}{t_L} \right) + 0.47294 \left(\frac{t_B}{t_L} \right)^2 \quad (6-67)$$

- a) Range of the bending stress of annular plate caused by horizontal acceleration of the earthquake

$$\alpha_m = 1 + 0.114 \left(\frac{H}{D} \right) + 0.6 \left(\frac{H}{D} \right)^2 \quad (6-68)$$

$$P_o = \frac{\sqrt{3}}{2} K_{MH} \rho H \tanh \left(\frac{\sqrt{3}D}{2H} \right) \Big|_{z=0} \quad (6-69)$$

- b) Range of the bending stress of the annular plate caused by vertical acceleration of the earthquake

$$\alpha_m = 0.1 \quad (6-70)$$

$$P_o = K_{MV} \rho H \Big|_{z=0} \quad (6-71)$$

- c) Range of the bending stress of the annular plate caused by the displacements of the earthquake

$$\alpha_m = 1 + 0.114 \left(\frac{H}{D} \right) + 0.6 \left(\frac{H}{D} \right)^2 + \beta \left\{ 0.025 + 0.112 \left(\frac{H}{D} \right)^2 + 0.8 \left(\frac{H}{D} \right)^3 \right\} \quad (6-72)$$

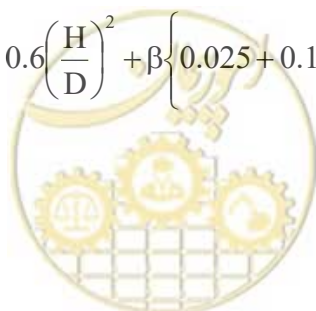

$$P_0 = \rho \eta \frac{\cos h\left(3.682 \frac{Z}{D}\right)}{\cos h\left(3.682 \frac{H}{D}\right)} \Big|_{z=0} \quad (6-73)$$

$$\beta = \frac{P_1 - P_0}{P_0} \quad (6-74)$$

β : Pressure gradient

P_1 : Hydrodynamic pressure on the side plate, equal to the value of Equation (6-73), when $Z=H$

6-2-2-6-Calculating the Ultimate Lateral Strength

Ultimate lateral strength of the reservoir Q_y shall be bigger than required horizontal load-carrying capacity Q_{dw} , caused by the seismic effects, which is calculated through Equation (6-75)

$$Q_y = \frac{2\pi R^2 q_y}{0.44H} \quad (6-75)$$

Q_y : Ultimate lateral strength (N)

q_y : Uplift resistance per unit plate width of the tank bottom, calculated through Equation (6-76)

$$q_y = \frac{2t_b \sqrt{1.5P_{ST}\sigma_{yr}}}{3} \quad (6-76)$$

t_b : Real annular plate thickness

P_{ST} : Static hydraulic pressure

σ_{yr} : Annular plate real yield strength

Moreover, the required horizontal load-carrying capacity caused by the seismic effects is calculated through the following Equation.

$$Q_{dw} = K_{SH} \cdot \beta_3 \cdot v_p \cdot D_S \cdot W_0 \quad (6-77)$$

Q_{dw} : Required horizontal load-carrying capacity (N)

β_3 : Site amplification factor, considering the natural period of external reservoir

v_p : Plastic design coefficient (1.5)

D_S : Structural characteristics factor

W_0 : Weight of effective liquid(N)

Method of calculating structural characteristic factor (D_S) in calculation of the required horizontal load-carrying capacity is as follows.

1-When the yield point ration (yield point / tensile strength of the annular plate) is less than 80%

$$D_S = \frac{1}{\sqrt{1+84(T_1/T_e)^2}} \quad (6-78)$$

2-When the yield point ratio is 80% or more

$$D_S = \frac{1}{\sqrt{1+24(T_1/T_e)^2}} \quad (6-79)$$



T_1 : Period of the reservoir main body, which is calculated considering only the uplift of the bottom plate.

$$T_1 = 2\pi\sqrt{W_0 / gK_1} \quad (6-80)$$

T_e : Period of the reservoir main body, which is calculated considering uplift of the bottom plate and deformation of the side plate.

$$T_e = \sqrt{T_b^2 + T_1^2} \quad (6-81)$$

K_1 : Spring constant of the entire tank at uplift

$$K_1 = 48.7R^3 \kappa_1 / H^2 \quad (6-82)$$

k_l : Spring constant concerning uplift per unit width

$$\kappa_1 = q_y / \delta_y \quad (6-83)$$

δ_y : Uplift displacement at yield strength

$$\delta_y = 3t_b \sigma_y^2 / 8PE \quad (6-84)$$

T_b : Natural period of tank by bulging vibration of side plate

6-3-Seismic Design of Fuel Reserve Equipment

The following issues must be taken into consideration in seismic design of the fuel reserve equipment including loading arms, pumps, and heat generator system.

- 1-Seismic design of the equipment must follow the static method.
- 2-Vertical seismic coefficient is equal to $\frac{1}{2}$ of the horizontal seismic coefficient and the two must be applied at the same time.
- 3-Horizontal seismic coefficient is calculated using significance coefficient of 1.
- 4-Seismic design of the fuel reserving equipment is limited to the anchor bolt and the main body foundation.
- 5-When assessing the overturning moment and vibration of the equipment, increase or decrease of the weight caused by the vertical factor effect on the overturning moment and fraction force caused by the horizontal seismic force.

6-4-Allowable Quantities

1-Allowable stress

- Allowable tensile stress (S) is equal to 60% of the minimum yield point or 60% of the 0.2% yield strength.
- Allowable stress for studying the compression stress buckling is assumed to be the minimum quantity between S and S'. S' is calculated through Equation (6-85)

$$S' = \frac{0.4 \cdot E \cdot t_{sb}}{\gamma \cdot D} \quad (6-85)$$

S and S': Allowable stress (N/mm²)

t_{sb} : Thickness of side plate in steps where buckling occur (mm)

γ : 2.25

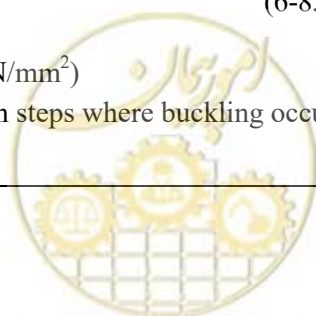

2-Allowable stress during the earthquake

- Allowable stress during the earthquake is 1.5 S
- Allowable tensile stress of the bolt during the earthquake is 1.5 times of the normal conditions.
- Allowable buckling stress during the earthquake is the minimum value of S and S'.

When the capacity of the reservoir is 500 – 1000 m³, the allowable stress S'' would be as follows. For reservoirs bigger than 1000 m³, when the exact value of S'' is not mentioned in the test results or valid codes, it can be calculated through Equation (6-86)

$$S'' = \frac{0.4 \cdot E \cdot t}{\gamma \cdot D} \quad (6-86)$$

S'' : Allowable compression stress during the earthquake (N/mm²)

t: Thickness of the side plate where the buckling occurs (mm)

γ : 1.1

Allowable bending stress

The allowable range of bending stress created in the annular plate is assumed $2\sigma_y$.

$$\Delta\sigma_B' \leq 2 \cdot \sigma_y \quad (6-87)$$

$\Delta\sigma_B'$: Range of the bending stress in the annular plate caused by the earthquake (N/mm²)

σ_y : Minimum yield point or 0.2% strength of annular plate (N/mm²)

Domain of the stress caused by the continuous load for the bending stress is estimated considering the seismic load occurring at the corner and can be assessed as the secondary stress.

6-5-Judgment Criterion

Stress must be calculated using the excessive load created under the most unfavorable conditions in direction of the seismic load.

The calculated stress must not be bigger than the allowable stress.



Chapter 7

Seismic Design & Safety Control Gas Fuel Tanks



7-1- Performance of Gas Fuel Tanks

The gas fuel tanks are expected to operate non-stop under level-1 risk conditions.

Under level-2 conditions the tanks may be partially defected, but shall start to work shortly after a quick repair.

Liquefied gas equipment must be classified into importance categorized based on the flammability and hazardous gas content; and the seismic design of the equipment shall be based on this categorization.

In terms of significance, the aboveground tanks are categorized as “important” and “very important”.

7-2-Seismic Design

7-2-1- Design Stages

The equipment that require seismic design includes:

- Aboveground tank
- Firefighting installations
- Safety equipment

1-Seismic design of the tank

The liquefied natural gas tank, considering the below issues, are designed to endure the liquid acceleration and sloshing. The potential defects are:

- Defects occurring in various parts due to the stress caused by the seismic force and hydraulic pressure changes caused by the liquid sloshing
- Defect occurring in the upper sections of the tanks due to the sloshing impacts
- Uplift, overturning, buckling, distortion, and slip of the tank due to the hydraulic pressure caused by the liquid sloshing
- Sink, deformation, and defect of the foundation due to the seismic force

1-1-The seismic load of the facilities with medium or low importance, and with diameter and height of less than 10m is calculated through the equivalent static method; that of the other facilities is calculated through the modified equivalent static method.

1-2-Range of displacement in analysis of the liquid sloshing is determined considering the long period vibrations caused by the earthquake, importance category, and design acceleration ratio.

1-3-Responses to the impacts caused by the earthquake acceleration and the liquid sloshing are calculated separately and considering the following issues:

- a) The damping factor is determined based on the characteristics of the structure and physical properties of the liquid.
- b) Acceleration response (level-1 risk) of the natural period used in the structure analysis under level-1 risk conditions is determined considering the rigidity of the liquid and the tank.
- c) Tank response analysis is performed considering the liquid sloshing under level-2 risk conditions through the following methods:
 - Triple amplifying waves method
 - Time history method

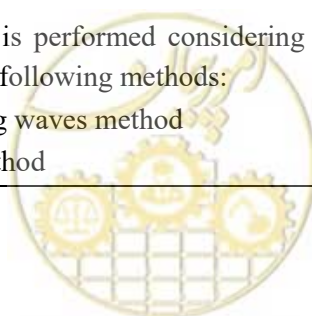

– Spectra method

2-Seismic design of the equipment

The equipment usually includes steam generators, heater, pump, and compressor. Seismic loading of this equipment is performed through the equivalent static method. For level-1 risk conditions, the design is performed through allowable stress method. For level-2 risk conditions, the design is performed through the formable design method.

3-Seismic design of the safety equipment

In natural gas facilities the concerned equipment includes:

- Flare stack and vent stack
- Containers like dust separator, seals, and drums
- Oil transfer pump
- Safety control facility

4-The following concerns shall be taken into consideration in the seismic design:

- 4-1-For the level-2 risk conditions, the importance category of each facility shall be decided through judging substitution of the equipment.
- 4-2-Seismic design of the safety equipment related to the “important” and “very important” facilities is performed through the equivalent static method; yet, when necessary the mode analysis or the time history response analysis method are accepted, considering the shape and vibration characteristics.
- 4-3-It is better to perform the seismic design of the safety equipment related to the second and third importance category through equivalent static method; when necessary, the modified equivalent static method may apply.

7-2-2- Tank Design Methods

7-2-2-1- Allowable Stress Method

In this method, the seismic force stress must not exceed the allowable stress in the following elements:

- 1-Side and bottom plates
- 2-The axial compression stress of the side plate must be less than the allowable stress.
- 3-Anchor bolt or anchor strap
- 4-Roof plate, roof bone, and side of the tank
- 5-In the external tanks: side plates, roof sheeting, roof bone, and the generated moment
- 5-Pump barrel frame
- 6-Cold insulation

In addition to the above mentioned elements, the overturning moment caused by the sloshing and acceleration must not exceed the resistant moment against overturning. Also, the horizontal force caused by two – short period and long period – earthquakes shall not exceed the slip strength.

1-Side and bottom plate strength

1-1-The distribution of the hydrodynamic pressure on the side and bottom plates can be calculated using velocity potential theory.

The method of calculating hydrodynamic and liquid sloshing pressure is as follows:

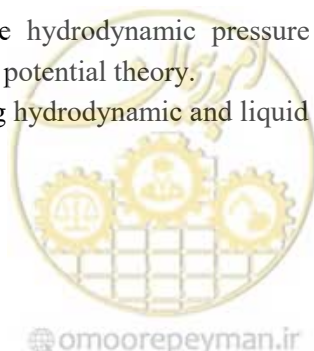

a) Short period earthquake

I- Distribution of pressure (P_{HW}) caused by the horizontal acceleration of the earthquake on the side plate is calculated through Equation (7-1).

$$P_{HW} = \gamma \cdot k_{MH} \cdot H \sqrt{3} \left\{ \left(\frac{y}{H} \right) - \frac{1}{2} \left(\frac{y}{H} \right)^2 \right\} \cdot \tanh \left(\sqrt{3} \cdot \frac{R}{H} \right) \cdot \cos \phi \quad (H > 1.5R)$$

$$P_{HW} = \gamma \cdot K_{MH} \cdot R \cos \phi \quad (H \leq 1.5R) \text{ (MPa)}$$
(7-1)

Pressure on the bottom plate:

$$P_b = \gamma \cdot K_{MH} \cdot \frac{H \sqrt{3}}{2} \frac{\sinh \left(\sqrt{3} \frac{x}{H} \right)}{\cosh \left(\sqrt{3} \frac{\ell}{H} \right)} \text{ (MPa)} \quad (H > 1.5R) \text{ (MPa)} \quad (H \leq 1.5R)$$
(7-2)

$$P_b = \gamma \cdot K_{MH} \cdot R$$

- γ : Weight per unit volume of content fluid
- y : Preferable depth
- x : Preferable length on the bottom plate
- K_{MH} : Modified coefficient of the horizontal earthquake, calculated through Equation (3-3)
- x : Preferable depth (cm)
- H : Maximum height of the liquid level in the reservoir (mm)
- R : Average radius of the reservoir (mm)
- ϕ : Angle of circumference

See the coordinates shown in Fig (7-1) a & b.

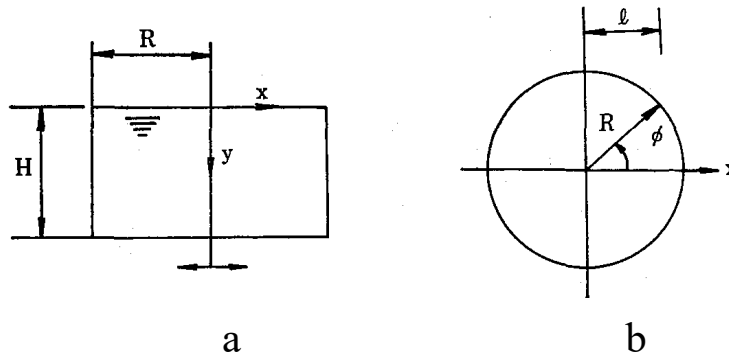

Parameters engaged in Equations (7-1) and (7-2)

II-Distribution of the pressure (P_{VW}) on the side plate and the bottom plate due to the vertical acceleration of the earthquake is calculated through Equation (7-3):

$$P_{VW} = \gamma \cdot K_{MV} \cdot (y) \text{ (MPa)}$$
(7-3)

K_{MV} : Vertical seismic intensity related to the earthquake acceleration

b) Long period earthquake

The hydrodynamic pressure generated in the first uplift of the liquid sloshing is calculated through the following methods:

I-Hydrodynamic pressure on the side plate (P_W)

$$P_w = \gamma \eta_{\max} \frac{\cosh\left(1.841 \frac{y}{R}\right)}{\cosh\left(1.841 \frac{H}{R}\right)} \cos \theta \quad (\text{MPa}) \quad (7-4)$$

η_{\max} : Maximum displacement of liquid level (mm), calculated through Equation (6-22).

Hydrodynamic pressure on the bottom plate (P_{bs})

$$P_{bs} = \gamma \eta_{\max} \frac{J_1(1.841r/R)}{J_1(1.841) \cosh(1.841H/R)} \cos \theta \quad (\text{MPa}) \quad (7-5)$$

r : Dimensions shown in Fig. (7-3) (mm)

$J_1(x)$: The first kind the first order Bessel function

$\gamma, \eta, H, R, \theta$: Similar to i

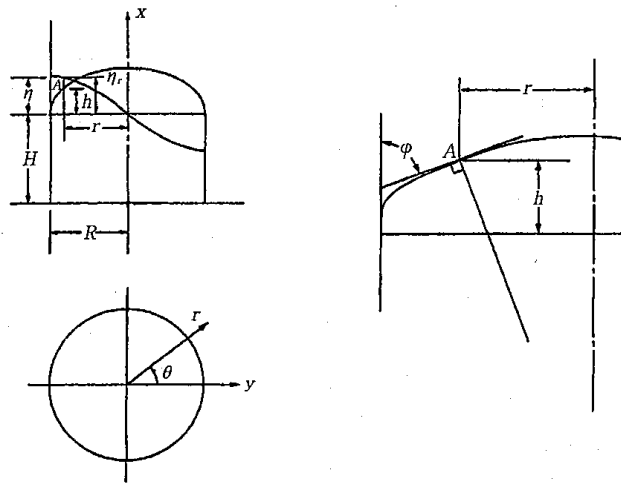

Figure (7-3): Coordinates and height of the wave in sloshing analysis

1-2-The bottom plate (annular plate) connected to the lowest side plate

a) Effective weight and height of the liquid center of gravity

Effective weight and height of the liquid center of gravity are calculated through Figures (7-4), (7-5), (7-6).



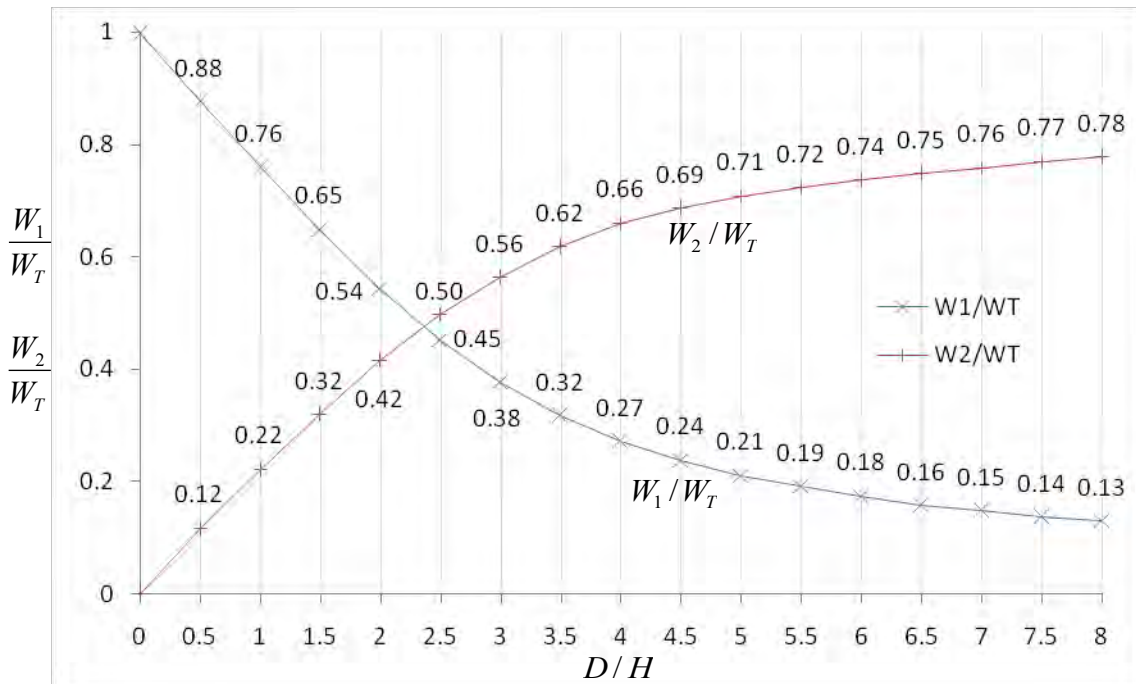

Figure (7-4): Effective weight ratio

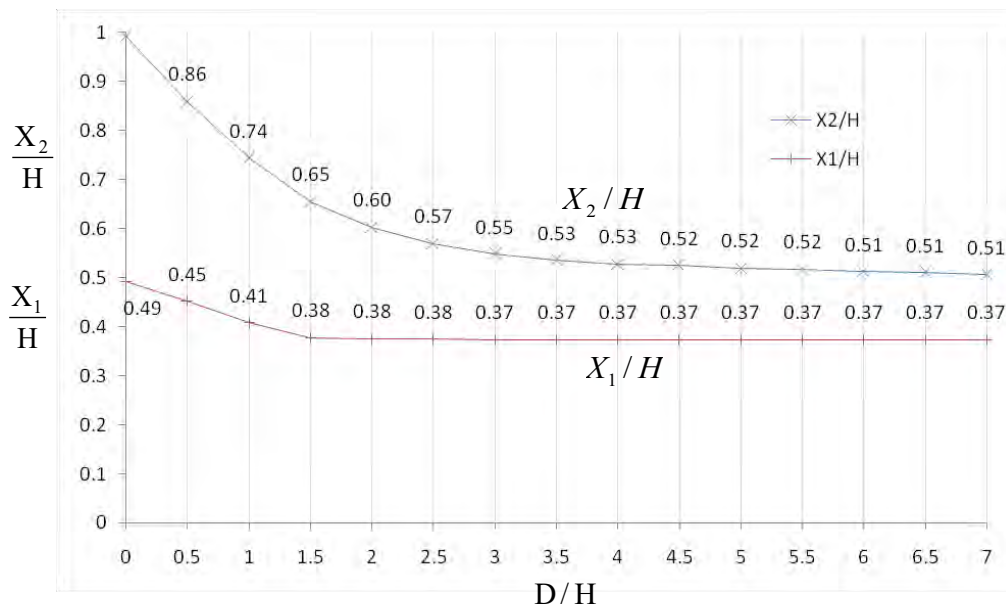

Figure (7-5): Effective weight / height of center of gravity ratio

(Excluding bottom plate)



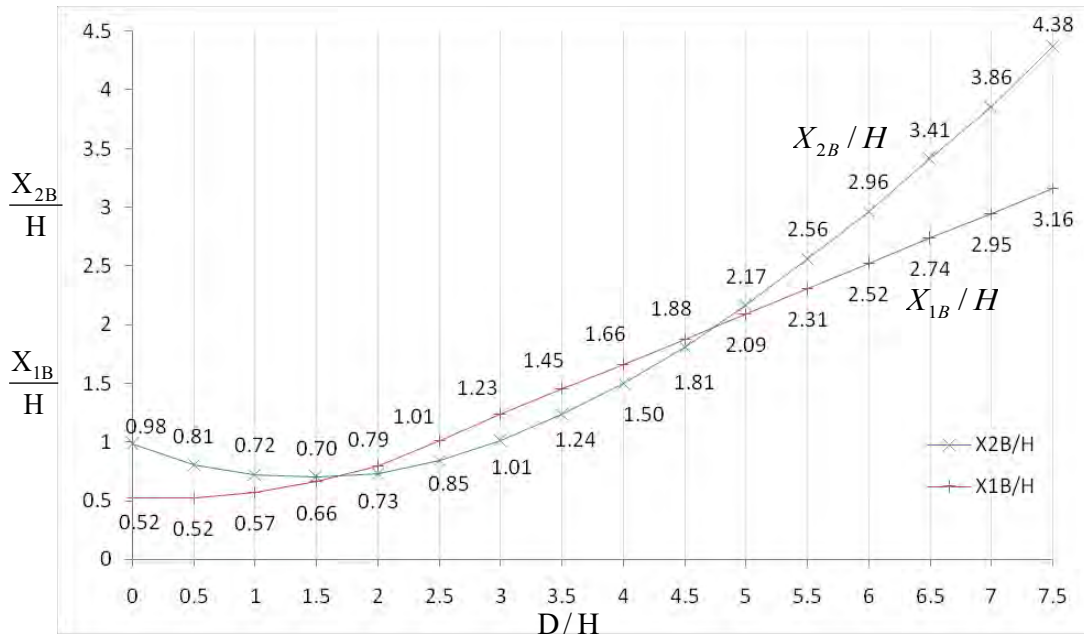

Figure (7-6): Effective weight / height of center of gravity ratio

(Including bottom plate)

- b) Axial stresses σ_{w1} and σ_{w2} under pressure, and allowable buckling stress σ_{cr} of the side plate under dynamic impacts and the liquid sloshing is calculated through the following equations.

$$\sigma_{w1} = \frac{4M_1}{AD} + \frac{W_u}{A} (1 + K_{MV}) - \frac{P_o D}{4t} \quad (\text{N/mm}^2) \quad (7-6)$$

$$\sigma_{w2} = \frac{4M_2}{AD} + \frac{W_u}{A} - \frac{P_o D}{4t} \quad (\text{N/mm}^2) \quad (7-7)$$

$$\sigma_{cr} = \frac{0.25}{1.5} E \frac{t - C}{R} \quad (\text{N/mm}^2) \quad (7-8)$$

M_1 and M_2 are the moments generated in the upper sections of the height, and are calculated through the following Equations.

$$M_1 = M_{Z1} + K_{MH} \times W_u \times X_S \quad (\text{N.mm}) \quad (7-9)$$

$$M_2 = M_{Z2} + K_{M2} \times W_u \times X_S \quad (\text{N.mm}) \quad (7-10)$$

M_{Z1} : Overturning moment by content fluid from the studied height by the upper part at short-period earthquake (N.mm)

M_{Z2} : Overturning moment by content fluid from the studied height by the upper part at long-period earthquake (N.mm)

K_{M2} : Horizontal seismic coefficient of displacement type earthquake ground motion, given by n wave resonance method as follows.

$$K_{M2} = \alpha_2 / g \quad (7-11)$$

$$\alpha_2 = 60\mu_d\beta_1\beta_2 \times (2\pi/T_S)^2 \quad (T_S > 7.5\text{sec} \times \mu_d / \mu_v)$$

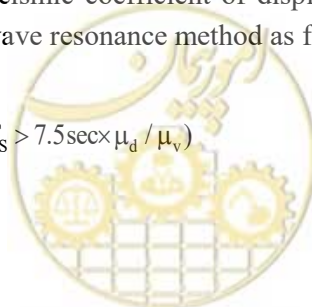

$$\alpha_2 = 50\mu_v\beta_1\beta_2 \times (2\pi / T_s) \quad (T_s < 7.5 \text{sec} \times \mu_d / \mu_v) \quad (7-12)$$

W_u : Weight of tank from studied position to the upper part (N)

X_s : Distance from studied height to center of gravity (mm)

A : Sectional area of side plate in studied height, πDt (mm²)

t : Thickness of side plate in studied height (mm)

C : Corrosion allowance (mm) (The corrosion allowance of the tank on the inside can be assumed 0)

E : Modulus of longitudinal elasticity (N/mm²)

P_0 : Tank internal pressure (MPa)

D : Diameter of tank (mm)

M_{Z1} and M_{Z2} are calculated as follows.

$$M_{O1} = K_{MH} \times W \times X_1 \quad (\text{N.mm}) \quad (7-13)$$

$$M_{O2} = S(n) \times K_{M2} \times W_2 \times X_2 \quad (\text{N.mm}) \quad (7-14)$$

$$M_{Z1} = (1 - Z/H)^2 \times M_{O1} \quad (\text{N.mm}) \quad (7-15)$$

$$M_{Z2} = (1 - Z/H)^{1.3} \times M_{O2} \quad (\text{N.mm}) \quad (7-16)$$

W_1 : Effective weight of content fluid at acceleration type earthquake, and obtained from Fig (7-4) (N)

W_2 : Effective weight of content fluid at displacement type earthquake, and obtained from Fig (7-4) (N)

X_1 : Effective weight height of gravitational center of content fluid at acceleration type earthquake, and obtained from Fig. (7-5) (mm)

X_2 : Effective weight height of gravitational center of content fluid at displacement type earthquake, and obtained from Fig. (7-5) (mm)

$S(n)$: Amplification ratio when sine n wave is input, and $S(n) = 3\pi$

2-Overturning control

Overturning moments M_{1B} and M_{2B} are generated due to the acceleration and displacement caused by the earthquake, and M'_1 and M'_2 are the moments resisting against the overturning moments, which can be calculated through the following Equations.

$$M_{1B} = K_{MH} \times W_1 \times X_{1B} + K_{MH} \times W_T \times X_s \quad (\text{N.mm}) \quad (7-17)$$

$$M_{2B} = S(n) \times K_{M2} \times W_2 \times X_{2B} + K_{M2} \times W_T \times X_s \quad (\text{N.mm}) \quad (7-18)$$

$$M'_1 = (W_L + W_T) \frac{D}{2} (1 - K_{MV}) + \sigma_n \frac{N_B \times A_B \times D}{4} \quad (\text{N.mm}) \quad (7-19)$$

$$M'_2 = (W_L + W_T) \frac{D}{2} + \sigma_n \frac{N_B \times A_B \times D}{4} \quad (\text{N.mm}) \quad (7-20)$$

W_1 : Effective weight of the liquid caused by the acceleration Fig (7-4)

W_2 : Effective weight of the liquid caused by the displacement Fig (7-5)

K_{M2} : Horizontal earthquake coefficient caused by the earthquake displacement, calculated through Equation (7-11)

W_L : Total weight of the liquid (N)

W_T : Weight of the tank main body (N)

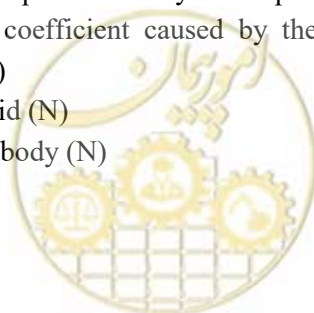

- X_{1B} : Effective weight at the height of the liquid center of gravity caused by the acceleration, Fig (7-6) (mm)
- X_{2B} : Effective weight of the height of the liquid center of gravity caused by the displacement; Fig (7-6) (mm)
- X_S : Height of the studied point from the tank center of gravity (mm)
- N_B : Number of the anchor bolts
- A_B : Sectional area of the anchor bolt (mm^2)
- σ_n : Allowable stress of the anchor bolt (N/mm^2)

3-Strength of the anchor bolts

The stress σ generated due to the load caused by pulling the anchor bolt or strap (hereinafter called the anchor bolt) can be approximately calculated through Equation (7-21).

$$\sigma = \frac{4M_{iB}}{N_B \cdot D \cdot A_B} + \frac{\pi D^2 \cdot P_0}{4N_B \cdot A_B} - \frac{W_T(1 - K_{MV})}{N_B \cdot A_B} + \frac{M_b}{Z_b} \quad (\text{N}/\text{mm}^2) \quad (7-21)$$

K_{MV} : Assumed 0 when the liquid sloshes

M_{iB} : Overturning moment generated due to the seismic impacts at the lower side plate ($i=1,2$)

P_0 : Design pressure (gas pressure) (MPa)

M_b : The bending moment generated per each bolt due to the thermal constriction of the tank (N.mm). When the flexural rigidity of the anchor strap is low, this moment can be disregarded.

Z_b : Sectional modulus of an anchor bolt (mm^3)

K_{MV} : Vertical seismic coefficient (modified)

4-Studying slip of the tank

Generally, the slip strength or the friction force is calculated through multiplying the tank weight by the static friction factor. In this case, the vertical earthquake at the ground level is taken into consideration due to its reductive effect on the tank weight.

Horizontal forces F_1 , F_2 and the strength F_1 , F_2 , caused by the dynamic effects of the earthquake and earthquake displacement are calculated through the following Equations.

$$F_1 = K_{MH}(W_1 + W_T) \quad (\text{N}) \quad (7-22)$$

$$F_2 = S(n) \times K_{M2} \times W_2 + K_{M2} \times W_T \quad (\text{N}) \quad (7-23)$$

$$F_1' = (W_L + W_T) \cdot \mu \cdot (1 - K_{MV}) + \frac{1}{2} T_n \cdot N_B \cdot A_B \quad (\text{N}) \quad (7-24)$$

$$F_2' = (W_L + W_T) \cdot \mu + \frac{1}{2} T_n \cdot N_B \cdot A_B \quad (\text{N}) \quad (7-25)$$

K_{MH} , K_{M2} , W_1 , W_2 , W_T , $S(n)$, N_B , A_B : As defined in the previous equations

T_n : Allowable stress of the anchor bolt (N/mm^2)

μ : Coefficient of friction between bottom of the tank and the foundation

K_{MV} : Horizontal seismic coefficient at the ground level

5-Compression Buckling Control

5-1-Buckling strength of the side plate

The compression stress σ generated due to the seismic load in the side plate of the external tank must be less than the allowable stress σ_c , shown below:

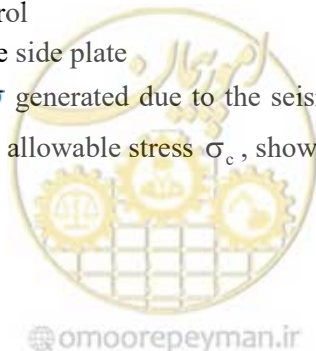

$$\sigma = \frac{N}{A} + \frac{4M_i}{AD} \quad (\text{N/mm}^2) \quad (7-26)$$

$$\sigma_c = \frac{0.2}{1.5} E \frac{t_{as} - C}{R} \quad (\text{N/mm}^2) \quad (7-27)$$

N: Vertical load considering the vertical seismic coefficient (N)

A: Section of the side plat at the studied height (N)

M_i : Buckling moment generated in the side plate due to the seismic load at the studied height

t_{as} : Actual thickness of the side plate of the external tank (mm)

C: Allowable corrosion

5-2-Tank Corrosion

The stress generated due to the seismic force must be less than the allowable stress.

$$\sigma = Q / A_p \quad (\text{N/mm}^2) \quad (7-28)$$

$$Q = F + \frac{4M_o}{D_i N} \quad (\text{N}) \quad (7-29)$$

Q: Load on the anchor (N)

M_o : Overturning moment generated due to acceleration (N.mm)

D_i : Inner diameter of the tank (mm)

N: Number of the anchors

F: Load on the anchor in normal operation conditions (N)

A_p : Sectional aria of the anchor (mm^2)

7-2-2-2- Formable Method Design

In formable method design, strength of each element of the tanks must be as follows:

1-Internal tank

1-1-The design must be performed so that the ductility factor does not exceed the allowable ductility.

1-2-For the evaluation of the inner tank with the predominant of the first mode, the energy method can be applied.

1-3-Evaluation of the seismic performance is conducted in the following damage modes:

a) Side plate of the internal tank

- Plate buckling
- Internal tank anchor
- Anchor yield
- Internal tank spray
- Spray defect

2-External tanks

External tanks are evaluated based on parts (1-1) and (1-2) and based on the following damage modes.

- Buckling of the side plate

3-Pump barrel frame

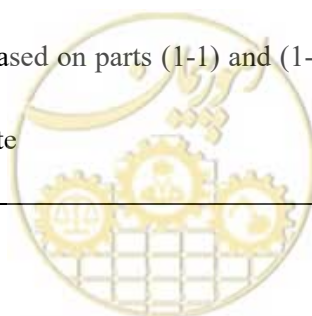

The seismic performance of the roof anchor and the side plates of the internal tank in the pump barrel frame must be performed through a proper method of analyzing the pump barrel frame response.

4-Cold insulation

Shall be designed not to let the seismic stress exceed the allowable stress

Where the ductility factor is not given, flexibility and stress are considered at the yield limit. That is to say the stress is taken the yield stress and the flexibility is taken the yield flexibility. For more explanations about 7-2-2-2 see Appendix 2.

7-2-3- Allowable Quantities

Allowable quantities are given in part (4-3) about the materials.

7-2-4- Judgment Criterion

7-2-4-1- Allowable Stress Method (level-1)

Strength of the tank elements in allowable stress method depends on the following principles.

1-Elements such as side and bottom plates

The stress generated in these elements under level-1 conditions must be smaller than the allowable stress. In the side plates, the axial compression stress must not exceed the allowable buckling stress.

2-Overturning

The overturning moment generated due to the sloshing and acceleration caused by the earthquake must not exceed the resisting moment.

3-Strength of elements such as the anchor bolt

The stress generated in the anchor bolt or strap during the earthquake must not exceed the related allowable stress.

4-Tank slip

The horizontal force caused by the sloshing and acceleration of the earthquake must not exceed the slip strength.

5-Roof strength

The stress generated in sheeting and bone of the roof and the plate around the bottom of the tank due to the seismic load must not exceed the allowable stress.

6-External tank

The stress generated in the side plate of the roof cover, bone, and the anchor due to the earthquake must not exceed the allowable stress.

7-Pump barrel frame

The stress generated in this element during the earthquake must not exceed the allowable stress.

8-Cold insulation

The stress generated due to the earthquake must not exceed the allowable stress

7-2-4-2- Ductility Method (level-2)

Strength of the tank elements in the ductility method is determined considering the following principles.

1-Internal tank

The calculated ductility factor in damage modes under the level-2 must not exceed the

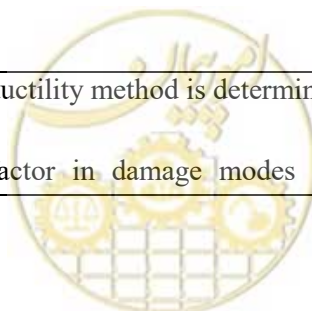

allowable ductility factor.

1-1-Side plate buckling

1-2-Internal tank anchor yield

1-3-Internal tank spray defect

2-External tank

Design method is similar to the part (1), and evaluation of the seismic performance is based on the damage mode of the side plate buckling.



Chapter 8

Seismic design and safety control power plant piping



8-1- Seismic Performance of Piping Systems

The piping system between the equipment shall remain intact and keep operating under level-1 risk conditions. No leakage is expected under level-2 conditions. Potential damages shall be so insignificant that the system can start to operate after minimum stoppage.

- The main piping of the boiler, turbine, and gas & petroleum fuel tanks must be capable of transmitting the earthquake force to the supporting structure.
- The piping between the equipment shall take no damage due to the earthquake acceleration and relative displacement, and the content liquid shall not leak.

8-2- Seismic design of the piping system

8-2-1- Aboveground piping

a) Main piping of the boiler and turbine

Seismic design of the boiler and steam turbine piping must be performed through the equivalent static method.

b) Fuel tank piping

Design of the “very important” pipes is performed through the modified equivalent static method, spectra analysis method, or time history analysis method.

When the proper seismic wave is used, and the proper damping is taken into consideration in the analysis, the time history response analysis method can be used as well.

In piping systems of average or low importance, when the design is performed through piping support response analysis method (simplified seismic performance evaluation), there is no need to analyze the response and the response displacement.

Following issues must be taken into consideration in the seismic design:

1-The modified equivalent static method

1-1-In the modified equivalent static method, the pipe is modeled considering the beam behavior and the related support conditions.

1-2-Required flexibility must against displacement of supporting structure, tank, or machinery shall be provided.

1-3-Stress of the supporting mesh (including the anchor bolt) under the reaction at the supporting point must be controlled.

2-Dynamic method

2-1- In the dynamic method, modeling must comply with the real conditions.

2-2- If the weight of the piping system is low enough (less than 10% of the system weight), compared to the weight of the supporting structure (or the tank, or the machinery), the seismic force is calculated through part (2-3) or (2-4).

2-3- When the natural frequency of the piping system is extremely higher than the dominant natural frequency of the supporting structure (more than 10 times), the seismic force is calculated through multiplying the mass by the maximum response acceleration of the piping system at the studied point.

2-4- In cases other than part (2-3), the seismic force is calculated considering the dynamic

behavior of the piping system.

2-5- If weight of the piping system cannot be disregarded, compared to the weight of the supporting structure (less than 10% of the weight of the supporting system), the piping system and the supporting structure are analyzed as a compound system.

- Damping constant of the piping assumed 5% or less.
- For dynamic design method, the design force must be calculated using the response spectra of the bottom of the supporting structure.

8-2-2- Underground Piping

Seismic design of the underground piping systems is preferably performed through displacement response analysis method.

Evaluation of the underground pipes of high or very high importance category is based on the strain generated in the pipe. In areas, where there is a potential of large displacements due to the liquefaction, and large horizontal displacement due to the lateral movement of the sloped ground, proper studies are required.

8-3- Calculations of Piping System in Boiler and Steam Turbine

1-Main boiler piping

1-1-When the seismic force is applied, the generated stress shall comply with Equations (8-1) and (8-2).

$$S_L = \frac{PD_0}{4t_n} \left(\text{or } \frac{Pd^2}{D_0^2 + d^2} \right) + \frac{1000(0.75 \times i_c)M_A}{Z} \leq 1.0S_h \quad (8-1)$$

$$S_L = \frac{PD_0}{4t_n} \left(\text{or } \frac{Pd^2}{D_0^2 + d^2} \right) + \frac{1000(0.75 \times i_c)M_A}{Z} + \frac{1000(0.75 \times i_c)M_B}{Z} \leq 1.2 \times S_h \quad (8-2)$$

S_L : Stress generated due to internal pressure, weight of pipes, and other operation loads (N/mm²)

P : Design pressure (MPa)

D_0 : Outer diameter of pipe (mm)

d : Inner diameter of pipe (mm)

Z : Modulus of sections (mm³)

M_A : Combined moment generated by the weight of pipe along the section, and other operation loads (N.m)

i_c : Stress concentration factor

M_B : Combined moment generated by variable loads such as safety valve jet reaction force in the pipe section, pressure, fluctuation of the flow rate and seismic force.(N.m)

S_h : Allowable stress strength of the material in design temperature (N.mm²)

1-2-When the stress generated by the relative displacement is taken into consideration, Equation (8-3) shall apply.

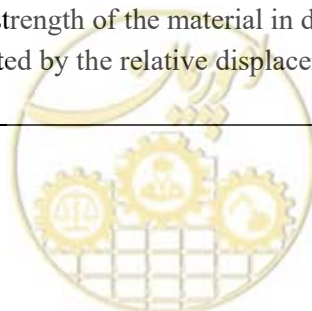

$$S_E = \frac{1,000(i_c \cdot M_C)}{Z} \leq S_A + S_h - S_L \quad (8-3)$$

S_E : Stress generated in pipe by load (N/mm²)

M_C : Combined moment generated due to the relative displacement caused by the earthquake and thermal expansion between the joints (N.m)

S_A : Assumed $1.25S_c + 0.25S_h$

S_C : Allowable tensile strength of materials in normal temperature (N.mm²)

2-Main turbine piping

It is preferable to design the main and secondary pipes of the turbine based on the following concerns:

2-1-Main pipes

Joints of the main turbine pipes must be designed through the same method used for the main boiler pipes. The main pipes are:

- a) Pipes connecting the steam valve to the main body
- b) Pipes connecting the medium pressure turbine to the low pressure turbine

2-2-Secondary pipes

Include pipes brining the seawater to the condenser, cooler, and heat exchanger, except those of small diameter. Unprotected secondary pipes must be designed to endure the seismic force. The pipeline is expected to show a large relative displacement along the route, and shall be anchored properly, as per judged by the designer. The supporting points above the joints must be designed carefully.

- Main boiler pipes include the main steam pipe, the open heater pipe with high and low temperature, and the main water pipe.
- Lots of damages to the main boiler piping in an earthquake are sources in the relative displacement of the supporting structure. Therefore, the support displacement must be taken into consideration in the seismic design.
- To avoid amplification of the vibrations, natural period of pipes and supports must be taken into consideration.

Seismic force of the main boiler pipes is calculated using the modification factor related to the height, or assuming constant average values, as the installation height range varies.

In the study, the relative displacement between the joints of the main boiler piping, and the relative displacement between the boiler building and the turbine building must be taken into consideration. The relative displacement is calculated through Equation (8-4).



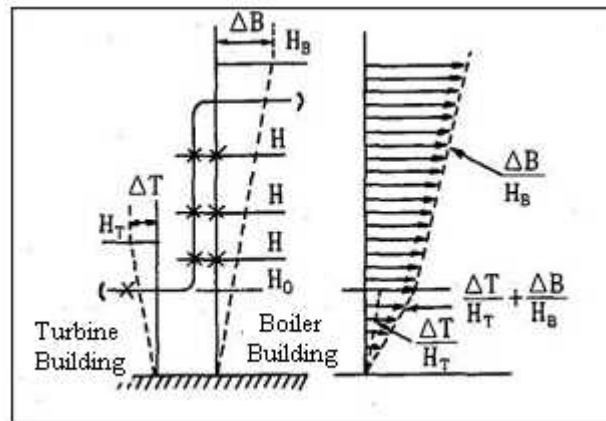

Figure 8-1: Relative displacement between boiler building and turbine building

$$\Delta = \left(\frac{\Delta T}{H_T} + \frac{\Delta B}{H_B} \right) H_0 + \frac{\Delta B}{H_B} (H - H_0) \quad (8-4)$$

Δ : Relative displacement (mm)

ΔT : Displacement of turbine building (mm)

ΔB : Displacement of boiler building (mm)

H_T : Height of the turbine building (m)

H_0 : Height of the closest boiler piping / boiler building connection (m)

H : Height of the closes point of displacement calculation

When the values of T and B are not given, the value in parentheses in the first sentence of Equation (8-4) can be assumed 100mm/30m, and $\frac{\Delta B}{H_B}$ of the second sentence can be assumed 160mm/60m.

Coefficient f is assumed 1, because the normal start/stop frequency of a power plant is 7000 bars or less. Seismic design evaluation of the main boiler piping is performed in accordance with ASME - B31.1 - 2001 EDITION.

The sentence in parentheses in Equations (8-4) and (8-5) is used for the tick pipes and in accordance with part III of ASTM.

Steam turbine piping: Seismic design of the steam turbine piping is performed through the same method used for seismic design of the main boiler piping.

8-4- Calculations of Fuel Tank Piping

1-General

The following loads must be taken into consideration as the effective loads in seismic design.

- Weigh of the pipes and accessories
- Weight of the content
- Internal pressure of the piping
- Seismic effects
- Other loads

The design stress is the sum of stresses caused by the operation load and the seismic load under the most unfavorable conditions.

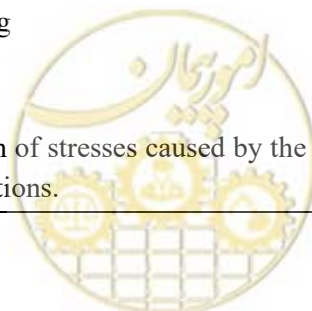

The major concerns of seismic design are:

- 1-1-The design calculations are based on shape and material of the structure and the category of operation conditions. Vibration state of the other pipes can be estimated through the results of the related calculations and there's no need to do the seismic calculations separately.
- 1-2-The piping system is modeled in form of a beam and supporting conditions.
- 1-3-When there is fear of a large displacement resulting in stress generation, the piping must be adequately flexible.
- 1-4-To avoid the supporting structure sink, the required equipment shall be used.
- 1-5-The stress caused by the relative displacement between fixing points, such as supporting structure, tank, and machinery, must be checked.
- 1-6-To avoid damages and leakage, the joint between the pipe and the tank must be capable of absorbing the potential relative displacements.

2-Stress calculation in normal operation conditions

- 2-1-The circumferential stress generated due to the internal pressure of the piping is calculated through Equation (8-5).

$$\sigma_{ci} = \frac{P_i(D-t+c)}{2(t-c)} \quad (8-5)$$

σ_{ci} : Circumferential stress generated due to the internal pressure of piping (N/mm²)

P_i : Maximum operation pressure (MPa)

D : Outer diameter of the piping (mm)

t : Real thickness of the pipes (mm)

c : Thickness of the inner surface corrosion (mm)

- 2-2-The circumferential stress generated in the piping due to the ground pressure, or train/vehicle load is calculated through Equation (8-6).

$$\sigma_{CO} = \frac{D_1 \cdot K_B \cdot W \cdot R \cdot E \cdot I_t + \alpha \cdot W \cdot K_{HS} \cdot R^5 + 2\beta \cdot D_1 \cdot K_x \cdot W \cdot P_i \cdot R_4}{E \cdot I_t + 0.061 K_{HS} \cdot R^4 + 2P_i \cdot D_1 \cdot R^3 \cdot K_x} \cdot \frac{1}{Z_t} \quad (8-6)$$

σ_{CO} : The circumferential stress generated in the piping due to the ground pressure or train/vehicle load (N/mm²).

D_1 : Uplift coefficient related to the time (1 for ground type I, and 1.5 for other ground types)

K_B : Value calculated through Table (8-1)

Table 8-1: K_x and K_B considering the ground conditions

| Ground Conditions | K_B | K_x |
|---------------------|-------|-------|
| Adequately condense | 0.125 | 0.083 |
| Normal | 0.138 | 0.089 |

W : Ground pressure or train/vehicle load (N.mm)

R : Radius of the pipes (mm)

E : Young's modulus of piping (N.mm²)

I_t : The second moment of the pipe wall surface (Fig. 5-34) (mm⁴/mm)

α : Value calculated through Equation (7-8)

$$I_t = \frac{1}{12} t^3 \quad (\text{mm}^4 / \text{mm}) \quad (8-7)$$

$$Z_t = \frac{1}{6} t^2 \quad (\text{mm}^3 / \text{mm}) \quad (8-8)$$

$$\alpha = 0.061 \times D_1 \times K_B - 0.082 \times K_x \quad (8-9)$$

K_{HS} : Coefficient of horizontal response (N/mm^2)

β : Value calculated through Equation (8-8)

$$\beta = D_1 \times K_B - 0.125 \quad (8-10)$$

P_i : Maximum operation Pressure (Mpa)

K_x : Value calculated through Table (8-1)

Z_t : Modulus of the pipe wall section (Fig. 8-2) (mm^3/mm)

I_t, Z_t : Calculated through Equations (8-9) and (8-10)

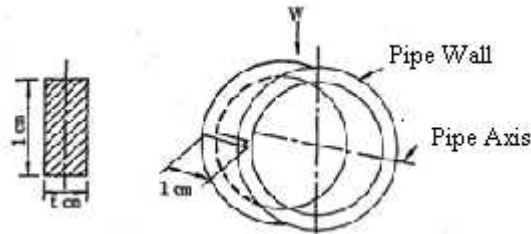

Figure 8-2: Pipe section

When the axial displacement is not limited, the axial stress generated in the piping due to the internal pressure is calculated through Equation (8-11); when the axial displacement is limited, it is calculated through Equation (8-12).

$$\sigma_{li} = \frac{P_1(D-t+c)}{4(t-c)} \quad (8-11)$$

$$\sigma_{li} = v \cdot \frac{P_1(D-t+c)}{2(t-c)} \quad (8-12)$$

σ_{li} : Axial stress caused by the internal pressure of the piping (N/mm^2)

P_1 : Maximum operation pressure (MPa)

v : Poisson's coefficient of piping

2-3-The axial stress generated in the piping due to the ground pressure or the train/vehicle load is calculated through Equation (8-13)

$$\sigma_{10} = \frac{0.322W}{Z_p} \cdot \sqrt{\frac{E \cdot I_p}{K_{SV} \cdot D}} \quad (8-13)$$

σ_{10} : Axial stress generated in the piping due to the ground pressure or train/vehicle load (N/mm^2)

W : Train/vehicle load (N/mm)

- Z_p : Modulus of pipe section (mm^3)
 E : Young's modulus of piping (N/mm^2)
 I_p : Second moment of piping surface (mm^4)
 K_{SV} : Vertical coefficient of response (N/mm^3)

3-Method of stress calculation during the earthquake

The earthquake effects include inertia force, ground pressure, hydrodynamic pressure, and ground movements caused by the earthquake.

3-1-For aboveground piping

a)Inertia force

The inertia force is applied vertically on the horizontal axis of the pipe.

b) Hydrodynamic pressure

Hydrodynamic pressure during the earthquake is calculated through Equations (8-14) and (8-15).

$$P_{W1} = 0.785 \times K_{SH} \times \gamma_w \times D^2 \quad (8-14)$$

$$P_{W2} = 0.785 \times K_{SV} \times \gamma_w \times D^2 \quad (8-15)$$

P_{W1} : Horizontal hydrodynamic pressure caused by the earthquake (N/m)

P_{W2} : Vertical hydrodynamic pressure caused by the earthquake (N/m)

γ_w : Special weight of the water (N/m^3)

Direction of P_{W1} is the horizontal direction perpendicular to the pipe axis, and direction of P_{W2} is the vertical direction perpendicular to the pipe axis parallel to the inertia force.

3-2- Underground piping

a)Ground pressure

Ground pressure during the earthquake is calculated through Equation (8-16). Ground pressure in shored piping is calculated through Equation (8-17).

$$W_s = \gamma_s \times h \times D \times (1 + K_v) \quad (8-16)$$

$$W_s = \frac{1}{K} \cdot (e^{\frac{K_h}{D}} - 1) \cdot \gamma_s \cdot D^2 (1 + K_v) \quad (8-17)$$

W_s : Ground pressure (N/mm)

γ_s : Wet density of soil (N/mm^3)

h : Depth of the piping (mm)

e : Natural logarithm

K : Constant; 0.4 for soil type I and II, and 0.8 for other soil types

K_v : Vertical earthquake coefficient at the ground level

The concerned loads are:

1-Internal pressure is considered the maximum internal pressure.

2-Ground pressure is the pressure of the soil layer covering the pipe.

3-Hydraulic pressure is assumed equal to the hydrostatic pressure.

4-Train load is calculated through Equation (8-18). When two trains pass at the same time, load of each train is calculated separately.

$$W_t = \frac{P_t \cdot D}{B_t (B_s + 2h_p \cdot \tan\theta)} \cdot (1 + i_t) \quad (8-18)$$

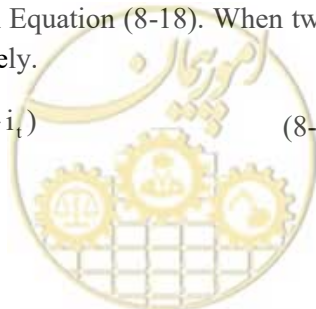

- W_t : Train load (N/mm)
 P_t : Axis load (wheel) (N)
 B_t : Width of the wheel (mm)
 B_s : Length of the traverse (mm)
 h_p : The distance between the upper surface of the pipe and the ground level (mm)
 θ : Load distribution angel (wheel) (degree)
 i_t : Impact coefficient taken from Table (8-2)

Table 8-2: Train impact coefficient

| Impact Coefficient (i_t) | h_p (mm) |
|------------------------------|---------------------------|
| 0.75 | $h_p < 1500$ |
| $0.9 - 0.0001h_p$ | $1500 \leq h_p \leq 9000$ |
| 0 | $9000 < h_p$ |

5-Vehicle load is calculated through Equation (8-19)

$$W_m = \frac{29.1D}{100 + h_p \cdot \tan \theta} \cdot (1 + i_c)(N/mm) \quad (8-19)$$

- W_m : Vehicle load (N/mm)
 θ : Load distribution angle f the rare wheel (degree)
 i_c : Impact coefficient, taken from Table (8-3)

Table 8-3: Vehicle Impact Coefficient

| Impact Coefficient (i_c) | h_p (mm) |
|------------------------------|---------------------------|
| 0.75 | $h_p < 1500$ |
| $0.65 - 0.0001h_p$ | $1500 \leq h_p \leq 6500$ |
| 0 | $6500 < h_p$ |

8-5- Piping System Calculations for Liquefied Natural Gas Tanks

8-5-1- Evaluation Procedure

In structures of the low importance category there's no need for the seismic design and the system is designed through simplified methods of piping support evaluation (allowable pipe span method). The seismic design is required for the following pipes:

- Pipes with outer diameter of 45mm and above
- Pipes with content of $3m^3$ and above
- Pipes connected to the towers and tanks



8-5-2- Simplified Method

This method can be used in structures of medium or low importance category. In this method if the length of the pipe span is smaller than the allowable pipe span, and displacement absorption capacity of the support is bigger than the relative displacement of the structure, the seismic performance is acceptable.

Allowable span method is used in the following cases:

- 1-Performance evaluation is required at each piping section between two fix supports. But, if the piping section is not shown, the evaluation shall be performed at the first support close to the used section.
- 2-The following spans are evaluated through allowable span method.
 - Longest span of the piping system
 - Pipe span with concentrated load
- 3-When there are numerous supports, the relative displacement absorption capacity must be evaluated.
- 4-When the piping spans have extensions, and the outer diameter of the extended pipe is half or less than half of the outer diameter of the main pipe, the evaluation must start from the point of extension and continue to the first support of the extended pipe.
- 5-Evaluation of items 2-4 is performed in all three directions (two horizontal, and one vertical).
- 6-When the piping span has two expansion joints; the displacement capacity of the related joints must be evaluated as well.

8-5-2-1- Allowable Span Criterion

The pipes must be anchored against the earthquake in three directions; two vertical directions, and one direction parallel to the piping axis.

Length of the pipe between two neighboring supports (span length), which provide effective support in direction of the earthquake, shall not exceed the length of the related span.

Judgment criterion of the allowable span method is shown in Equation (8-20)

$$L_{ps} \leq L_a \quad (8-20)$$

L_{ps} : Length of the piping span, calculated in Appendix (3-1) (m)

L_a : Allowable length of the piping span, calculated in Appendix (3-1) (m)

8-5-2-2- Displacement Capacity

Relative displacement of the piping between the supports shall not exceed its displacement capacity.

When there are numerous supports, displacement capacity evaluation is required.

When the piping span has extensions, and the outer diameter of the extended pipe is half or less than half of the diameter of the main pipe, evaluation shall start from the point of extension and continue to the first support.

Evaluation of the displacement capacity is performed as follows:

$$\Delta \leq \delta_a \quad (8-21)$$

Δ : Relative displacement between two supports or between the point of extension and the first support (mm)

δ_a : Displacement capacity of the piping span in the design direction (mm)

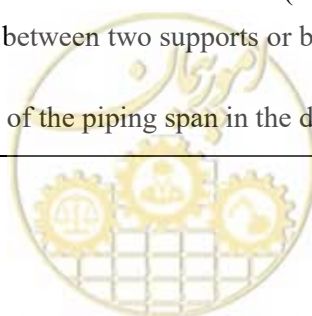

8-5-3- Allowable stress method

Seismic performance of the piping system of high importance category is evaluated through allowable stress method, using descriptive analysis. When, the allowable span method cannot be used, the allowable stress method is used even in the low importance category.

Standard seismic design procedure of the piping system is shown in Appendix (3-2).

- 1-The piping system consists of pipes, supports, foundation, flange joints, valves, and expansion joints.
- 2-The seismic wave is transmitted through the foundation to the piping, supports, and the pipes. Pipe vibration spreads through the supports to the supporting structure, and then to the foundation and the ground. To simplify the procedure, usually responses of the supporting structure and the pipe are analyzed separately.
- 3-Response of the supporting structure is analyzed considering only mass of the pipe against the earthquake wave; acceleration and displacement are calculated in the support design.
- 4-Acceleration and displacement calculated through supporting structure response analysis are assumed the input values, based on which the response force, moment, and stress of every section of the pipe, supporting structure, etc. are calculated.
- 5-Seismic performance is analyzed through comparing the calculated stress and the allowable stress of the seismic design.

8-5-3-1- Supporting structure response analysis

Horizontal seismic coefficient and displacement of the support are calculated using the supporting structure response analysis.

In analysis of the supporting structure response, rigidity of the pipe is disregarded and weight of the piping is considered the only load on the supporting structure. Details of the supporting structure response analysis are given in Appendix (3-3).

8-5-3-2- Piping system response analysis

Piping system stress is calculated for static seismic force, support structure displacement response, pressure, and the driving weight.

The analysis is performed through modeling the pipes in form of beams. The modified seismic force is calculated through Equations (8-20) and (8-21).

$$F_{MH} = \beta_8 \mu K_{MH} W_H \quad (8-22)$$

$$F_{MV} = \beta_9 K_{MV} W_V \quad (8-23)$$

F_{MH} : Modified design horizontal seismic force (N)

F_{MV} : Modified design vertical seismic force (N)

β_8 : Magnification coefficient of the horizontal response (Table 8-4); when the supporting structure connected to the tower/tank piping is of the frame type, the value stated in this table is multiplied by 2. This coefficient for supporting structure of piping is 2.

β_9 : Magnification coefficient of the vertical response of the supporting structure, which is assumed 2

K_{MH} : Modified coefficient of horizontal earthquake

K_{MV} : Modified coefficient of vertical earthquake

$$K_{MH} = \beta_5 K_H \quad (8-24)$$

$$K_{MV} = \beta_6 K_V \quad (8-25)$$

β_5 : Response amplification, which is assumed 2 in this equation

β_6 : Response amplification in vertical direction, which is assumed 2 in this equation

W_H : Weight of the driving element (N)

W_V : Weight of the content and dead weight of the piping, where the modified design vertical seismic force is calculated (N)

- Piping system response is analyzed based on the supporting structure displacement, and through displacement response analysis method.
- In this method displacement response of the supporting structure, is regarded as the compulsory displacement of the pipes and accessories.
- Analytical model and modified design seismic force are shown in Appendix 3-4.

8-5-3-3- Piping Stress Calculation

The longitudinal stress of the pipe, caused by the seismic force, liquid pressure, and driving weight, is calculated through combining the operation load and the earthquake load.

1-Liquid pressure, driving weight, and seismic force

The longitudinal stress caused by the liquid pressure, driving weight, and horizontal and vertical seismic forces for curved sections, extensions, and supporting sections is calculated through Equation (8-26).

$$\sigma_\ell = \frac{\sqrt{(i_i M_i)^2 + (i_o M_o)^2}}{Z} + \left| \frac{F_T}{A_p} \right| \quad (8-26)$$

σ_ℓ : Longitudinal stress generated by pressure, weight, and earthquake force (N/mm²)

i_i : In-plate stress amplification coefficient, calculated through any proper method based on type of the joint (Table 19)

i_o : Off-plate stress amplification coefficient, calculated through any proper method based on type of the joint (Table 19)

M_i : In-plate bending moment generated by the liquid pressure, driving weight, and horizontal & vertical seismic force (Appendix 3-5) (N.mm)

M_o : Off-plate bending moment generated by the liquid pressure, driving weight, and horizontal & vertical seismic force (Appendix 3-5) (N.mm)

Z : Modulus of the pipe section, in which the allowable corrosion is disregarded in calculations. For extensions of various diameters Equation (8-27) can be used (mm³)

$$Z = \pi(r_p)^2 t_s \quad (8-27)$$

r_p : Average radius of the pipe at the curving point (mm)

t_s : Effective thickness of the pipe at the curve; allowable corrosion thickness and the support plat are disregarded (mm)

F_T : Axial force generated by the liquid pressure, driving weight, and horizontal and vertical

seismic forces on the piping (N)

A_p : Pipe sectional area; allowable corrosion is disregarded (mm^2)

2-Frequent stress range based on the seismic force

Range of the frequent stress is calculated based on design horizontal and vertical seismic forces, and displacement of the piping support, through Equation (8-28).

$$\sigma_E = 2 \frac{\sqrt{(i_i M_i)^2 + (i_o M_o)^2 + M_t^2}}{Z} \quad (8-28)$$

σ_E : Range of the frequent stress of the bending stress based on horizontal and vertical seismic forces, and displacement of the piping support (Appendix 3-5) (N.mm)

M_t : Torsion moment generated by the horizontal and vertical seismic forces, and displacement of the piping support (Appendix 3-5) (N.mm)

8-5-3-4- Piping Stress Evaluation

In seismic design, if the calculated stress does not exceed the allowable stress, the evaluation is acceptable.

If the calculated stress is bigger than the allowable stress, structure and supporting conditions are changed and performance evaluation is repeated.

The allowable design stress of the piping is shown in Appendix 3-6.

8-5-3-5- Flange joint performance evaluation

- The leakage caused by the axial force and the bending moment calculated through acceleration response analysis and displacement response analysis must be measured around the flange joints.
- Leakage evaluation is approved when the stresses at the flange joint (radial and circumferential stresses of the flange and axial stress of the pipe) are smaller than the allowable stress.
- Seismic performance of the flange joints of the low importance category may be disregarded.

1-Total equivalent pressure calculation

Internal pressure P_e generated by the axial tensile force F_T (N), and the bending moment M (N.mm) generated by the seismic load are calculated through Equation (8-29).

$$P_e = \frac{4F_T}{\pi D_e^2} + \frac{16M}{\pi D_e^3} \quad (8-29)$$

P_e : Equivalent pressure during the earthquake (MPa)

F_T : Axial tensile force caused by the earthquake (N)

M : Bending moment (N.mm)

D_e : Average diameter of the gasket contact side (mm)

$$D_e = D_{gi} + 2(N_g - b_g) \quad (8-30)$$

D_{gi} : Inner diameter of the gasket

N_g : Width of the gasket

b_g : Effective width of the gasket

The total equivalent pressure P_{eq} is calculated through Equation (8-31) and using the liquid pressure P_p and the equivalent pressure.

$$P_{eq} = P_p + P_e \quad (8-31)$$

P_{eq} : Total equivalent pressure (MPa)

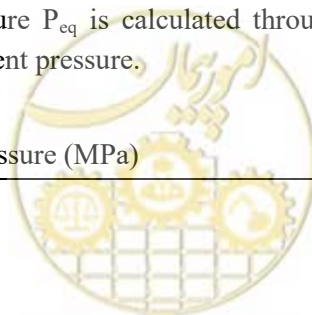

P_p : The liquid pressure in the pipe (MPa)

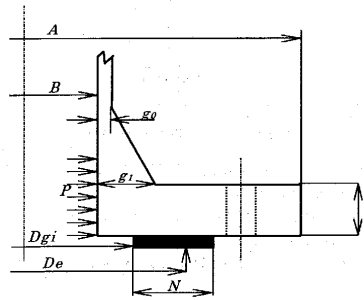

Figure 8-3: Flange with flat gasket

2-Stress calculation (all the stresses shown in N/mm^2)

Stress of the flange joint is calculated in operation conditions.

The total equivalent load is used to calculate the load on the inner diameter of the flange, caused by the total load H and internal pressure. The inner pressure is used only to study the load on the tensile diameter, where the gasket load capacity is reduced in the compression load calculations. Stress of various types of flange, such as loose type flange without hub is, is calculated through the following Equation.

- Axial stress of the hub

$$\sigma_H = 0 \quad (8-32)$$

- Radial stress of the flange

$$\sigma_R = 0 \quad (8-33)$$

- Hoop stress of the flange

$$\sigma_T = \frac{YM}{t_f^2 B_f} \quad (8-34)$$

- Stress of the flange, considering the hub, is calculated through the following equations.

- Axial stress of the hub

$$\sigma_H = \frac{fM}{Lg_1^2 B_f} \quad (8-35)$$

- Radial stress of the flange

$$\sigma_R = \frac{(133t_e + 1)M}{Lg_1^2 B_f} \quad (8-36)$$

- Hoop stress of the flange

$$\sigma_r = \frac{YM}{t_f^2 B_f - Z\sigma_R} \quad (8-37)$$

B_f : Inside diameter of flange. However, B_1 can be used instead of B_f when B_f is smaller than $20g_1$ in the calculation type of the axial stress of the hub.

B_1 : $B_f + g_0$ of the all-in-one design flange and $B_f + g_1$ (mm) at the loose type flange.

d : Coefficient, for the integral shape flange, and arbitrary type flange calculated as a integral shape flange, $\frac{U}{V} h_o g_o^2$, and for the loose type flange, $\frac{U}{V_L} h_o g_o^2$

e : Coefficient, for the integral shape flange, and arbitrary type flange calculated as a integral shape

flange, $\frac{F}{h_o}$, and for the loose type flange, $\frac{F_L}{h_o}$

f: Hub stress modified coefficient decided depending on the value of g_1/g_0 and h_h/h_0 , refer the chart in Appendix 3-7

F: Coefficient decided depending on the value of g_1/g_0 and h_h/h_0 , refer the chart in Appendix 3-7

F_L: Coefficient decided depending on the value of g_1/g_0 and h_h/h_0 , refer the chart in Appendix 3-7

h_h : Length of hub (mm)

h_0 : 0 Bg (mm)

g_0 : Thickness of hub point (mm)

g_1 : Thickness of hub of flange back face (mm)

L: Coefficient equal to $(t_e + 1) / T + t_f^3 / d$

M: Moment acts on the flange, considered the equivalent all pressure by the seismic force. (N.mm)

T: Coefficient decided depending on the value of $K (=A/B_f)$, refer the chart in Appendix 3-7

t_f : Thickness of flange (mm)

U: Coefficient decided depending on the value of $K (=A/B_f)$, refer the chart in Appendix 3-7

V: Coefficient decided depending on the value of g_1/g_0 and h_h/h_0 , refer the chart in Appendix 3-7

VL: Coefficient decided depending on the value of g_1/g_0 and h_h/h_0 , refer the chart in Appendix 3-7

Y: Coefficient decided depending on the value of $K (=A/B_f)$, refer the chart in Appendix 3-

Z: Coefficient decided depending on the value of $K (=A/B_f)$, refer the chart in Appendix 3-7

Leakage evaluation is performed through calculation of internal stress, equal to the seismic load (hereinafter called "equivalent internal pressure"), and the stress generated at the flange joint (radial stress at the wing, circular stress at the wing, and axial stress at the center) caused by the equivalent pressure, which is added to the equivalent internal pressure, must be smaller than the allowable design stress.

8-5-3-6- Seismic performance evaluation of valves

- The stress in the weakness part between the main body of valve and the weight parts at the eccentricity position from the piping center of axle is calculated to inertia force by the earthquake motion. If strength is secured, then it is considered that the block performance of the valve is secured.
- The stress in the weakness part between the main body of valve and the weight parts at the eccentricity position from the piping center of axle is calculated to inertia force by the earthquake motion. If strength is secured, then it is considered that the block performance of the valve is secured.
- As for the following valves, the evaluation by the calculated stress is omissible.
 - When the piping system that contains the valve by the allowable span method of the convenient seismic design method is designed
 - When the eccentricity weight part such as actuators is supported
 - When the natural frequency of the valve by 3) is 20Hz or more.
- Judgment of natural frequency of valve

The natural frequency of the valve when $\frac{H_{VD}}{\sqrt{D_v}} \leq 40$ can be considered to be 20Hz or more.

H_{VD} : Distance to center of gravity from the bonnet flange side of the valve to the

eccentric weight part such as driving parts (mm).

D_V : Minimum width of material in eccentric weight part such as bonnet flange sides and driving parts of valve (mm)

However, a manual valve is assumed to be 20Hz regardless of the above-mentioned.

1-The design modified horizontal seismic force

The design modified horizontal seismic force that acts on the valve is calculated through Equation (8-38).

$$F_{MH} = \beta_8 \mu K_{MH} W_H \quad (8-38)$$

However, when the valve stem direction is perpendicular to vertical direction of the earthquake, the design force is calculated through the following equation instead of the above equation.

$$F_{MH} = \beta_9 K_{MV} W_H \quad (8-39)$$

F_{MH} : Design modified horizontal seismic force of valve (N)

β_8 : Horizontal response magnification factor (Table 8-4); when the supporting structure is connected to the tower/tank piping is of the frame structure type this value is multiplied by 2. This factor is assumed 2 for the supporting structure of the piping.

Table 8-4: Response Magnification Factor of Valve

| $H_{VD} / \sqrt{D_V}$ | Multiplier β_8 |
|-----------------------|--|
| 40 or less | 1.0 (However, evaluation is omissible) |
| 40-60 | $0.1H_{VD} / \sqrt{D_V} - 0.3$ |
| More than 60 | 4 |

β_9 : Response magnification factor of the valve; its value is assumed 1-3, and shall be multiplied by 2, which is the defined response magnification factor of the piping based on the valve supporting structure and method.

W_H : Weight of eccentric weight parts such as driving parts of valve (N)

2-Stress calculation

Stress of the eccentric weight parts and driving parts of the valve is calculated through Equation (8-40).

$$\sigma_n = \frac{F_{MH} \cdot L_b}{Z} + \sigma_L \quad (8-40)$$

σ_n : Largest stress caused in the section between eccentric weight parts such as valve main bodies and driving parts (N/mm²)

F_{MH} : Design modified horizontal seismic force of valve (N)

L_b : Distance from the center of gravity of the members, between weighting parts and actuators to the eccentric weight parts (mm)

Z : Modulus of sections (mm³)

σ_L : Stress generated in section by inner pressure and driving force (N/mm²)

when the section of member is in form of a cylinder, the internal pressure is applied to the valve main body, the valve stem is driven to the axial direction, and the output from the actuator joins the axial direction of the valve stem, the valve stress is calculated through Equation (8-41).

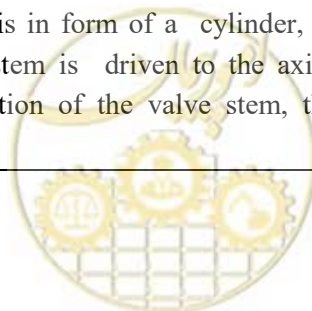

$$\sigma_L = (F_p + F_m) \cdot \frac{4}{\pi(D_o^2 - D_i^2)} \quad (8-41)$$

F_p : Force generated by inner pressure (N)

$$F_p = \frac{\pi D_i^2}{4} \cdot P_p \quad (8-42)$$

F_m : Output force from driving part (N)

D_i : Inside diameter in section (mm)

P_p : Pressure of fluid in valve main body (MPa)

- In a valve whose driving part is weighty enough and its center of gravity is far from the piping axis, due to the relative reduction of the natural frequency, a large force is generated in the driving part during the earthquake.
- For valves with natural frequency of less than 20 hertz, the stress is measured in the weak part between the main body and eccentric weight parts of the piping axis, to calculate the inertia force and evaluate the seismic performance.
- If the strength is large enough, the interception performance may be assumed safe.

8-5-3-7- Seismic performance evaluation of expansion joint

1-Stress calculation

1-1-Axial movement of bellows mountain

Axial movement of the bellows mountain, caused by the earthquake, is converted to the axial movement of the mountain as follows:

$$e_{be} = e_x + e_y + e_\theta \quad (8-43)$$

a) For single bellows

$$e_x = \frac{x}{N_b} \quad (8-44)$$

$$e_y = \frac{3d_p y}{L_{lb} + x_c} \quad (8-45)$$

$$e_\theta = \frac{d_p \theta_A}{2N_b} \quad (8-46)$$

b) For double bellows

$$e_x = \frac{x}{2N_b} \quad (8-47)$$

$$e_y = \frac{K_{bl} d_p y}{2N_b (L_{lb} - C_{bl} + 0.5x_c)} \quad (8-48)$$

e_{be} : Amount of bellows of every mountain movement (mm)

x : All axial displacements (mm)

y : Amount of all axis right-angled direction displacement (mm)

A_T : Amount of all axes bends displacement (rad)

x_c : Amount of shrinking side axis direction displacement (mm).

N_b : Number of mountains of bellows of 1 piece

D_p : Average diameter of bellows (mm)

L_{lb} : Effective length of bellows part (mm)

C_{bl} : Effective length of one bellows (mm)

K : Equivalent movement modified coefficient of double bellows

1-2-Stress Calculation (all the stresses are in N/mm^2)

a) For bellows without reinforcement ring

I. Axial membrane stress caused by pressure

$$\sigma_{mmp} = \frac{P_p W_b}{2n_b t_p} \quad (8-49)$$

II. Axial bending stress caused by pressure

$$\sigma_{mbp} = \frac{P_p}{2n_b} \left(\frac{W_b}{t_p} \right)^2 C_p \quad (8-50)$$

III. Axial membrane stress caused by every mountain movement

$$\sigma_{mmd} = \frac{E'_b t_p^2}{2W_b^3 C_f} e_{ba} \quad (8-51)$$

VI. Axial bending stress caused by every mountain all movement

$$\sigma_{mbd} = \frac{5E'_b t_p}{3W_b^2 C_d} e_{ba} \quad (8-52)$$

b) For bellows with reinforcement ring

i) Axial direction membrane stress caused by pressure

$$\sigma_{mmp} = \frac{P_p (W_b - k_r q)}{2n_b t_p} \quad (8-53)$$

ii) Axial bending stress caused by pressure

$$\sigma_{mbp} = \frac{P_p}{2n_b} \left(\frac{W_b - k_r q}{t_p} \right)^2 C_p \quad (8-54)$$

iii) Axial membrane stress caused by every mountain all movement

$$\sigma_{mmd} = \frac{E'_b t_p^2}{2(W_b - k_r q)^3 C_f} e_{ba} \quad (8-55)$$

iv) Axial bending stresses caused by every mountain all movement

$$\sigma_{mbd} = \frac{5E'_b t_p}{(W_b - k_r q)^2 C_d} e_{ba} \quad (8-56)$$

P_p : Driving pressure (MPa)

E'_b : Length elasticity coefficient at normal temperature of bellows material (N/mm^2)

W_b : Height of mountain of bellows (mm)

q : Pitch of mountain of bellows (mm)

n_b : Number of layers of bellows

t_p : Calculation thickness of one bellows layer (mm).

k_r : Modified coefficient of bellows with reinforced ring

C_p : Modified coefficient of bend stress calculation by pressure

C_f : Modified coefficient of membrane stress calculation by movement of bellows

C_d : Modified coefficient of bend stress calculation by movement of bellows

e_{ba} : Amount of bellows of every mountain all movements (mm)

2-Total stress range calculation

Maximum axial range of stress is calculated as follows:

$$S_{am} = 0.7(\sigma_{nmp} + \sigma_{mbp}) + (\sigma_{nmd} + \sigma_{mbd}) \quad (8-57)$$

S_{am} : Maximum axial range of stress (N/mm²)

- Maximum axial stress in the bellows, caused by the displacement of the pipe supports, must be less than the allowable stress related to 500 cycles.
- To optimize the seismic performance of the piping system, it is necessary to use a proper type of expansion joints at a proper location.

8-5-3-8- Seismic Performance Evaluation of Towers/Tanks Nozzles

The method of calculating the stress of towers/tanks nozzles using the thin shell theory is explained below:

1-Thin shell stress

The stress in direction i is calculated through Equation (8-58).

$$\sigma_i = K_N \frac{N_i}{t} \pm K_b \frac{6M_{ii}}{t^2} \quad (8-58)$$

t_w : Thickness of thin wall shell (mm)

N_i : Membrane load in direction i for each unit length (N/mm)

M_{ii} : Bending moment in direction i per unit length (N.mm/mm)

K_N : Stress concentration factor, assumed 1 for membrane force

K_b : Stress concentration factor, assumed 1 for bending moment

2-Stress intensity calculation

Stress intensity is calculated through Equation (8-59).

$$S_I = M_{ax} \left(\frac{\sigma_x + \sigma_\phi \pm \sqrt{(\sigma_x - \sigma_\phi)^2 + 4\tau^2}}{2} \times \sqrt{(\sigma_x - \sigma_\phi)^2 + 4\tau^2} \right) \quad (8-59)$$

σ_x : Radius stress

σ_ϕ : Axial stress

τ : Circumferential stress

3-Spherical shell

Dimensionless geometrical parameter is used in this method.

Shell parameter (U) is a ratio of the outer diameter or the nozzle to the square of the product of shell radius multiplied by its thickness.

In hollow nozzles:

Parameter γ is the ratio of the nozzle radius to its thickness.

Parameter ρ is the ratio of the nozzle thickness to the shell thickness.

The following stresses are calculated using the above parameters:

- 1) Membrane stress and bending stress along the radial and tangential directions, caused by the radial loading

2) Membrane stress and bending stress along the radial and tangential directions, caused by the bending moment

3) Shear stress caused by the shearing force

4) Shear stress caused by the torsion moment

Maximum shear stress on the two sides of the shell around the nozzle-body connection is calculated using the above stresses.

When a plate has a supporting plate, thickness of the supporting plate must be added to that of the main plate.

4-Cylindrical shell

Shell parameter γ is the ratio of the shell thickness to the average shell radius.

When there are equipment attached:

β for the circle shaped equipment; it is the ratio of the average shell radius to the radius of equipment connection.

β_1 for the rectangle shaped equipment; it is the ratio of the longer rib of the rectangle to the average radius of the shell.

β_2 is the ratio of the shorter rib of the rectangle to the average radius of the shell

Stress intensity is calculated using graphs and dimensionless parameters, based on maximum internal and external shear stresses generated around the nozzle joint, which are calculated using longitudinal and circumferential membrane stress and bending stress, and the shear stress caused by the torsion moment and shear stress generated by the shearing force.

When there are stiffener plates, the nozzle joint are evaluated based on the thickness of the container and the stiffener plate.

The curved section of the stiffener plate is evaluated using only thickness of the container.

- In towers/tanks nozzles the stress related to the horizontal and vertical seismic forces and movements of the piping supports must be calculated.
- Details of the evaluation method are shown in Appendix 3-10.

8-5-3-9- Seismic performance evaluation of piping support structure

The seismic performance evaluation of the piping support structure (piping supporting assembly and support) is performed by confirming the calculation stress etc. caused in the important material for seismic is below the allowable stresses for the seismic design at the earthquake.

- Seismic performance of the piping support structure is evaluated through equipment evaluation methods.
- The method of evaluating seismic performance of the supports is shown in Appendix 3-11.

8-5-4- Ductility design method

When considering level-2 risk conditions, the seismic design is performed in ductility method.

The effects of the ground movements are also evaluated through displacement response method.

- Framework of the ductility design method for piping system is shown in Appendix 3-12.
- When the ground movements do not affect the piping there's no need to evaluate the seismic performance.
- Ductility in considerable deformations of the piping system depends extensively on the curves.
- Curved pipe evaluation is shown in the appendix 3-13.

8-5-4-1-1- Piping Support Structure

Seismic coefficient and displacement response of the piping support is calculated through the supporting structure response analysis.

The supporting structure is replaced by a suitable vibration system model. Acceleration response and displacement response at the support point is calculated through modified equivalent static method, spectra analysis method, or time history analysis method.

Support point displacement response analysis in modified equivalent static method is shown in Appendix 3-14-1.

8-5-4-1-2- Piping system

Acceleration and displacement of the piping system support is calculated through analysis of the supporting structure response.

Analysis of the piping system is performed using the analytical model that concerns the nonlinear behavior of the inelastic deformation.

1-Piping element

In the piping elements such as straight pipes and tees, it may be considered a linear beam element.

In the curved pipe, consider a nonlinear load and the strain relation.

2-Damping constant

The effect of the energy absorption by the plastic deformation of the curved pipe and the pipe support and the piping supports may be replaced by the damping constant that decreases appropriately.

The outline of the equivalent linear analysis and the detailed analysis, and also the response magnification factor are described in Appendix 3-14-2.

8-5-4-1-3- Failure mode

As for the piping system, the earthquake performance evaluation of the failure mode of the following items is performed for the inertial force and the response displacement.

- 1- Plastic deformation of curved pipe
- 2- Crack in bifurcation area
- 3- Crack of piping in piping support
- 4- Ratcheting
- 5- Failure of nozzle of seismic design facilities etc.
- 6- Failure of expansion joint
- 7- Leakage of high pressure gas from flange joint
- 8- Failure of pipe support

1- Plastic deformation of curved pipe

Due to the considerable ductility of the curved pipe (elbow) in the piping system, the plastic deformation is accelerated.

2-Crack in bifurcation area

The repetition of the seismic force in the discontinuity part of shape where the stress of the part concentrates, especially, fatigue crack by relative displacement of support is expected as a failure mode.

3-Crack of piping in piping support

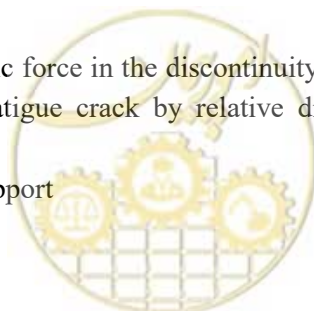

The fatigue fracture by the repetition of the seismic force in the discontinuity part of shape where the local stress concentrates is expected as a failure mode as well as the bifurcation area.

4-Ratcheting

Under a constant stress by the usual load such as the internal pressure and the dead weight, etc. the plastic strain accumulates if the repeated load of the seismic force applies and the fluctuating stress by the repeated load is caused in excess.

5- Failure of nozzle of seismic design facilities etc.

Confirm excessive reaction does not act from the piping system because the fatigue crack by the repetition of the seismic force in the discontinuity part of shape where the local stress concentrates is assumed as a failure mode as well as the bifurcation area. The nozzle is treated as a fixed part for the piping system.

6-Failure of expansion joint

The fatigue crack of the bellow that composes the expansion joint by an excessive deformation by the seismic force is assumed as a failure mode. It is necessary to confirm strength enough might not damage the tie rod (stay for cage bolt and nut) and the stay for cage board and pins, etc. to the seismic force is possessed.

On the other hand, though it is designed so that the movement of two or more bellows may become even with the adjust ring, it is necessary to confirm the structure for the bellow to be protected and to absorb the deformation by the piping at the case to have exceeded the limit of the movement. In addition, it should be a structure restrained to axial expansion and shrinking in the expansion joint with a tie rod so that movement should not become unstable.

7-Leakage of high pressure gas from flange joint

The loss of the seal function according to the decrease of the gasket bearing according to an excessive tensile force or bending moment in the seismic force and it is assumed.

8-Failure of pipe support

The loss of the support function by the plastic deformation is assumed. About the valve, it is assumed that safety is secured and the evaluation can be omitted in the ductility design method because stress is suppressed enough to a low stress in the allowable stress design method.

8-5-4-1-4- Seismic assessment of piping

The allowable ultimate plastic deformation caused by the inertial force and the response displacement of the design seismic motion is calculated using Table (8-5).

Table 8-5: Allowable ultimate plastic deformation to inertial force and response displacement

| Load | Allowable ultimate plastic deformation |
|--|---|
| Internal pressure, Dead weigh and longitudinal stress by seismic inertia force | Limitation of internal pressure ratchet |
| Range of repeated stress | Plastic strain half amplitude 2% |

In this case, the evaluation may be replaced by the following (1) or (2).

1- Evaluation of failure mode of curved pipe

It is confirmed that the distortion angle of the curved pipe does not exceed the allowable angle. Here, the allowable angle of the curved pipe θ is a distortion angle of the curved pipe corresponds to the maximum equivalent plastic strain half amplitude 2%.

2- Failure mode evaluation of branch pipes and straight pipes

An apparent stress is calculated and it is confirmed that it is below the allowable stress for the seismic design by the Table 8-6.

Table 8-6: Simple seismic performance evaluation by linear model to inertial force and response displacement

| Load | Allowable stress for seismic design | Remarks |
|--|-------------------------------------|--|
| Longitudinal stress | 2S | S: Described in 4-1-3 |
| Range of repeated stress at earthquake | 4S _y | S _y : Yield strength in design temperature of material or 0.2% proof strength |

The evaluation of failure mode of curved pipe, the evaluation of failure modes such as branchpipes and straight pipes, and the details for Ratcheting is shown in Appendix 3-14-3.

8-5-4-1-5- Seismic assessment of flange joint

The leakage evaluation is performed by the following equation, when axial direction tensile force F and bending moment M that acts on the flange joint.

$$mP_p + \alpha_1 P_e \leq \sigma_a \quad 8-60$$

P_p: Internal pressure (MPa)

α₁: Leakage impact correction factor to equivalent internal pressure

P_e: Equivalent internal pressure by axial tensile force F and bending moment M in the seismic force (N/mm²)

σ_a: Gasket bearing (unit N/mm²) by initial tightening force of bolt. However, in case no manage of the bolting, the initial tightening stress per one of the bolts is either smaller value of yield stress or 1500/√d of the bolt. Here, d is assumed to be a nominal diameter of the bolt.

A detailed studying procedure and the necessary gasket bearing of the flange joint are shown in Appendix 3-14-4.

8-5-4-1-6- Seismic assessment of expansion joint

The relative displacement at both ends of the expansion joint must be below the relative displacement allowed to the number of repetitions of 50 times by an expansion joint concerned.

In this case, it can be separately evaluated as the evaluation concerning the ground movement. For the direction where the relative displacement cannot be expected, the enough strength for the reaction calculated from the response calculation should be possessed.

Details of the evaluation procedure etc. of the expansion joint are shown in Appendix 3-14-5.

8-5-4-1-7- Seismic assessment of towers and tanks nozzle

The bending moment, the torsional moment, and the axial tension that acts on the nozzle must be below the value allowed by the nozzle.

Details of the evaluation procedure etc. of the towers and tanks nozzle are shown in Appendix 3-14-6.

8-5-4-1-8- Seismic assessment of pipe support

The evaluation of the pipe support concerning the inertial force and the response displacement is

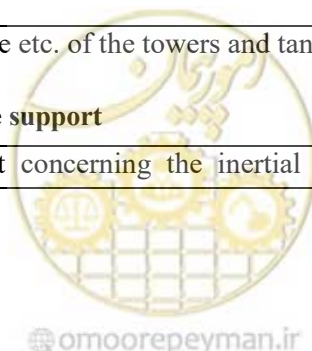

performed to the pipe support reaction calculated from the response calculation about the failure mode from the following (1) to (4).

- 1-Plastic deformation of pipe support
- 2-Crack of pipe support
- 3-Displacement limit of pipe support
- 4-Buckling limit of pipe support

The earthquake performance assessment of the pipe support is shown in Appendix 3-14-7.

8-5-4-2- Seismic Design Evaluation under Effects of Permanent Ground Deformation(geotechnical risks)

8-5-4-2-1- Piping System Design

For the piping system set up on the ground that might flow by the liquefaction, it is necessary to prevent the influence from the movement of foundation by ground movement using a common foundation. However, it is not this case if the air tightness of the high pressure gas from pipe is confirmed with the flexibility of the piping.

This is a principle that the structure must be designed to use a common foundation instead of using various foundations for piping support, in order to prevent excessive relative displacement of the piping.

8-5-4-2-2- Movement of the foundation due to the ground movement

The seismic performance evaluation of the foundation to the ground movement is performed to the maximum relative displacement between the foundations related to the foundation movements followings.

- 1-Subsidence of foundation according to liquefaction of ground and flow
- 2-Differential settlement of foundation according to liquefaction of ground and flow
- 3-Lateral displacement of foundation according to liquefaction-induced flow of ground

The amount of displacement and relative displacement between the foundations due to the ground movement is described in Appendix 3-16.

8-5-4-2-3- Response analysis method

The seismic performance evaluation to the ground movement is performed by either energy method, equivalent linear analysis method or nonlinear response analysis method or combination of them. In this case, though the curved pipe is assumed to consider a nonlinear load - strain relation, the other type of pipe can be the linear element. However, the curved pipe may calculate the linear response by using the flexibility coefficient appropriately corrected at the plastic deformation.

The flexibility coefficient of the curved pipe in the analysis of piping for the foundation movement and the analysis procedure using the flexibility coefficient are shown in Appendix 3-17.

8-5-4-2-4- Failure mode

The earthquake performance evaluation of the failure mode from the following (1) to (8) is performed for the ground movement due to the liquefaction.

- 1-Plastic deformation of curved pipe
- 2-Crack in bifurcation area
- 3-Crack of piping in piping support
- 4-Ratcheting



- 5-Failure of nozzle of seismic design facilities etc.
- 6-Failure of expansion joint
- 7-Leakage of high pressure gas from flange joint
- 8-Failure of pipe support

The allowable ultimate plastic deformation ratio is 5% for the enduring ground movements, and 2% for the inertial force.

8-5-4-2-5- Seismic assessment of piping

By calculating a pressure of fluid, an operating weight, a longitudinal stress by the seismic force, and the range of the repeated stress by the seismic force in consideration of the combination of the load of piping and the direction of the earthquake, the response plastic ratio shall be within the allowable plastic deformation ratio. In this case, it may be changed into the evaluation related to the failure mode of the curved pipe or the evaluation related to the failure mode of the branch pipes and straight pipes.

The allowable ultimate plastic deformation ratio is assumed 5% for the ground movement. In this case, it may be replaced with the evaluation by following (1) or (2).

1-Evaluation of failure mode of curved pipe

The distortion angle θ_a of the curved pipe shall not exceed the allowable angle defined in ductility factor evaluation.

Here, the allowable angle θ_a of the curved pipe is assumed to be a distortion angle of a curved pipe that corresponds to the maximum equivalent plastic strain 5%.

2-Evaluation of failure mode of branch, straight or other pipe

In the seismic performance evaluation of the branch, straight or other pipes, the calculated apparent stress should be equal to or less than the allowable stress $4S_y$ for the seismic design defined in ductility factor evaluation.

Details of the allowable angle of the curved pipe are shown in Appendix 3-18.

8-5-4-2-6- Seismic assessment of flange joint

The leakage evaluation about the flange joint is performed for the piping direction force and the bending moment calculated from the acceleration response analysis and the piping displacement response analysis of the piping.

When the tensile force F and bending moment M acts on the flange joint, the leakage evaluation is performed according to Appendix 3-19

8-5-4-2-7- Seismic assessment of expansion joint

The relative displacement at both ends of the expansion joint shall be below the relative displacement allowed to the number of repetitions of ten times to an expansion joint. The evaluation of the ground movement can be independent of evaluating inertial force and response displacement.

When the relative movement cannot be expected for the expansion joint, the joint must be strong enough against the calculated response.

Details of the estimation procedure etc. are shown in Appendix 3-20.

8-5-4-2-8- Seismic assessment of towers and tanks nozzle

The bending moment, the tensional moment, and the axial tension that act on the nozzle must be below

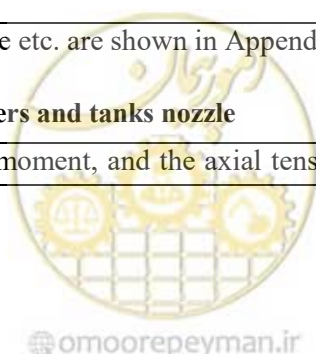

the allowable values.

Details of evaluation procedure related to the ground movement of the towers and tanks nozzle are shown in Appendix 3-21.

8-5-4-2-9- Seismic evaluation of pipe support

Seismic evaluation of pipe support is performed for the calculated responses related to failure modes 1-4.

- 1-Plastic deformation of pipe support
- 2-Displacement limit of pipe support
- 3-Release load of release support
- 4- Buckling limit of pipe support

The seismic performance assessment of the support of a ground movement is shown in Appendix 3-22.



Chapter 9

Seismic design and safety control of electrical posts



9-1- Target Equipment

Target equipment in this chapter are:

- 1-Transformers
- 2-Insulator
- 3-Bushing
- 4-Cable
- 5-Other equipment

- Posts usually include one or more transformers, switches, and control and safety equipment.
- In bigger posts, circuit breakers are used to prevent short circuit or overload, which are likely to happen in the network.
- In smaller posts automatic stoppers or fuses are used to protect the extended circuits.
- A post may include lines terminal structures, high/low voltage switches, lightning rods, control devices, and current measuring devices.
- Other equipment, such as current adjusting capacitors and voltage adjusting devices may be included in a post as well.

9-2- Damage Modes

1-Transformer

- Damage modes of a transformer include slipping along the rail, overturning, or falling off the rail.
- The most important damage modes of bushings and radiator are leakage of the oils from the ceramic component, gasket extruding and ceramic failure.

These failures are concentrated in gasket-body connection.

2-Ceramic Equipment

The most important damage mode of the ceramic equipment is the ceramic column failure, caused by excessive tensile force.

Another important damage mode is the instability of the supporting structure or permanent deformation.

3-Bus

The dominant damage mode of a bus is the ceramic failure.

9-3- Performance based seismic design method

9-3-1- Post equipment seismic design

- 1-Due to the high rigidity, high frequency, and high strength of the materials, the main body of the transformer, current transformer, and similar structures is designed through equivalent static method.
- 2-Dynamic method is used for designing insulation and bushing equipment. After controlling insulating equipment of the bus, the dynamic method can be generalized to the aluminum bus as well.
- 3-In static and dynamic analysis method, the design must be performed through allowable stress analysis method.

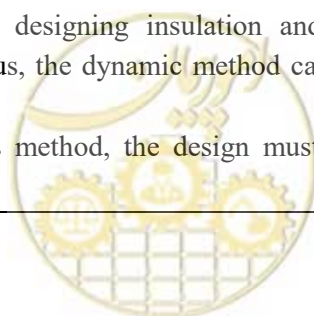

9-3-2- Static Method of Seismic Design

- 1-In equivalent static method, the seismic coefficient must be determined based on the significance of the post equipment.
- 2-The seismic coefficient must comply with the level defined in this guide.
- 3-The seismic coefficient of the equivalent static method is taken from the seismic design guide, and seismic analysis of Iran's critical infrastructures.

1-Transformer main body

Natural frequency of the transformer main body is usually 15Hz or more, and therefore amplification effect of the earthquake is not likely to happen. By the way, pipes connected to the main body must be checked.

2-Power supply unit at the station

Most of these facilities are of natural frequency of 7Hz or more, while their damping factor is 10% and above. They are mostly installed in the 1st floor or lower floor. Response magnification factor of the equipment with damping constant of 10% and above, and natural frequency of 7Hz or more, is considered maximum 1.6. Therefore the design seismic force is calculated $0.5 (0.3 \times 1.6)$. When the equipment is installed in the 2nd or 3rd floors, magnification of the building must be taken into consideration as well. Since the magnification factor at 2nd or 3rd floor of a building is around 2, the design equivalent seismic acceleration is calculated $1.0 (0.5 \times 2)$.

For upper floors, the magnification factor of the building must be calculated for the equipment.

3-Electrical panel

Electrical panels are of various structure types. Studying the results of seismic tests on the electrical panels, defines the response magnification factor of the electrical panels as 2.5 or less. The static horizontal acceleration of $1.5 (0.3 \times 2.5 \times 2.0)$ is taken as the standard value in design of the electrical panels set up in the 3rd floor or lower floors. For upper floors, response magnification factor must be calculated for the equipment. Adequacy of the internal strength of the electrical panel against the incoming acceleration must be evaluated as well.

Specific attention must be paid to the fall of components such as relays.

4-Air compressor

Since the natural frequency of the air compressor is more than 15Hz, and its body is rigid, its horizontal acceleration is considered like that of the transformer body.

9-3-3- Dynamic Analysis Method

- 1-Considering the potential of vibration amplification in bushing equipment, dynamic method is used to analyze their behavior.
- 2-Both vertical and horizontal factors of the earthquake must be taken into consideration in dynamic analysis.
- 3-Damping vibration with three sine waves, or the natural period of the equipment, is taken as the input of the seismic analysis of the bushing equipment.

1-Design seismic force at the ground level

1-1-Horizontal acceleration

In triple sine wave method the horizontal acceleration is assumed 0.3 at the ground level.

1-2-Vertical acceleration

Vertical acceleration is usually half of the horizontal acceleration. Since the effect of the vertical acceleration on most of the facilities is structurally insignificant, in many cases there is no need

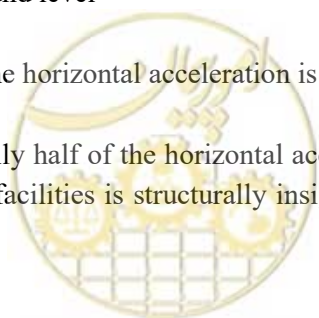

for considering this acceleration. The vertical acceleration is taken into consideration only for the especial structures (wall bushing and similar structures), which receive the effects of the vertical wave. Shape of the wave and time of the maximum occurrence are different in horizontal and vertical acceleration, and need to be checked separately.

1-3-Input wave

- Since the dominant frequency of most of the insulating, bushing, and aluminum bus equipment ranges from 0.5 to 1Hz, amplification of their natural frequency is likely to happen. Therefore, the sine wave with the natural frequency of the system shall be taken as the most unfavorable input state.
- A method of amplification is considering n cycle of sine wave with amplification frequency as the input equal to a real earthquake wave.

The equipment response to the earthquake generated by two sine waves is bigger than the equipment response to the real earthquake wave. Therefore, the design wave consists of two sine waves with horizontal acceleration of 0.3. This input wave is conservative to some extent.

2-Design seismic force

2-1-For two sine waves

- Insulation equipment: two sine amplification waves with maximum input acceleration of 0.3 at the lower end of the support
- Aluminum pipe bus: two sine amplification waves with maximum acceleration of 0.3 at the lower end of the frame
- Transformer bushing: two sine amplification waves with maximum input acceleration of 0.3 at the lower end of the metal pier.

For the insulation equipment and aluminum bus, the magnification factor is 1.2 (with foundation), and for transformer bushing, with foundation and main body of transformer, the magnification factor is 2. Also uncertainty factor 1.1 is taken into consideration for determining the effect of the vertical acceleration and attached accessories.

2-2-For three waves

- Insulation equipment: three sine amplification waves with maximum input acceleration of 0.3 at the lower end of the support.
- Transformer bushing: three sine amplification waves with maximum input acceleration of 0.5 at the lower end of the metal pier
- Aluminum pipe bus: three sine amplification waves with maximum input acceleration of 0.3 at the lower end of the frame

For insulation equipment whose magnification factor (with foundation) exceeds 1.2, it is necessary to use interactive analysis.

For aluminum bus, for f_1/f_0 ratio (ratio of the natural frequency of the equipment (f_1) to the natural frequency of the foundation and the ground (f_0)) of 0.3 or less, the magnification ratio considering the foundation can be assumed 1.2.

For comparing two-wave and three-wave states, conversion rate of 1.3 is used for damping of 5%.



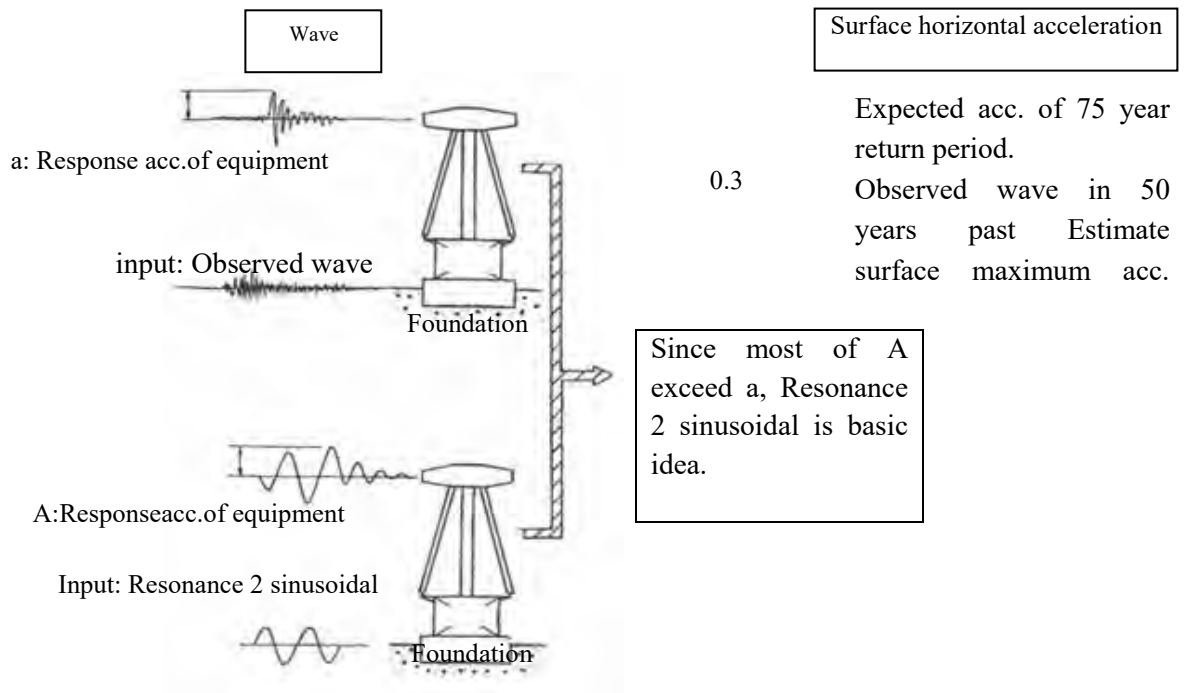

Figure 9-1 (a): Design input seismic force

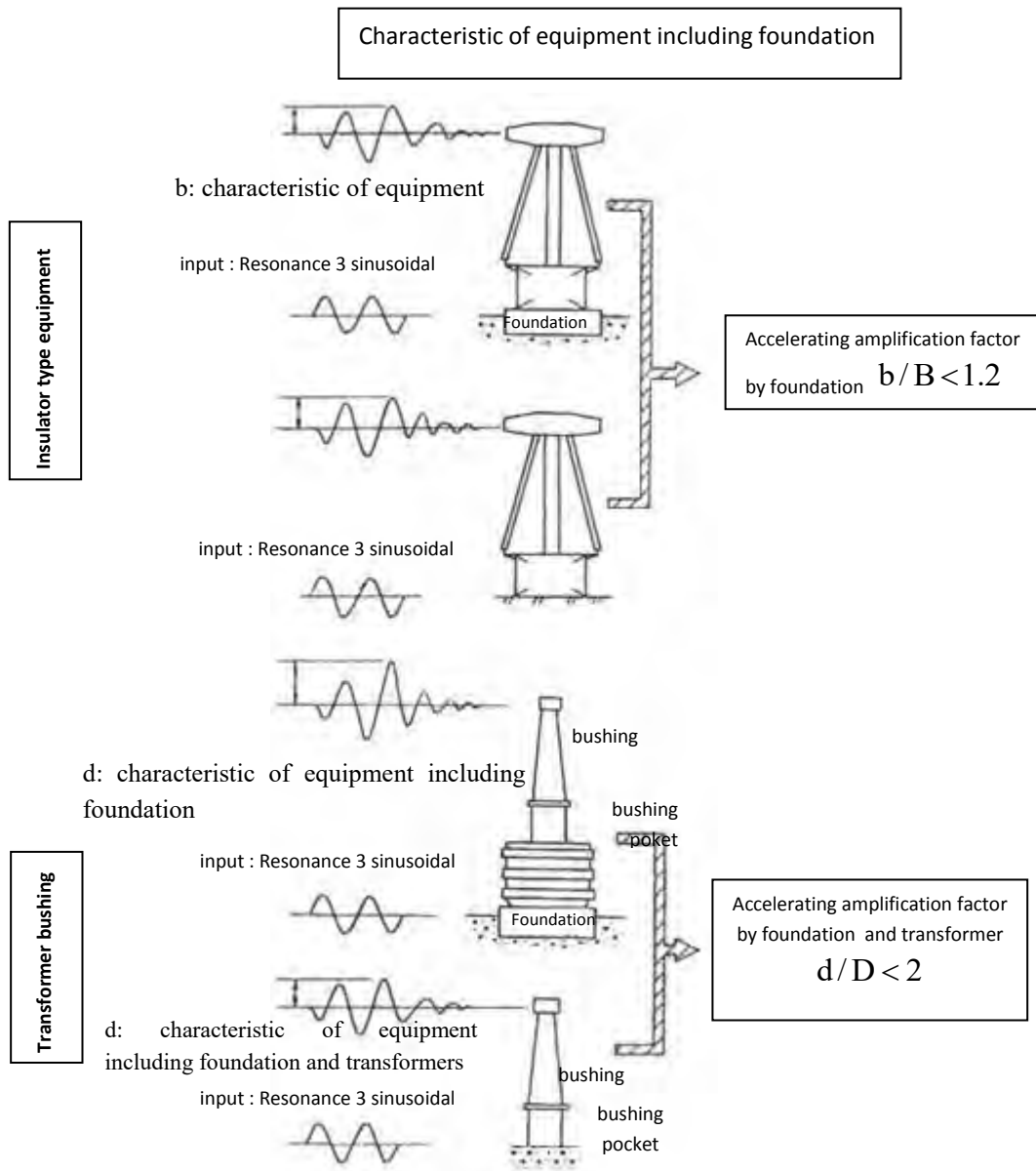

Figure 9-1 (b): Design input seismic force



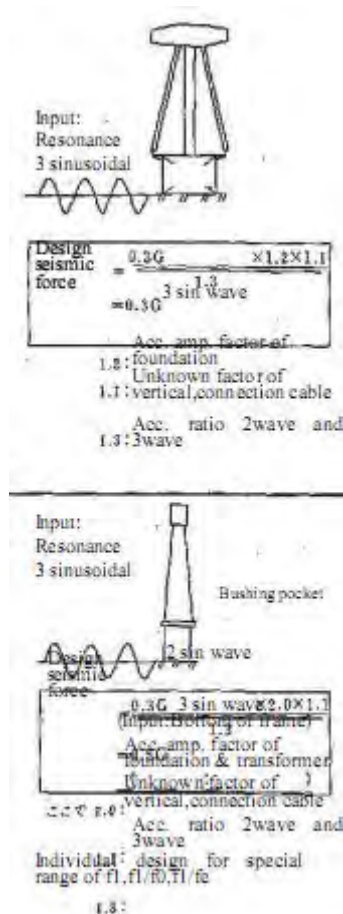

Figure 9-1 (c): Design input seismic force

3-Design condition of transformer bushing

The design seismic force of the transformer bushing was set as described in (2). The response property of the transformer bushing is shown in Fig. 9-1. Big difference with the insulator type equipment is that considering the heavy weight of the main body, which is located between the foundation and the bushing system (including the metal pier), the transformer bushing response is controlled by the anti-vibration features of the system (ground, foundation, and the main body). Therefore, the bushing, being of low weight, can hardly influence the transformer system response. By the response analysis of two-mass model of the bushing system the following response properties are clarified:

- 3-1-The bushings response to the 2 sine amplification waves at the ground level is usually more intense than their response to the natural earthquake wave, when we disregard the natural frequency of the bushing system.
- 3-2-If the response of the upper end of the transformer is converted to amplified sine waves, number of the waves is usually less than 2, and generation of more than 3 waves has been never experienced.
- 3-3-Although the bushing response to three sine amplification waves with maximum acceleration of 0.5 at the lower end of the metal pier of bushing, exceeds the bushing response to the real earthquake wave with acceleration of 0.3 at the ground level in most cases, in the range where

f_1/f_0 ratio is around 1, the response to the real earthquake wave with maximum acceleration of 0.3 is sometime bigger than the response to the sine wave. In 400KV and 132KV bushings, the bushing response to three amplification waves with maximum acceleration of 0.5 at the lower part of the metal pier is smaller than the bushing response to the real earthquake wave with maximum acceleration of 0.3.

3-4-In 230KV bushing, when f_1/f_0 ration is 0.8-1.2, and f_1/f_e is 0.5-1.5, there is an amplification state, in which the response to the real incoming seismic wave with maximum acceleration of 0.3 at the ground level is smaller than the response to three sine waves with maximum acceleration of 0.5 at the lower part of the bushing pier.

When V_S is 2700 m/s or more (25 times of the standard N value), excluding the equipment with large foundation, f_0 is around 10Hz or more.

9-3-4- Bushing Equipment Seismic Design

1-For the landscape equipment with ceramic cover

If the magnification ratio is $\frac{1}{2}$ or less, the standard design force mentioned above can be used, and the whole system (ground, foundation, and equipment) shall be considered with two sine amplifying waves with maximum acceleration of 0.3 at the ground level, or the real earthquake wave.

2-For bushing with the following conditions:

400KV bushing, when $N \leq 10$ without shoring

$$0.8 < f_1 / f_0 < 1.2 \quad (9-1)$$

$$0.5 < f_1 / f_e < 1.5 \quad (9-2)$$

230KV Bushing

$$6\text{Hz} < f_1 < 8\text{Hz} \quad (9-3)$$

$$N < 25 \quad (9-4)$$

$$0.8 < f_1 / f_0 < 1.2 \quad (9-5)$$

$$0.5 < f_1 / f_e < 1.5 \quad (9-6)$$

f_1 : Natural frequency of the bushing system

f_0 : Natural frequency of the ground, foundation, and transformer main frame

The whole system (ground, foundation, transformer body, and bushing system) shall be considered with two sine amplification waves with maximum acceleration of 0.3 at the ground level, or with the real earthquake wave.

3-For the aluminum bus with f_1/f_0 ratio of 0.3 or more, the whole system (ground, foundation, aluminum bus system) must be considered with two sine amplification waves with maximum acceleration of 0.3 at the ground level, or with the real earthquake wave.

4-The internal equipment set up in the 2nd floor or upper floors require especial design. Analysis of the post building in such cases must be performed using the real seismic wave, and input response of each floor is taken as the input of the system in the same floor.

9-3-5- Other Equipment

1-Power supply unit, electrical panels, and air compressors

Power cable, control cable, and pressured pipe do not require seismic design.

In design phase and construction period excessive attention must be paid to the serious risk of the equipment failure. Static methods can be used to control this issue.

2-The power supply unit must be designed for static horizontal acceleration of 0.5 (1st or lower floors).
 The switch boards must be designed for static horizontal acceleration of 1.5 (3rd or lower floors).
 The air compressor must be designed for static horizontal acceleration of 0.5 (1st or lower floor).

9-3-6- Equipment Seismic Design Characteristics

In the seismic design of the equipment, the seismic force at the height of the equipment is applied considering the foundation and pier effects.

1-External insulation equipment characteristics

In order to understand the behavior of the equipment, it is necessary to consider the effect of neighboring ground and foundation.

To simplify the control stages, it is necessary to apply the magnification generated by the foundation to the input vibration at the ground level for the input vibrations at the lower end of the pier.

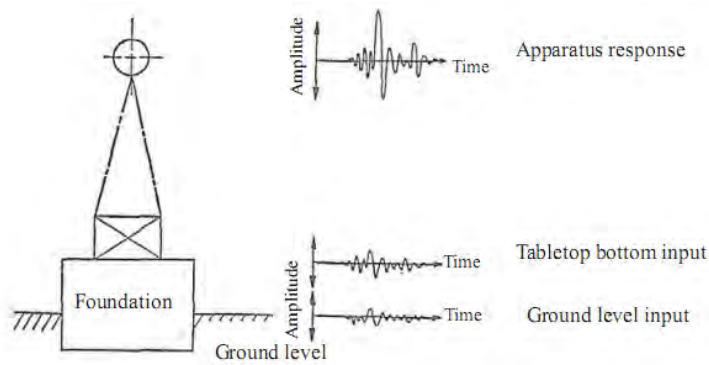

Figure 9-2: Insulation response characteristics

Magnification factor, considering the foundation as the indicator of the foundation effect magnification, is defined as follows. This is shown in Figure (9-3).

$$\text{Magnification factor considering the foundation} = \frac{\text{Equipment response when the input wave acts at the ground level (equipment response when set up in the place)}}{\text{Equipment response when the input wave acts below the lower level of equipment (equipment response during excitability test)}} = \frac{B}{b}$$

“Magnification factor considering the foundation” depends on f_1/f_0 ratio.

According to Figure (4-9), the closer f_1/f_0 gets to 1, the bigger the magnification factor would be.



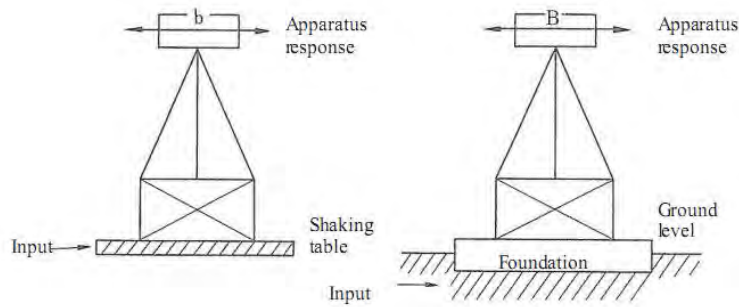

Figure 9-3: Magnification factor considering the foundation

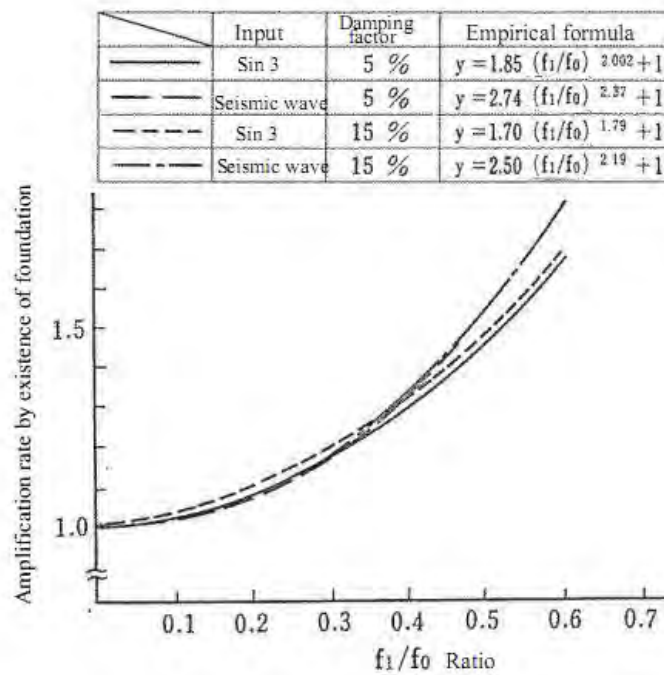

Figure 9-4: Relationship between magnification factor, foundation, and f_1/f_0 ratio

Moreover, f_0 depends on rigidity of the ground, which is calculated using the velocity of the shearing wave V_s at the ground surface layer. When V_s increases, f_0 increases as well, which results in decreasing the magnification factor.

Results of the studies on “magnification factor considering the foundation” for ground, foundation, and natural frequency of various types of insulation equipment produced by various manufacturers are shown in Figure (9-5).

For most of the insulation equipment “magnification factor considering the foundation” equals 1.2 when $V_s \geq 150$.



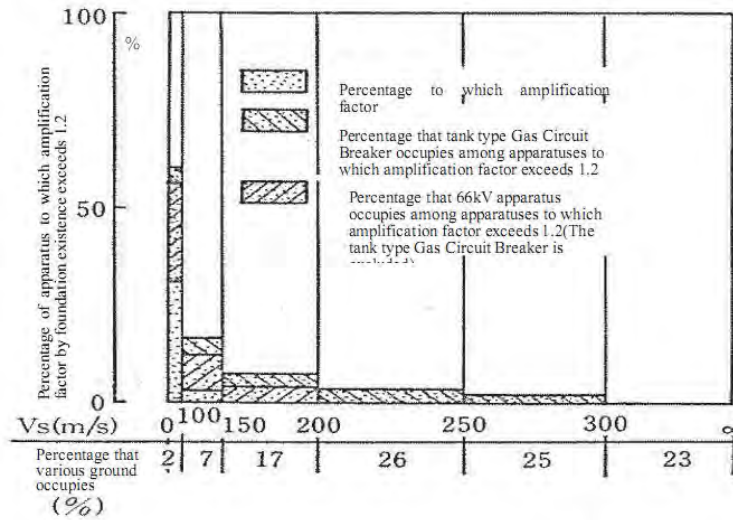

Figure 9-5: Percentage of the case where the amplification factor by existence of foundation

2-External transformer bushing seismic response characteristics

Transformer bushing shows the same behavior of the insulation equipment as shown in Figure (9-6).

In such cases the uplift phenomenon must be taken into consideration, just as the effects of the ground, foundation, main body, etc. are being concerned.

Modified input at the ground level is considered at the lower part of the bushing metal pier.

The magnification value considering effects of foundation and ground may be shown by the magnification factor (Figure 9-7) as well.

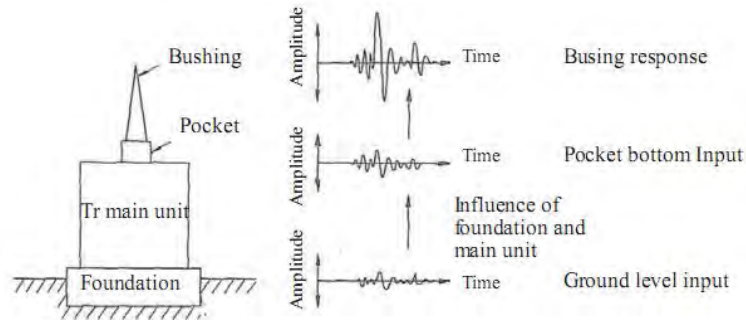

Figure 9-6: Transformer bushing response characteristics

$$\text{amplification factor considering transformer pier and body} = \frac{\text{Bushing response when the input acts on the surface (when the transformer is installed at the place)}}{\text{Bushing response when the input acts at the lower level of the pier (response during the excitability test)}} = \frac{B}{b}$$



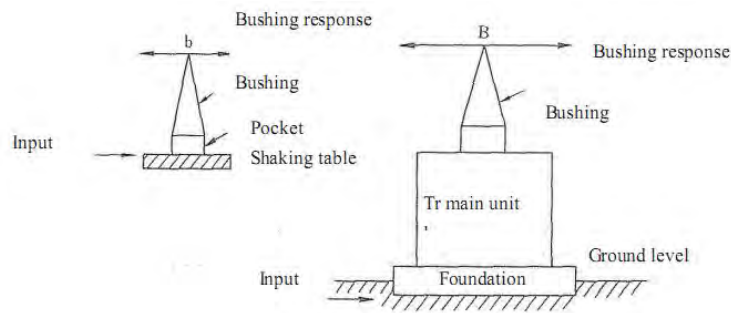

Figure 9-7: Magnification factor considering foundation and transformer main body

- 2-1-As per the insulation equipment, “magnification factor considering foundation and transformer main body” depends on f_1/f_0 ratio.
- 2-2-As shown in Figure 9-8, since f_1/f_0 is likely to get close to 1, the factor increases considerably and becomes different from that of the insulation equipment.
- 2-3-The magnification factor can reduce due to deformation of the foundation (for example when the foundation is widened).
- 2-4-Therefore, if the considerations related to increasing difference between f_1 and f_0 or selection of the foundation shape are performed appropriately, the magnification factor considering foundation and transformer body would be around 2%.

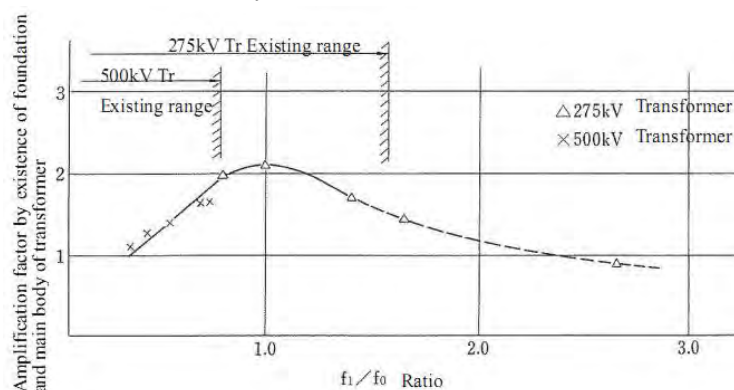

Figure 9-8: magnification factor considering foundation and transformer body

3-Internal transformer bushing and insulation equipment response characteristics

Although for internal transformer bushing and insulation equipment response, unlike the external type, only the effects of the building are assessed instead of those of the foundation, response of each building needs to be studied separately.

When the equipment is installed in the basement or 1st floor, they can be treated like the external type.

3-Aluminum bus response characteristics

The steel frame, insulation, and aluminum bus include a large number of 2-7Hz amplification points, and amplification is likely to happen in the equipment. Value of amplification considering the effects of soil and foundation for 400Kv equipment equals 1.2.

As shown in figure 9-9, these values can be used when $f_a/f_0 \leq 0.3$.

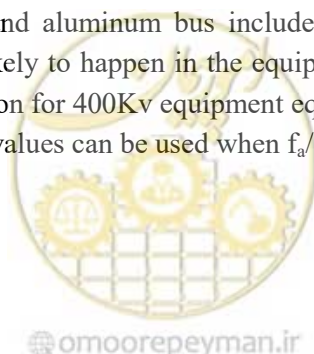

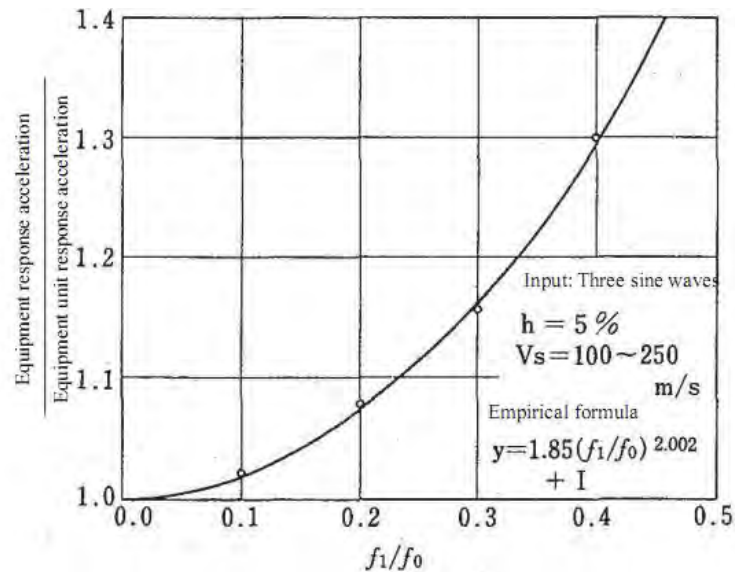

Figure 9-9: Relationship between magnification factor and f_1/f_0 ratio

9-4- Cable design procedure

- 1-Methods defined in part 10-3-2 shall be used for seismic design of the wires or aerial cables.
- 2-Seismic design of the buried cables must be based on the ground strain or the pipe displacement.

9-4-1- Failure modes of power cables

Failure modes of the buried cables under effect of wave propagation and geotechnical risks (fault crossing, liquefaction, and land slide) must be taken into consideration in design and construction.

Cables located in manholes and buildings must be checked for seismic safety.

During the earthquake, the cables buried in ducts experience a smaller vibration range compared to the ground vibration range. The sliding between duct and cable keeps the power cables within the elastic range even during very strong quakes. Therefore propagation of the seismic waves has no significant effect on the cables and does not possess an important failure mode. Geotechnical risks, or enduring ground deformations, including fault crossing, liquefaction, land slide and uneven sinking cause critical deformations in cables. The excessive stress caused by reverse movement of the faults towards the cable direction (at intersection with direct-sliding faults) or the fault compression makes Z-shaped damages to the cables (Figure 9-10), as shown in Figure (9-11). Movements of the fault along the cable direction (at intersection with direct-sliding faults) or normal faults pull out the cables resulting in tensile failure mode. In liquefaction areas, extensive deformations of the ground result in longitudinal and latitudinal deformation of the cables.

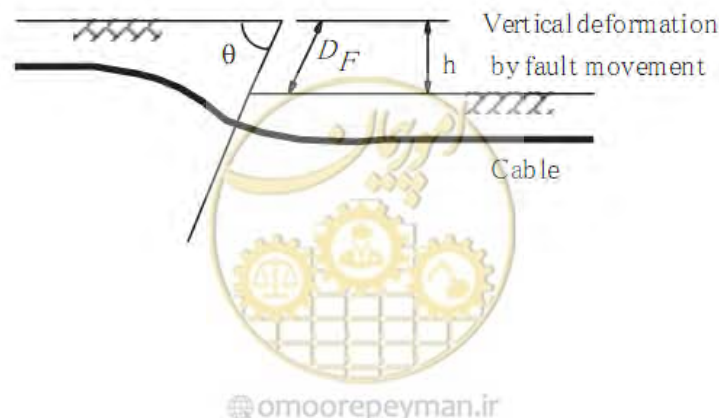

Figure 9-10: Cable deformation at intersection with compressive faults (reverse)

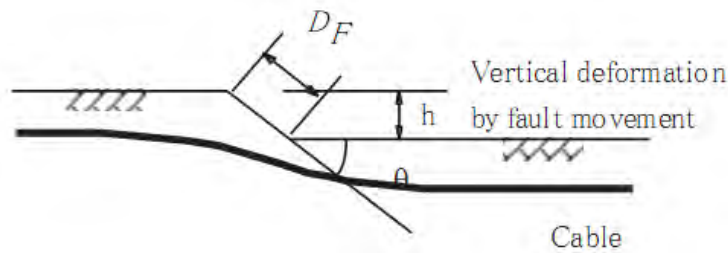

Figure 9-11: Cable deformation at intersection with normal faults

Figure 9-12 shows an example of longitudinal shear of the buried cable. Figure 9-13 shows another example, where two manholes have moved due to the ground deformation and have caused tensile failure of the cables. The earthquake results in considerable deformation of the ground and pulls out the cables. In aerial cables, usually a large catenary occurs in the longitudinal profile. Figure 9-14 shows an example of land slide and deformed cable.

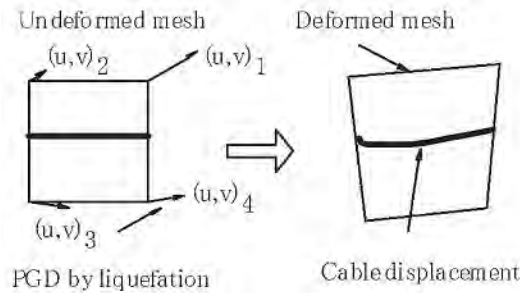

Figure 9-12: Cable deformed by liquefaction

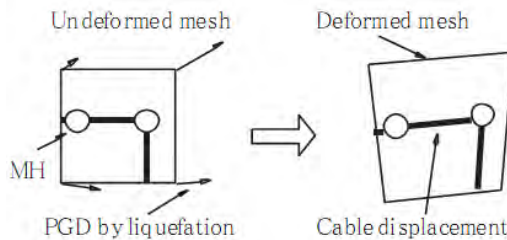

Figure 9-13: Displacement of the cable connected to a manhole due to liquefaction

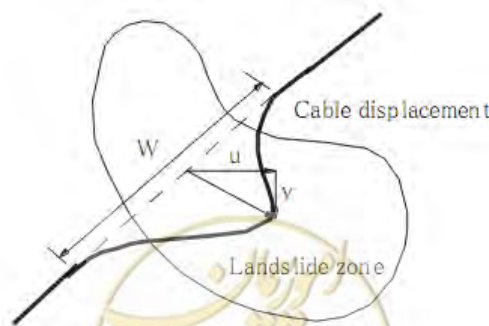

Figure 9-14: Cable displacement due to the land slide

9-4-2- Design procedure of buried cables

9-4-2-1- Ground deformation

When the bending rigidity of the cable is insignificant, the failures occur if the elongation ΔL exceeds the critical limit.

1-Cable elongation ΔL is calculated through Equation (9-7).

$$\Delta L = \int_0^{L_{ic}} \sqrt{1 + \left(\frac{df}{dx}\right)^2} dx - L_{ic} \quad (9-7)$$

$f(x)$: Profile function along the cable

L_{ic} : Initial length of the cable

The cable strain ϵ_{cable} is calculated through Equation (9-8).

$$\epsilon_{cable} = \frac{\Delta L}{L_{ic}} \quad (9-8)$$

2-Wave propagation

Strain caused by the wave propagation in the ground is bigger than the cable strain, and can be a proper criterion of determining maximum cable strain. Cable strain is almost equal to the ground strain ϵ_G and can be calculated through Equation (9-9).

$$\epsilon_{cable} \approx \epsilon_G \quad (9-9)$$

3-Fault intersection

Cable strain at intersection with faults is calculated through Equation (9-10).

$$\epsilon_F = \frac{d}{L} \quad (9-10)$$

d : Fault movement from Equation (9-11)

L : Effective length of cable from Equation (9-12)

$$d = \frac{h}{2 \sin\left(\frac{\theta}{2}\right)} \quad (9-11)$$

$$L = \sqrt{\frac{2E_2 d}{q} + \left(\frac{\sigma_1 - \sigma_o}{q}\right)^2} - \frac{\sigma_1 - \sigma_o}{q} \quad (9-12)$$

q : Sliding strength per unit of length

h, θ : As per defined in figures (9-10), (9-11), (9-15), and (9-16)

σ_1, σ_2, E_2 : Critical stresses and secondary modulus defined in figure (9-17)



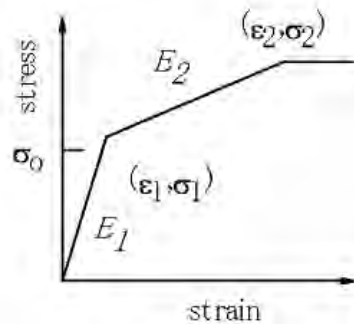

Figure 9-15: Stress curve, strain of a cable element

4-Liquefaction

Maximum cable strain in the liquefaction areas is considered equal to the axial strain of the ground. When the structure connected to the cables move, the cables undergo tensile or compression. Approximate cable strain is shown in Figure 9-18 using movements of two structures.

$$\varepsilon_{L1} = \frac{\Delta L}{L_{ic}} \quad (9-13)$$

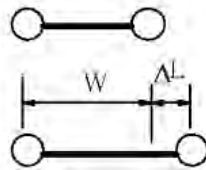

Figure 9-16: Cable elongation between two structures

5-Land slide

Cable strain caused by the land slide is calculated through Equation (9-14).

$$\varepsilon_{LS} = \frac{\Delta L}{L_{ic}} \quad (9-14)$$

9-4-2-2- Connecting to the structures

1-Duct

When the cable shows an elastic behavior in the duct, the maximum strain is calculated through Equation (9-15).

$$\varepsilon_D = \frac{D}{2EI} \left(\frac{7}{12} q_w L_{ic2}^2 + \frac{2}{3} C_1 L_{ic2} \right) \quad (9-15)$$

Here D , q_w , and L_{ic2} are cable diameter, unit weight of the cable, and effective length of the cable.

$$C_1 = \frac{q(L_{ic2}^3 - L_{ic1}^3 + 2L_{ic2}L_{ic1}^2) + \frac{12hEI}{L_{ic1}}}{2(L_{ic1}^2 + L_{ic2}^2)} \quad (9-16)$$

Here h , L_{ic1} , and EI are vertical displacement of the fault, horizontal length, and bending rigidity of the cable.

2-Manhole and building

Maximum strain is calculated through Equation (9-17).

$$\varepsilon_{MH} = \frac{\sqrt{L_{ic}^2 + h^2} - L_{ic}}{W} \quad (9-17)$$

$$L_{ic} = \frac{2\pi}{\beta}, \beta = \sqrt[4]{\frac{K}{4EI}} \quad (9-18)$$

K and EI are spring modulus between earth and cable, and bending rigidity of the cable.

1-Duct

When uneven sinking takes place on the ground, the cables buried in the duct are deformed as shown in Figure 9-15.

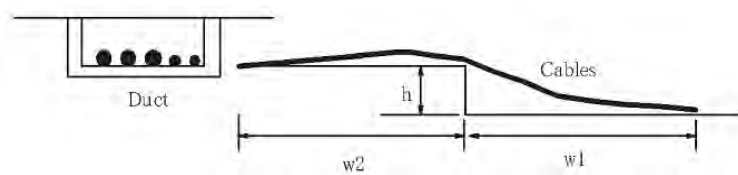

Figure 9-17: Cable deformation due to the uneven sinking of the duct

2-Manhole

As shown in Figure (9-16) the power cables are set up in a holed box, which is a component of the manhole. When the manhole uplifts or overturns due to the liquefaction, the power cables are pulled out. If the deviation angle exceeds the critical limit the cables would fail.

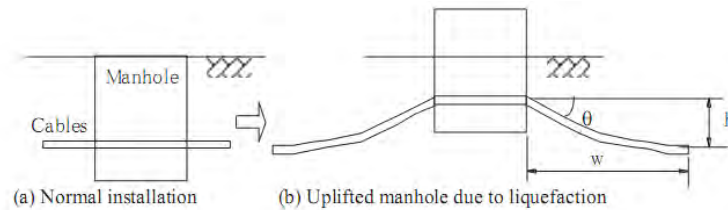

Figure 9-18: Cable displacement due to the duct uplift

3-Building

Failure modes in cables connected to the building are similar to those of the manhole.

9-5- Allowable material properties

- 1-Quantities stated in Chapter 4 of this guide must be used for material properties and allowable stress.
- 2-When required, the allowable quantities stated in the related section of National Construction Code of Iran or any other valid codes can be used.
- 3-Bushing material failure characteristics of the products of various companies are different from each other.
- 4-Generally, allowable stress is 20 N/mm² for normal bushings and 40 N/mm² for high resistance bushings.
- 5-Allowable cable characteristics are defined by the manufacturers or through standard tests.



Chapter 10

Seismic design and safety
control of transmission and
distribution lines



10-1- Target Equipment

In this chapter we discuss the seismic design of the following equipments:

- 1-Steel transmission towers
- 2-Concrete or steel utility poles
- 3-Wires and cables

The requirements of seismic design for aerial transformer connections apply to the utility pole distribution network as well.

10-2- Seismic Design

10-2-1- Transmission Tower

- 1-The towers are mostly steel and are designed through equivalent static method, considering the seismic inertial force.
- 2-They story seismic coefficient is used for mounting the equipment on the towers.
- 3-For seismic analysis of the buried foundation of the tower, the displacement analysis method shall apply.
- 4-The dynamic method is used when more details of the structure seismic behavior is required due to the exclusive geographical phenomena, site conditions, and structure type.
- 5-Wind and earthquake loads are compared in the design phase and one with more significant effects would be taken into consideration.
- 6-Towers designed for the wind force, resist the earthquake as well, regardless of the soil instability effects.
- 7-As the tower is much less rigid than its foundation, there are no differences between analytical models of the anchored towers and the real conditions (foundation, tower, and ground) in evaluation of the natural period and the vibration mode.
- 8-Separate responses of the tower and the foundation are similar to the tower-foundation response in tower-foundation-ground system.
- 9-Characteristics of the vibration perpendicular to the transmission line varies due to the vibration of components such as wires and insulations.
- 10-Vertical component of the earthquake
 - Maximum vertical acceleration at the ground level is almost half of the maximum horizontal acceleration. Maximums of the two cannot take place at the same time.
 - Effects of the vertical earthquake on the tower response can be ignored; but the effect of the vertical earthquake on the arm response cannot be disregarded.
 - In seismic design of the arm, the vertical seismic coefficient is assumed half of the horizontal coefficient.

10-2-2- Piers

- 1-In the design phase, excessive attention must be paid to the ground conditions, geography, and urban planning.
- 2-Aerial systems are exposed to the loads of wind, snow, temperature changes, and earthquake.

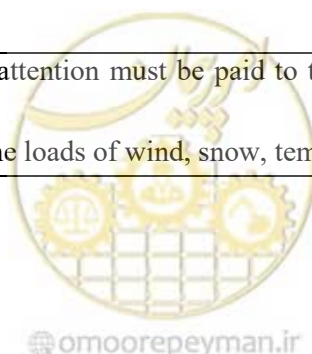

- 3-The wind load applied on the cable affects the strength of the utility pole and loading capacity of the foundation soil.
- 4-The parallel tensile force applied on the cable generates tensile force in the supporting wires connected to the utility pole.
- 5-The dead gravitational load of the utility pole, weight of the steel fixtures, weight of the cable and vertical component of the supporting wire apply all the time.
- 6-Wind force is usually greater than the earthquake force.
- 7-The force generated by the earthquake is considered as the secondary force.
- 8-Seismic loading is performed through equivalent static method.

10-2-3- Aerial Transformer

Seismic design of the aerial structures includes the following components:

- 1-Hanging wire and supporting wire
- 2-Pier
- 3-Wiring

There are three methods for connecting the transformer to the pole; direct connection, hanger connection, and plate-based connection.

The transformer must be fixed to on the pole firmly, so that the car crashes and earthquakes cannot detach it from the pier.

Safety control of the aerial transformer shall be based on the experience or in a proper method of calculation considering the magnification factor of the acceleration at the transformer height. Transformer is designed through equivalent static method.

10-3- Seismic Design Calculation

10-3-1- Towers

- 1-Determining type and size of the structure

Initial type and size of the structure is designed based on the wind load, and checked for the earthquake load.

Tower of foundation designed for the wind load shall be safe during the earthquake, provided that the soil is in good conditions.

- 2-Calculation method selection

2-1- Effects of earthquake on the tower and foundation at the ground level is assessed by the inertial force.

2-2- For buried foundations, ground displacement calculated through displacement response analysis method, is regarded as the seismic load.

2-3- When the above mentioned methods are not adequate, or there is a need for more details about the seismic behavior, dynamic method shall apply.

- 3-Safety control

Tower safety is evaluated using results of various calculation methods under various conditions and assumptions.

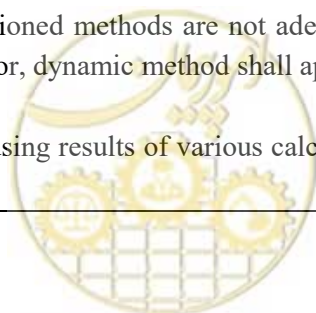

For seismic design of the towers we use curves, which are prepared using parametric studies and through response spectra analysis method, for tower system, insulation, and wiring, considering the effects of the neighboring tower, and changes of tower type and height, horizontal angle, vertical angle, and transmission line span.

To do this, in the design phase, the tower must be in range of the values shown in Table 10-1.

Table 10-1: Parametric studies range

| | |
|------------------|-----------|
| Tower Height | 100~170m |
| Horizontal Angle | 0°~ 60° |
| Vertical Angle | -30°~ 30° |
| Span Length | 300~800m |
| Number of lines | 2 |

10-3-1-1- Natural Period of Tower

Natural period of the tower is calculated through Equations (10-1) and (10-2).

$$T_0 = 1.23X^{0.29} \text{ Along the line} \quad (10-1)$$

$$T_0 = 1.14X^{0.29} \text{ perpendicular to the line} \quad (10-2)$$

T_0 : Natural period (sec)

X: Calculated through Equation (10-3) (sec)

$$X = \sqrt{\frac{(W_T + W_C)H^2}{g \cdot E \cdot I_B}} \quad (10-3)$$

W_T : Weight of the tower (t)

W_C : Effective weight of the wiring (Table 10-2) (2)

H: Height of the tower (m)

g: Gravitational acceleration (m/s^2)

E: Elasticity modulus of the tower components (t/m^2)

I_B : Bending rigidity of the tower where the moment applies (equal to the second inertial moment of the section) (m^4)

Table 10-2: Effective weight of the wiring

| Insulation type | Input earthquake direction | Effective weight (compared to the total weight) |
|-----------------|----------------------------|--|
| Hanger Type | Along the line | 0% |
| | Perpendicular to the line | 0% |
| | Vertical direction | 50% |
| Tensile Type | Along the line | 50% |
| | Perpendicular to the line | 0% |
| | Vertical direction | 50% |

To calculate weight of the tower and wiring, weights of the body, the arm, the wiring, etc. must be taken into consideration.

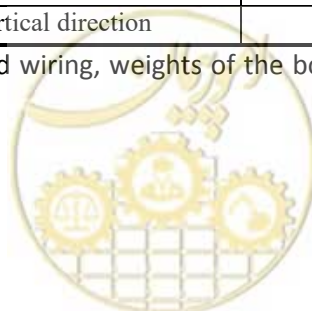

10-3-1-2- Shearing force and bending moment at various levels

1-Shearing force and bending moment of each level must be calculated through equations (10-4) and (10-9) in parallel and perpendicular direction.

$$Q_i = C_{Si} \cdot W_i \quad (10-4)$$

$$M_i = C_{Mi} \cdot W_i \cdot H_i \quad (10-5)$$

Qi: Shearing force at the height of h_{bi} from the tower foundation

Mi: Bending moment at the height h_{bi} from the tower foundation

Hi: Distance of the height h_{bi} from the center of gravity of the section above h_{bi}

(CMi)CSi: Shearing coefficient at height h_{bi} from the tower foundation (moment coefficient at the height h_{bi})

$$W_i = \sum_{j=1}^i W_j \quad (10-6)$$

Wi: Weight of the tower from height h_{bi} to the upper end (t)

$$H_i = \sum_{j=1}^i W_j (h_{bj} - h_{bi}) / W_i \quad (10-7)$$

h_{bj}: Height of the panel j from the tower foundation (m)

W_j: Weight of the panel j

In this case the shearing coefficient and the bending moment are calculated through Equations (10-8) and (10-9).

$$C_{Si} = R_S \cdot A_{Si} \cdot K_H \quad (10-8)$$

$$C_{Mi} = R_M \cdot A_{Mi} \cdot K_H \quad (10-9)$$

(RM)RS: Response characteristic coefficient related to the shearing coefficient (related to the bending moment coefficient), which is explained in the following article.

(AMi)ASi: Distribution coefficient related to the shearing coefficient (related to the bending moment coefficient) of the tower body, which will be explained later.

KH: Design horizontal seismic intensity

2-Shearing force and arm moment must be calculated in parallel direction, perpendicular direction, and vertical direction, using Equations (10-10) to (10-13).

In the parallel and perpendicular direction:

$$Q_{Ai} = A_{ASi} \cdot R_S \cdot K_H \cdot W_{Ai} \quad (10-10)$$

$$M_{Ai} = A_{AMi} \cdot R_M \cdot K_H \cdot W_{Ai} \cdot l_x \quad (10-11)$$

In the vertical direction:

$$Q_{Ai} = A_{ASi} \cdot K_V \cdot W_{Ai} \quad (10-12)$$

$$M_{Ai} = A_{AMi} \cdot K_V \cdot W_{Ai} \cdot l_x \quad (10-13)$$

Q_{Ai}: Shearing force of the arm at the height h_{bi} from the tower foundation (t); it is assumed constant along the arm.

M_{Ai}: Bending moment of the arm at the height h_{bi} from the tower foundation (t-m)

(A_{AMi})A_{ASi}: Distribution coefficient related to the shearing force coefficient at the arm level (related to the bending moment coefficient)

W_{Ai}: Weight of the arm at the height h_{bi} from the bottom of the tower

l_x: Distance from the top to the end of the arm (m)

K_V : Vertical seismic coefficient (K_{SH} is assumed 0.5)

10-3-1-3- Response characteristic coefficient related to the shearing and moment coefficient at a given level

Response characteristic coefficient R_S related to the shearing coefficient of the level, and response characteristic coefficient R_M related to the moment coefficient of the level, must be calculated through Figures (10-1)-(10-4), based on the natural period T_0 of the tower, and the ground type in terms of vibration conditions.

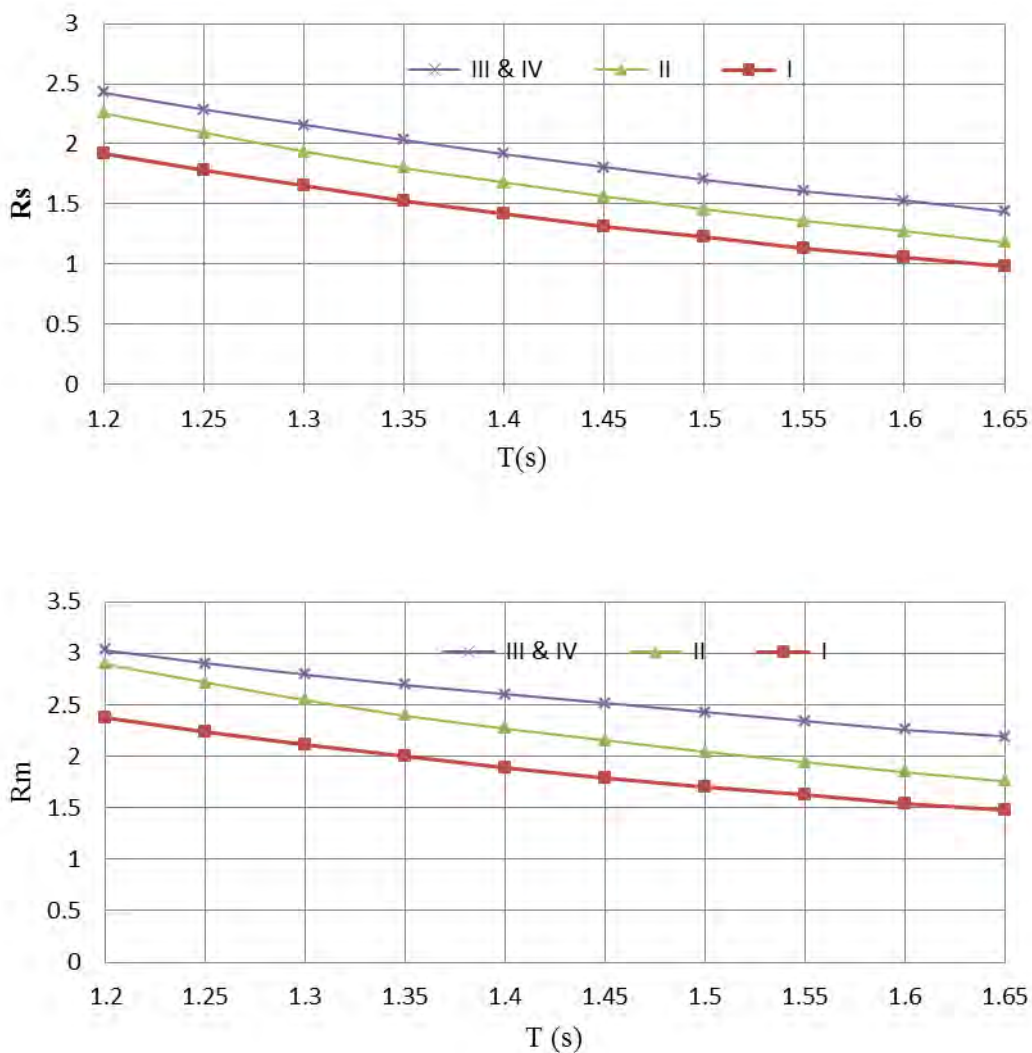
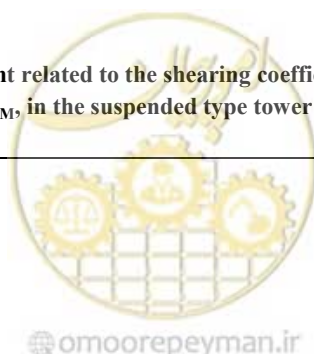

Figure 10-1: Response characteristic coefficient related to the shearing coefficient at the level and the moment coefficient at the level, R_S and R_M , in the suspended type tower (parallel direction)



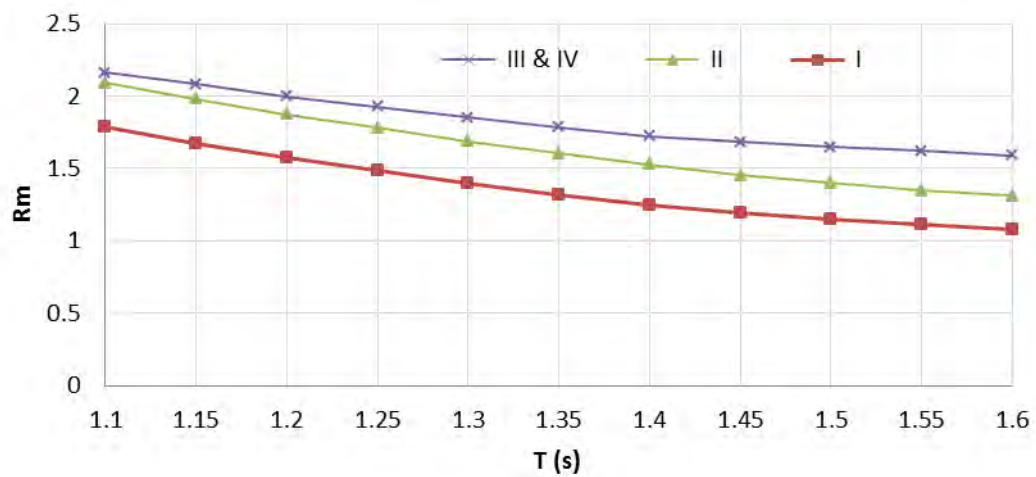
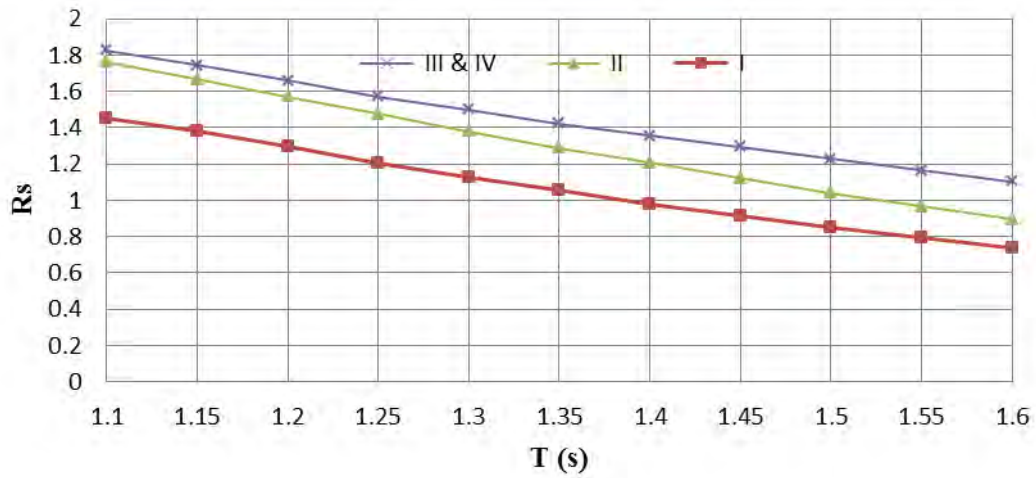
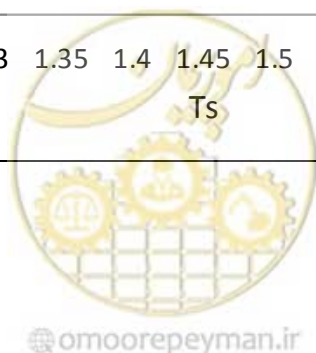
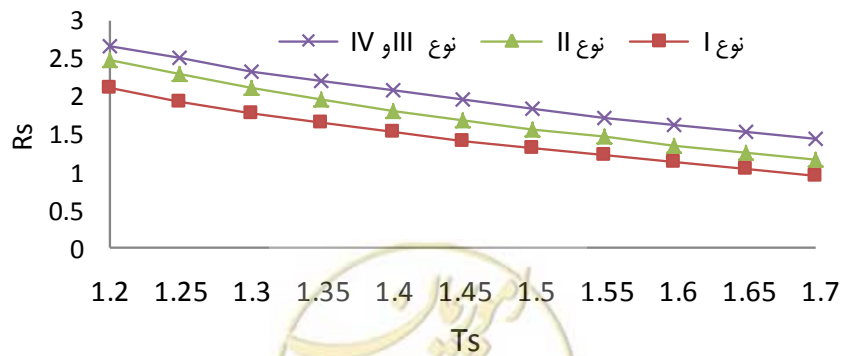

Figure 10-2: Response characteristic coefficient related to the shearing coefficient at the level and the moment coefficient at the level, R_s and R_m , in the suspended type tower (perpendicular direction)



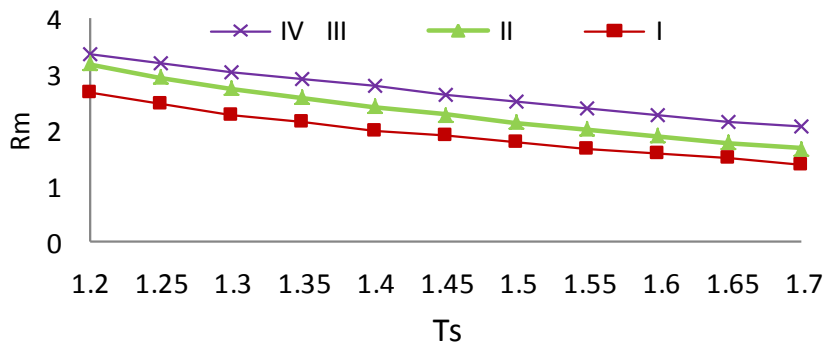

Figure 10-3: Response characteristic coefficient related to the shearing coefficient at the level and the moment coefficient at the level, R_S and R_M , in the tensile type tower (parallel direction)

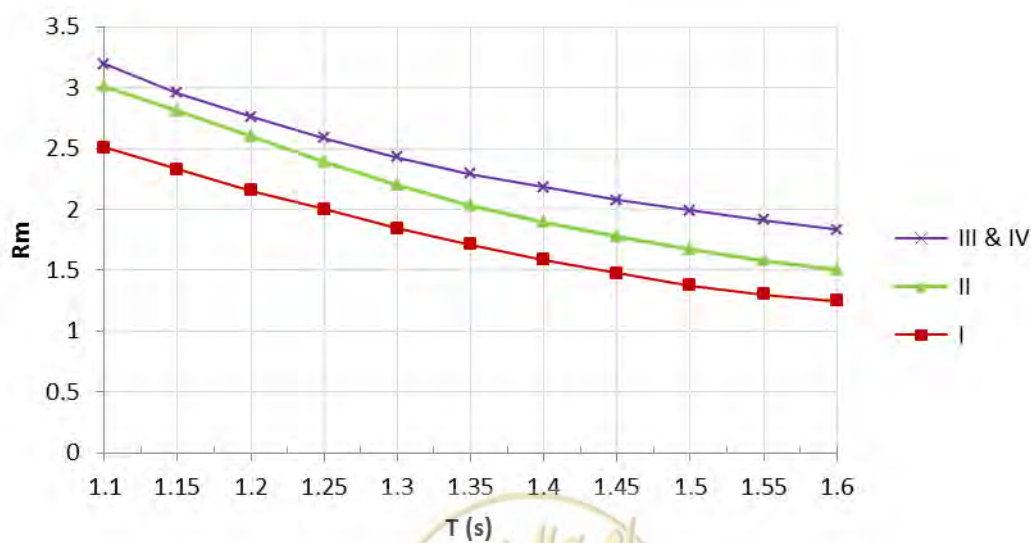
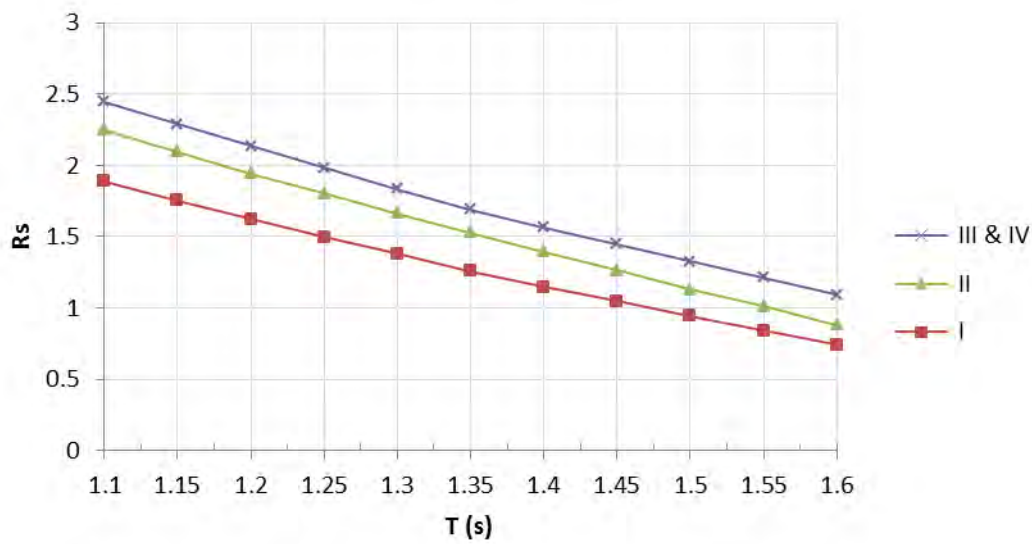
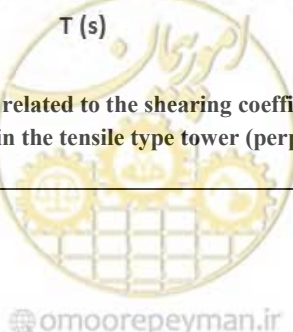

Figure 10-4: Response characteristic coefficient related to the shearing coefficient at the level and the moment coefficient at the level, R_S and R_M , in the tensile type tower (perpendicular direction)



10-3-1-4- Distribution coefficient related to the shearing and moment coefficient at the tower level

Distribution coefficient related to the shearing and moment coefficient at the tower level is calculated using Figures (10-5) – (10-8). In these figures:

W_i : Weight of the upper section of the tower from h_{bi} (t)

W : Total weight of the tower (effective weights such as weight of the wiring must be considered) (t)

H_i : Distance of h_{bi} from the center of gravity of the upper section (m)

H_b : Distance of the tower center of gravity from the bottom of the tower

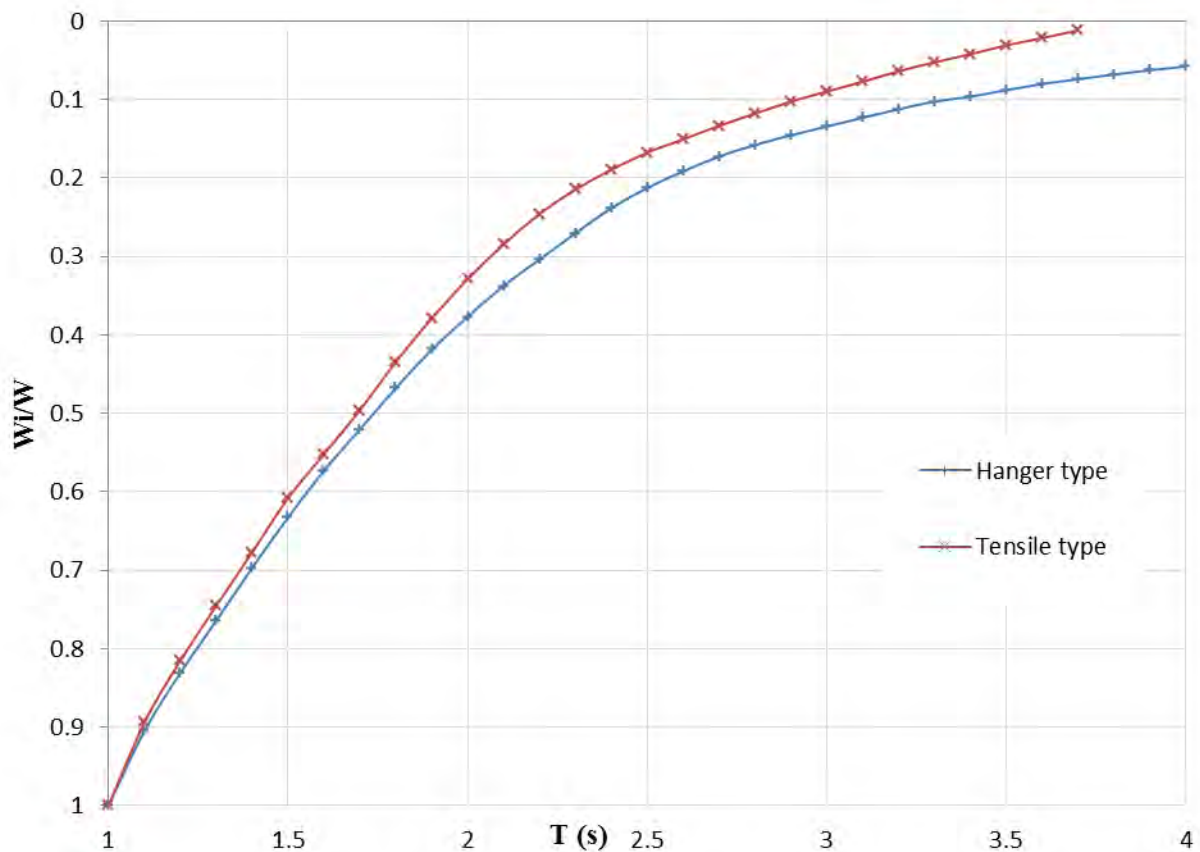
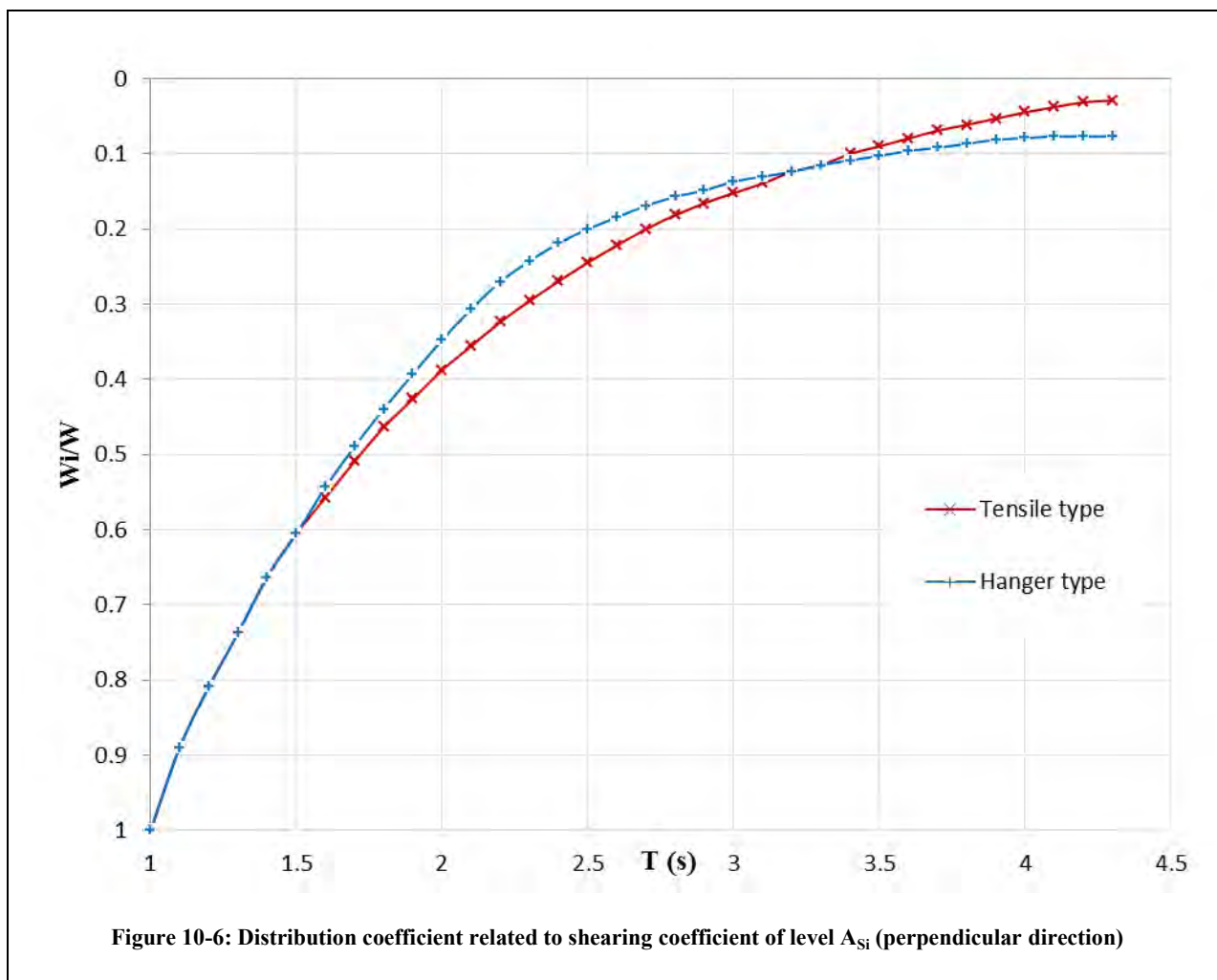
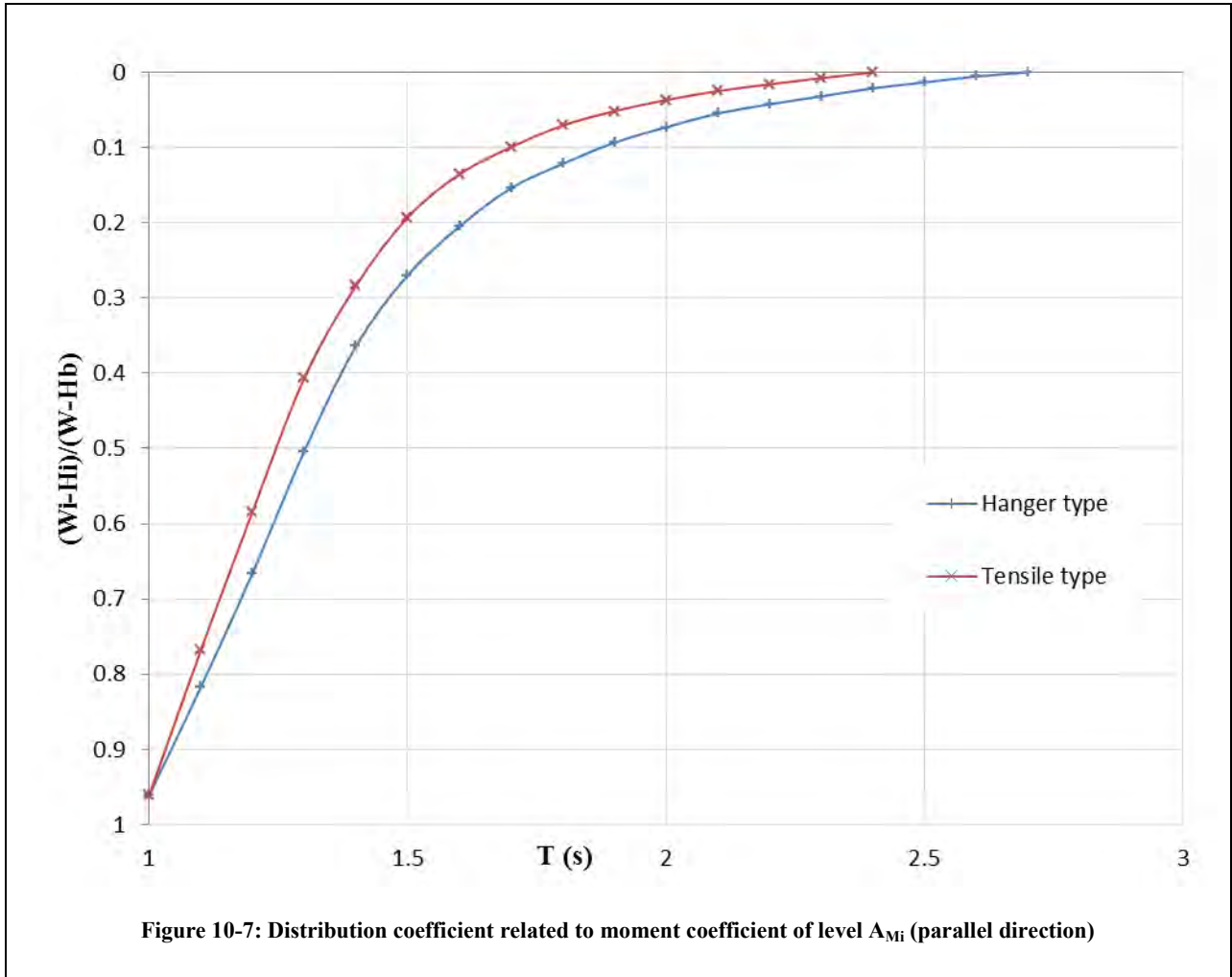
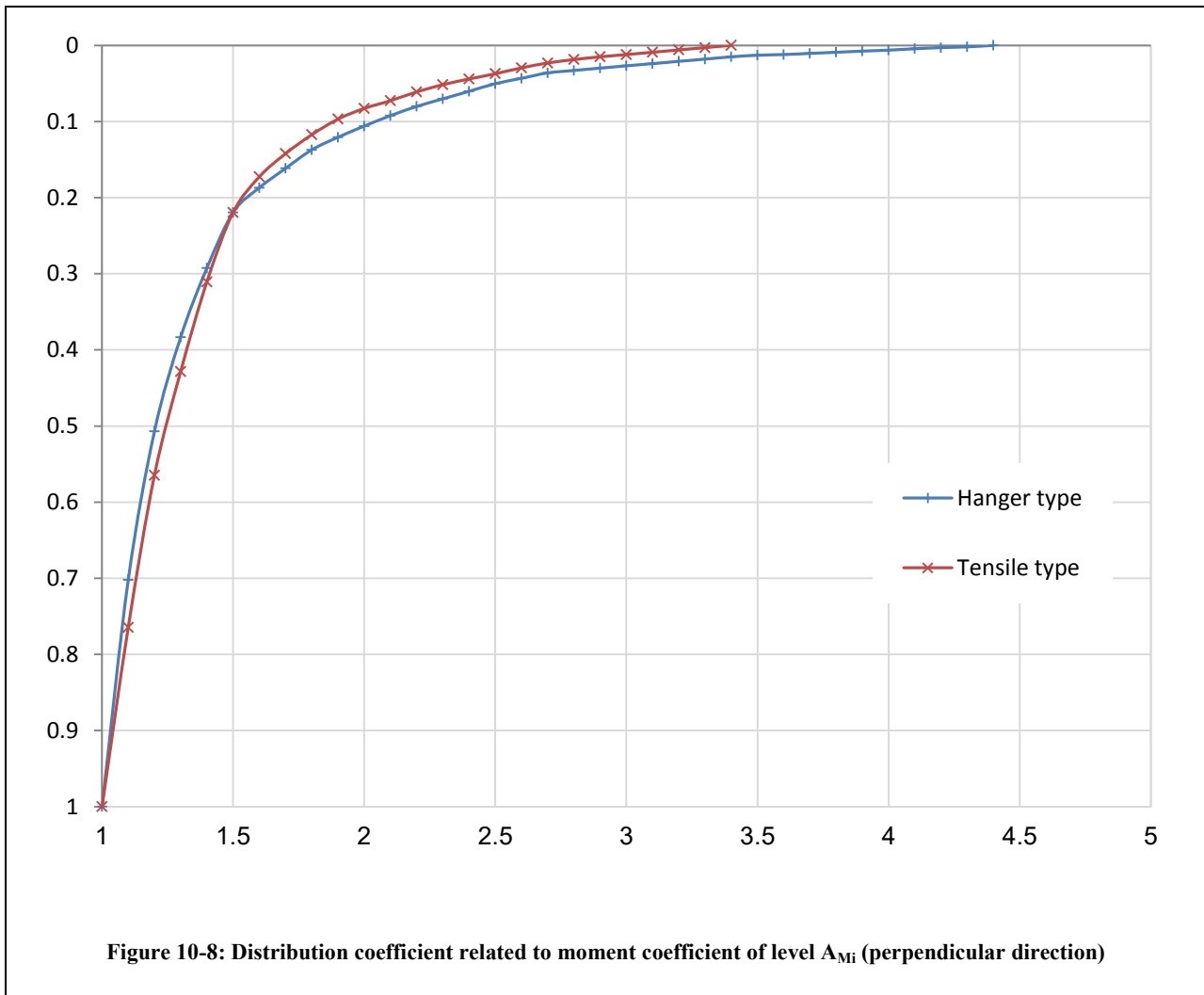

Figure 10-5: Distribution coefficient related to shearing coefficient of level A_{Si} (parallel direction)









10-3-1-5- Distribution coefficient related to the arm shearing and moment coefficients

Distribution coefficient related to the shearing coefficient of level A_{ASi} and distribution coefficient related to the moment coefficient of level A_{AMi} of the arm is calculated through Figures (10-9) – (10-11). In these figures:

W_i : Weight of the upper sections from h_{bi} (t)

W : Total weight of the tower (effective weights such as weight of wiring must be taken into consideration)

H_i : Distance of h_{bi} from the center of gravity of the upper section (m)

H_b : Distance of the tower center of gravity from the bottom of the tower.



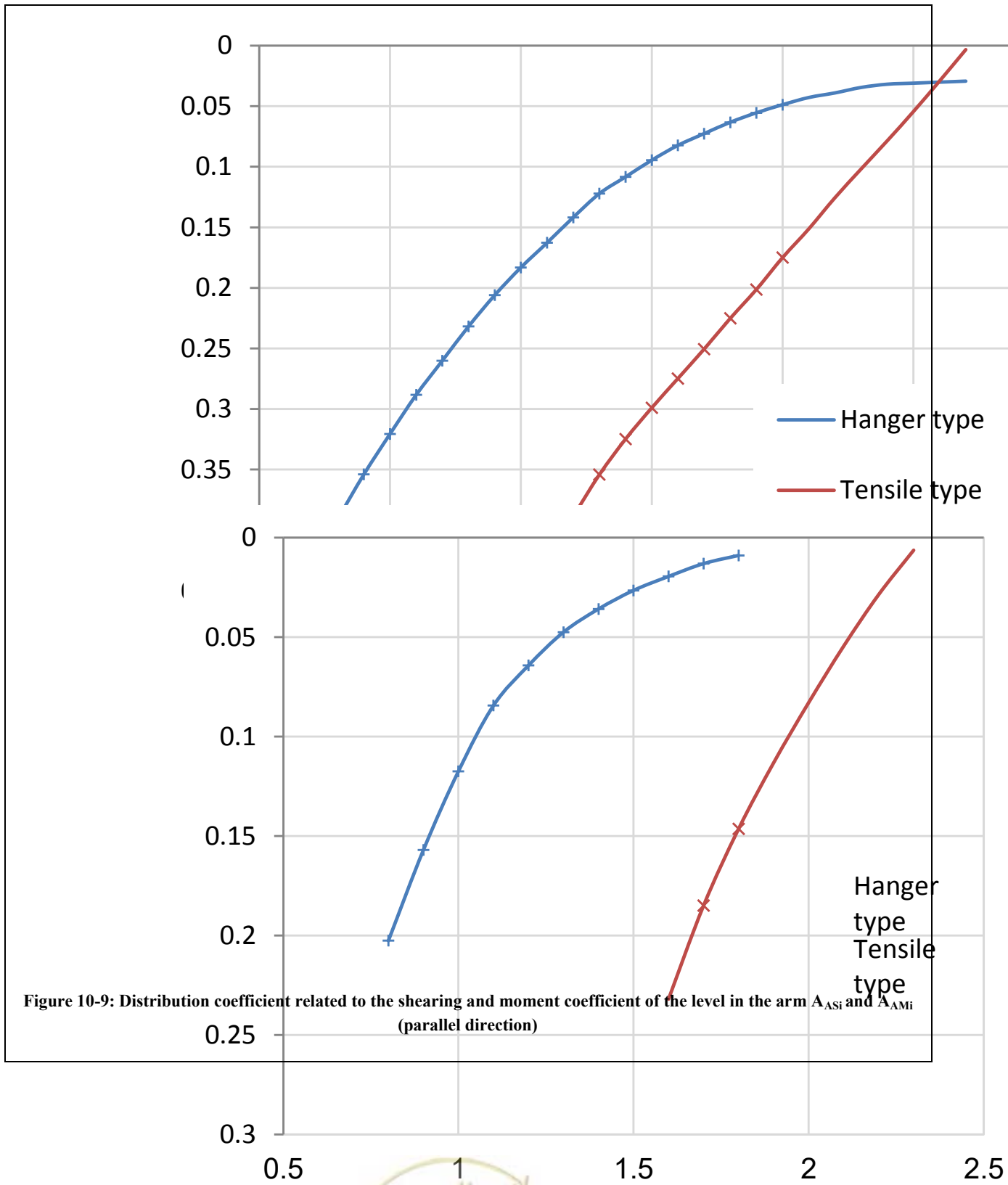

Figure 10-9: Distribution coefficient related to the shearing and moment coefficient of the level in the arm A_{ASi} and A_{AMi} (parallel direction)



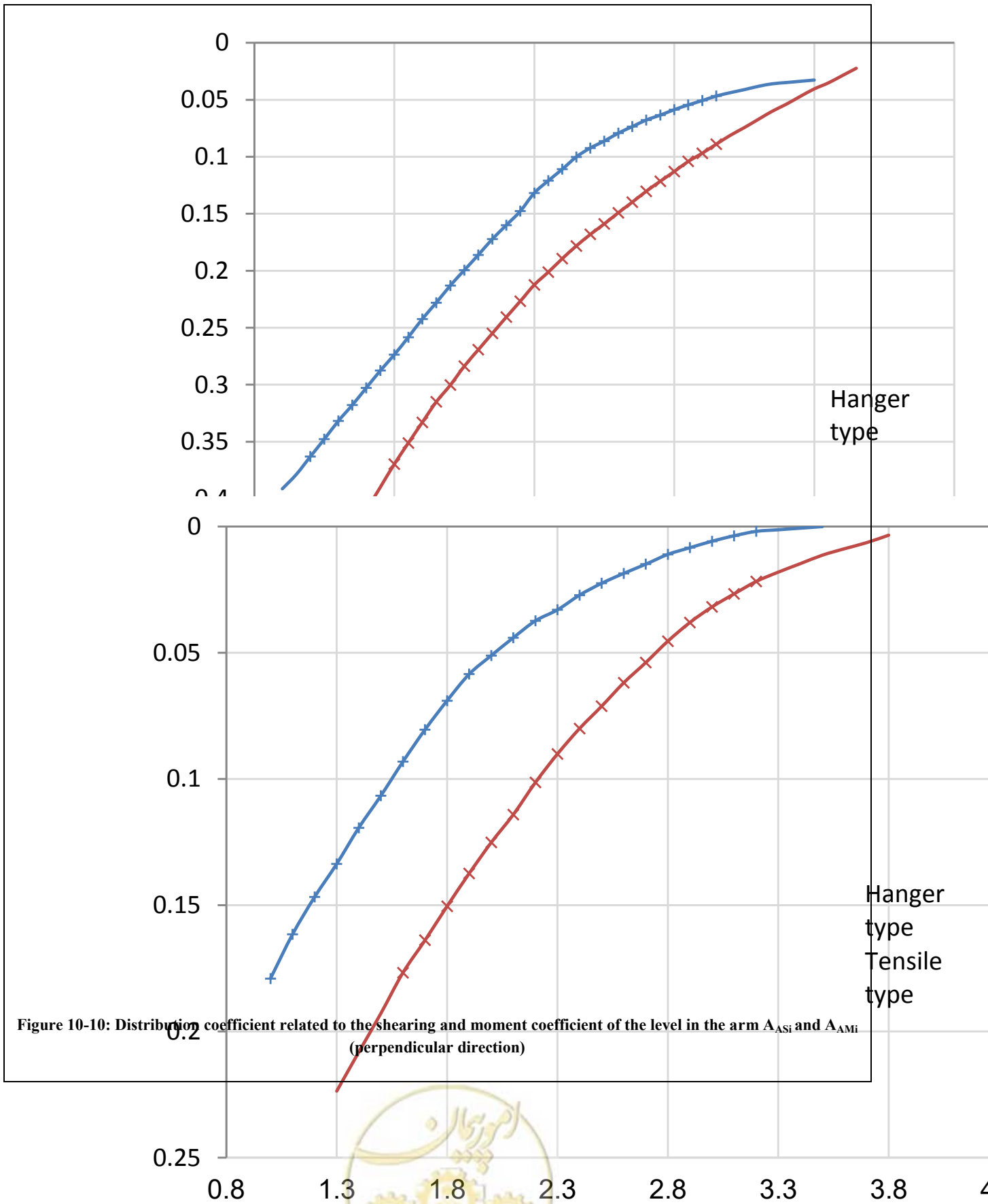
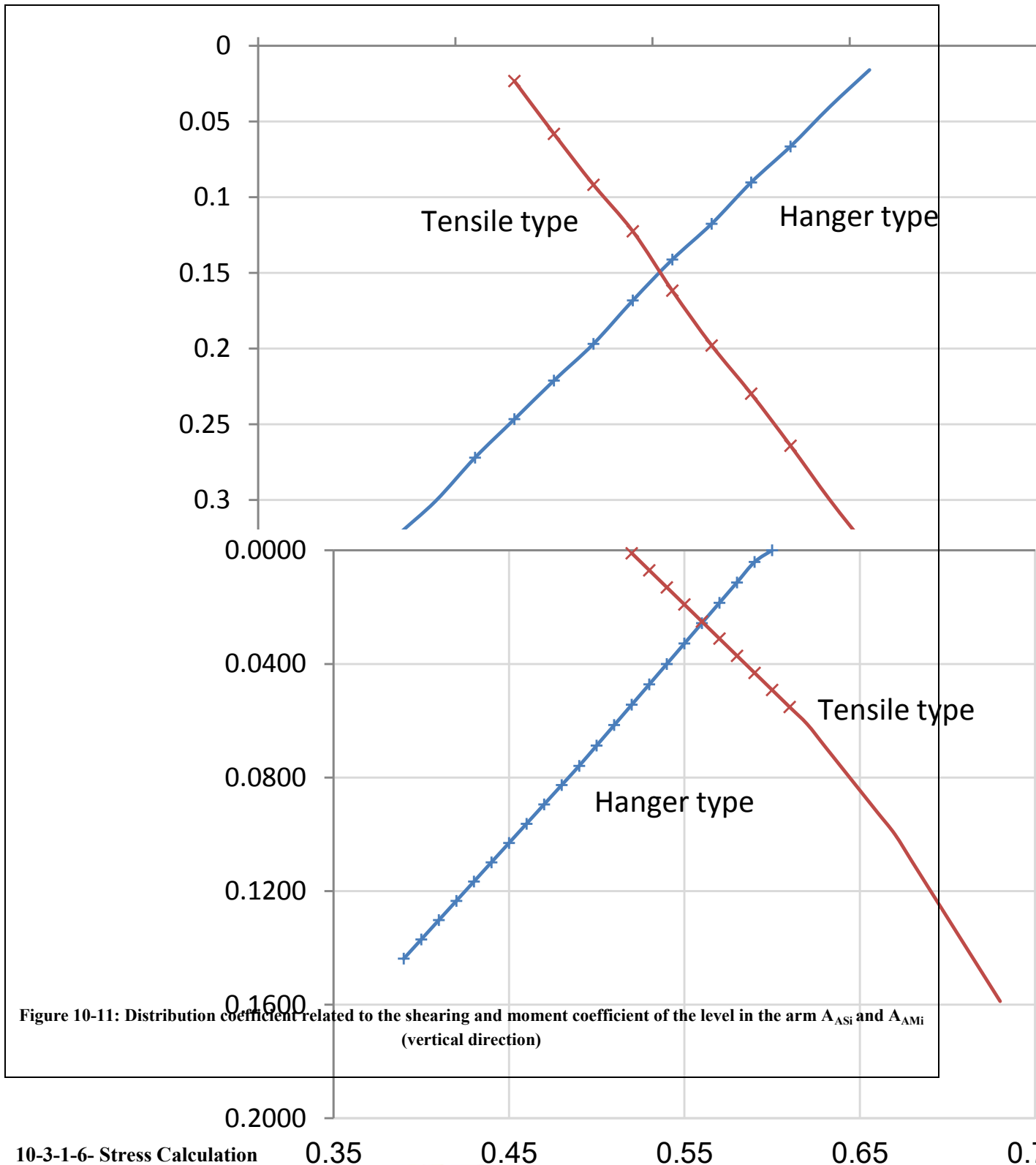

Figure 10-10: Distribution coefficient related to the shearing and moment coefficient of the level in the arm A_{ASi} and A_{AMi} (perpendicular direction)





10-3-1-6- Stress Calculation

The stress caused by the earthquake must be calculated using the shearing force and moment of the level. For the tower arm, the seismic force must be considered in horizontal and vertical directions. The component stress must be calculated considering the combination of stresses caused by the dead load, tensile load of the wiring, and the stress caused by the earthquake.

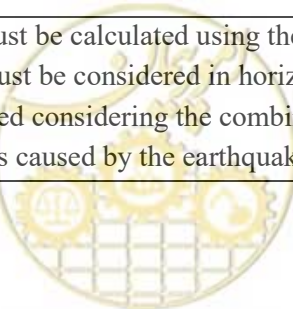

Safety evaluation must be performed through comparing the combined stress with to the allowable stress.

10-3-1-7- Foundation design load calculation

- 1-Foundation load is calculated by combining the seismic effect with the effects of the dead load and tensile load of the wiring.
- 2-Seismic loads must be considered in horizontal and vertical directions.
- 3-Chapter 9 of the National Construction Code of Iran or ABA can be used in foundation design,

10-3-2- Utility poles in Distribution Network

1-Wind load calculation

Load of the wind and its distribution is calculated according to the Chapter 6 of the National Construction Code of Iran.

2-Cable tensile force

Tensile force of the cable is calculated through Equation (10-14).

$$T = W_L \cdot S^2 / (8 \cdot d) \quad (10-14)$$

T: Tensile force (KN)

d: Cable uplift (m)

W_L : Effective weight of one meter of the cable (N/m)

S: Length of the span (m)

Cable uplift is indeed the curvature of the cable as shown in Figure (10-12).

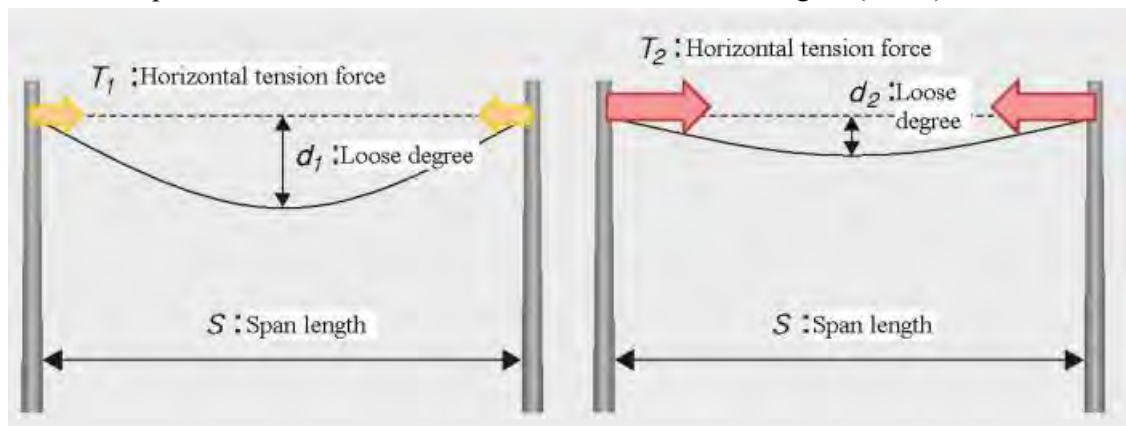

Tension force $T_1 < T_2$

Loose degree $d_1 > d_2$

Figure 10-12: Loose degree and tensile force

Effective weight of cable per unit length is calculated as shown in Figure 10-13.

$$W_L = \sqrt{w^2 + P_c^2}$$

(10-15)

W_L : Effective weight of the cable per unit length (N/mm)

P_C : Wind load per unit length (N/m)

w : weight of cable per unit length (N/m)

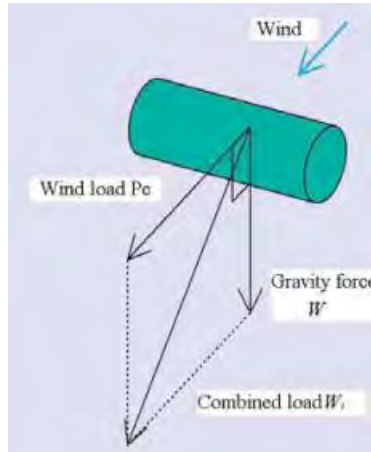

Figure 10-13: Convolution of wind load and gravity force

To figure out the environment temperature in cable design, maximum tensile force in the lowest temperature must be calculated.

3-Vertical force calculation

Weight of the pier, weight of the electrical panel equipment including connections under snow and freezing conditions, weight of various wires under snow and freezing conditions, weight of the vertical component of the supporting wire, and weight of the workers and tools must be taken into consideration in vertical force calculation.

4-Load action point

Force and moment balance conditions as shown in Figure 10-14 must be taken into consideration in design calculations. Balance force at a given point is determined through promoting moment balance at the pier foundation.

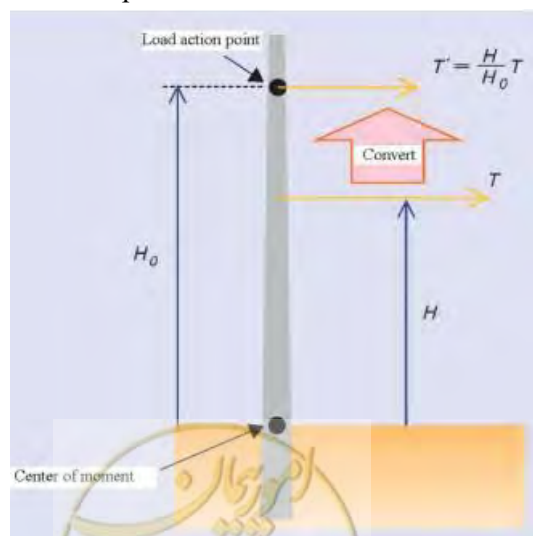

Figure 10-14: Load action point

5-Types of utility pole

5-1- Material

In a distribution network the poles are either steel or concrete.

Concrete poles are divided to type-1 and type-2 poles.

Type-1 is used for critical transmission facilities and communication lines, and type-2 is used for the railways.

5-2- Shape

As shown in Figure 10-15 the lower end has a bigger section than the upper end. Conic slope of the pole – α – is calculated through equation (10-16).

$$\alpha = (D' - D)/L \quad (10-16)$$

Value of α is assumed 1.75 for both steel and concrete poles.

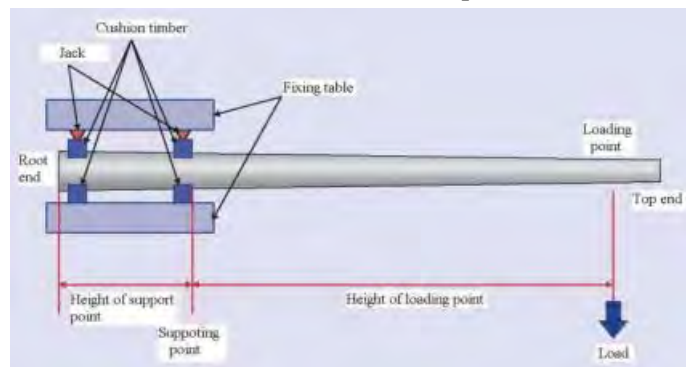

Fig. 10-15: Calculation of conic angle of the pole (left)

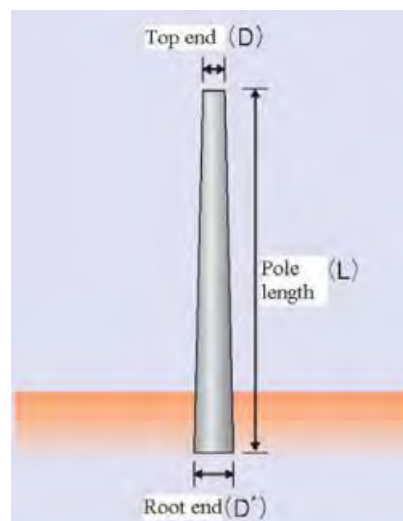

Fig. 10-16: Pole bending test

As shown in Figure 10-15, maximum bending moment is generated at a point on the borderline between aboveground and underground sections of the pole.

Sectional area of the pole at the border point is decisive.

5-3- Failure modes and pole strength

Pole failures take place in two forms.

The first form is when the pole breaks. This happens when the ground is rigid and the maximum moment caused by the load is bigger than the allowable moment of the pier.

Second form is when the pole overturns. In this case the ground is soft and allowable load capacity of the ground is smaller than the maximum moment.

- Pole strength

Allowable strength of the pole is determined through the test shown in Figure 10-16.

Maximum force (horizontal force) is the allowable strength (design force) of the pole.

Cracks bigger than 0.25 mm are not expected to appear under the maximum design load.

Waste cracks with no load must not exceed 0.05 mm.

Failure force is twice of the maximum design force.

As shown in figure (10-17), to avoid cracks in the concrete pole, post tensioned steel bars are used in most cases. These poles are known as PC poles.

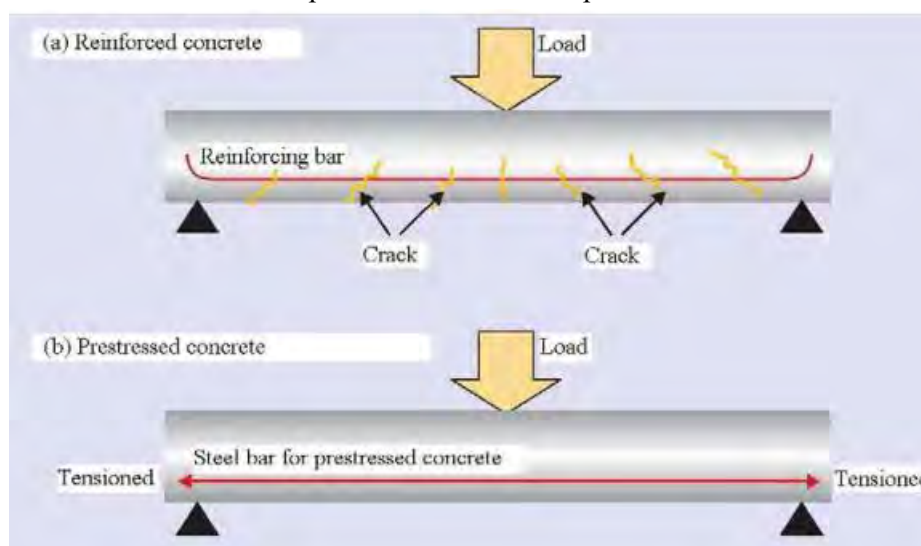

Figure 10-17: Post tensioned pole

Design force of the steel poles is controlled like that of the concrete poles. The buckling control is performed through the related tests.

- Supporting ground load capacity

Moment M_{ot} at the rotating center of the pole is calculated through Equation (10-17).

$$M_{ot} = P \cdot (h + t_o) \quad (\text{kN.m}) \quad (10-17)$$

P: Wind Force (kN)

h: height of the load from the ground level (m)

t_o : depth of the rotating center under the ground level

Ultimate moment generated before the pole overturns is called the ultimate resistant moment M_{oa} .

$$M_{ot} \leq M_{oa} \quad (10-18)$$

Figure 10-18 explains the above equation.

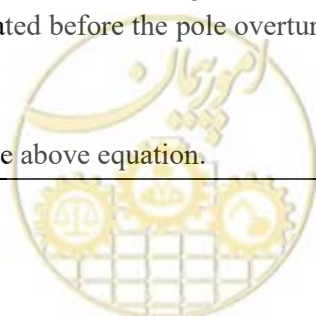

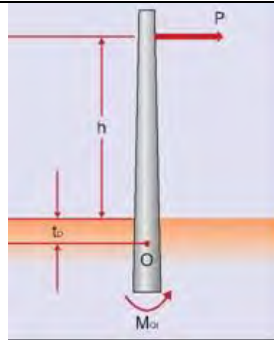

Figure 10-18: Moment generated at the rotating center

- Depth of buried pole

Deeper the pole is buried the more value of M_{oa} for resisting against moment M_{ot} would be. Calculated value of M_{oa} must be checked with the site conditions.

5-4- Seismic design

The above explanations are basically related to the pole design against wind load of P.

In this design the applied force P' is determined against the seismic load. This value replaces the value of P in Equation 10-19.

Value of P' shall not be combined with that of P. The moment M_{ot} caused by P' or P is calculated and the bigger one is taken into consideration.

$$P' = K_{SH} W_s \quad (10-19)$$

K_{SH} : Horizontal seismic coefficient

W_s : Weight of the tower

Vertical component of earthquake is disregarded.

10-4- Allowable quantities

1-Allowable stress

Allowable stress in equivalent static method, displacement response analysis method, and level shearing coefficient analysis method is assumed 1.5 times of the allowable stress caused by the normal load under operation conditions.

2-Foundation displacement

2-1- foundation displacement on the soft ground

- When the earthquake is parallel or perpendicular to the line direction, displacement between the poles, when the shearing wave spreads in direction of the movement, is disregarded.
- When the earthquake has a 45 degree angle with the line direction, the relative displacement of the poles must be calculated.
- Standard allowable displacement is around $\frac{1}{800}$ at the tower base span.
- 2-2- Displacement on the normal ground
- Displacement of the foundation on the normal ground due to the movement of the surface wave is

insignificant.

- When the tower piers are set up in mountainous areas, or when the ground slope changes frequently, excessive stress is generated in the tower components.
- Allowable displacement of the foundation on the normal ground is 1.5 times of the allowable displacement in operation conditions; which equals 15mm for each pole.
- Since displacement of extensive foundations on favorable ground is insignificant, displacement control is not required.

10-5- Function Range

1-Characteristic of the main component of the pole and steel tower must comply with Table 10-3:

Table 10-3: Slenderness ratio

| Support type | Component | Slenderness ratio |
|--------------------------|--|-------------------|
| Steel pole / steel tower | Main post (including material and arm) | 200 or less |
| | Compressive components other than the main post | 220 or less |
| | Spare part (used as a compressive component) | 250 or less |

Table 10-4: Component thickness (JESC E0008)

| Support type | | Part | Thickness (mm) |
|--------------|-----------------------|------------|----------------|
| Steel pole | Steel raiser sheet | Post | 1 or more |
| | Steel pier | Post | 2 or more |
| | Other steel poles | Main / arm | 4 or more |
| Other | | 3 or more | |
| Steel tower | Steel pipe | Main / Arm | 2.4 or more |
| | | Other | 1.6 or more |
| | Other than steel pipe | Main / Arm | 5 or more |
| | | Other | 3 or more |

2-Bolts used in the steel poles and towers are procured after the operator's approval.



Appendixes



Appendix 1

Allowable stress in seismic design is determined for the part in use in the target structure, and shall be determined for compressive and non-compressive materials separately in the support structure system.

1-1-Allowable Stress for Compressive Materials Seismic Design

Allowable stress in compressive materials seismic design is calculated based on the type of stress and through multiplying a coefficient by the tensile strength S_U or the 0.2% proof strength in the design temperature.

Table-1: Allowable stress for compressive materials seismic design

| Type of Stress | Allowable Stress for Seismic Design |
|--------------------|--|
| Tensile Stress | S (for welded materials S must be multiplied by η_w) |
| Bonding Stress | S |
| Compressive Stress | Minimum S or S' |
| Shear Stress | 0.6S |

Note: In this table values of S, S' , and η_w are calculated as shown below.

S is the allowable stress for compressive materials seismic design; and its value based on the type of the materials shown in the left column is shown in the right column of Table-2. (N/mm²)

Table-2: Allowable stress for seismic design based on the type of the materials

| Material | S |
|--|--|
| Materials with aluminum alloy and steel materials with 9% nickel to be used in temperatures less than the room temperature | $S = \min \{0.6S_u, 0.9S_y\}$ |
| Austenite stainless steel materials and steel materials with high nickel alloy to be used in temperatures higher than the room temperature | $S = \min \{0.6S_{u0}, 0.6S_u, 0.9S_{y0}, S_y\}$ |
| Materials other than (a) and (b) | $S = \min \{0.6S_{u0}, 0.6S_u, 0.9S_{y0}, S_y\}$ |

S' is the allowable stress related to deformation in compressive material seismic design, which is indicated in the right column of Table 3, based on the type of materials shown in the left column. (N/mm²)



Table-3: Allowable stress related to deformation

| Material | S' |
|--|---|
| Horizontal cylindrical reservoirs and towers | $\frac{0.6Et}{\left(1 + 0.004\frac{E}{S'_y}\right)D_m}$ |
| Cylindrical reservoirs | $\frac{Et}{3D}$ |

η_w Welding adequacy

S_u Tensile strength in the design temperature of 0-40°C, which must be less than the minimum value of the standard materials

S_{u0} Tensile strength in the ambient temperature, which must be less than the minimum value of the standard materials

S_y Yield strength or the 0.2% proof strength in the design temperature of 0-40°C, which must be less than the minimum value of the standard materials

S_{y0} Yield strength of the 0.2% proof strength in the ambient temperature of 0-40°C, which must be less than the minimum value of the standard materials.

S'_y Minimum value of S_y or S_{y0} (N/mm²)

E Module of elasticity of the material in design temperature (N/mm²)

D_m Average diameter of the skin (mm)

t Average thickness of the skin

D Inner diameter of the reservoir (mm)

1-2-Allowable Stress for Support Structure Materials Seismic Design

The allowable stress in support structure material seismic design is calculated through multiplying minimum coefficient of 70% by the tensile strength and yield strength, or the 0.2% proof strength, or the tensile strength in the design temperature, based on the type of stress.

According to KHK standard of Japan, the allowable stress of the steel materials in support structures would be as shown below.

1-2-1- Support Structure Materials

For seismic design, the allowable stress of the support structures (N/mm²), which are not directly welded to the compressive materials, is shown in the right column of Table-4, based on the type of stress, shown in the left column.

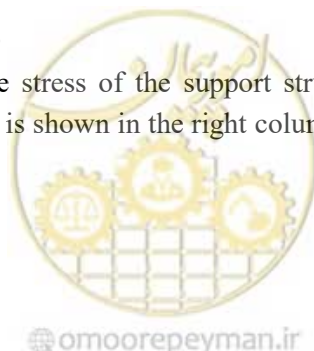

Using the control equation shown in the right column of Table-6, in support structure materials, the compound stress must be controlled based on the type of the compound, shown in the left column of this table.

Table-4: Allowable stress for support structures seismic design

| Type of Stress | Allowable Stress for Seismic Design | |
|--------------------|--|------------------------|
| Tensile Stress | F | |
| Compressive Stress | F | |
| Compressive Stress | Skirt Stress | Min Value of \bar{S} |
| | Saddle Stress | F |
| | Support structure materials other than (a) and (b) | Min Value of \bar{F} |
| Shear Stress | $\sqrt{3}F$ | |

F Minimum value of 70% of yield strength or 0.2% proof strength or tensile strength of the materials (N/mm²)

F' Allowable compression stress for buckling check considering the slenderness ratio of the material (N/mm²)

S' The value calculated in Table-3

Note: Allowable compression tension F for buckling check is determined based on the slenderness ratio.

If $\lambda_s \leq \Lambda$

$$F' = \frac{1.5 \left\{ 1 - 0.4 \left(\frac{\lambda_s}{\Lambda} \right)^2 \right\} F}{\nu} \quad (1)$$

If $\lambda_s > \Lambda$

$$F' = \frac{1.5 \times (0.277F)}{\left(\frac{\lambda_s}{\Lambda} \right)^2} \quad (2)$$

λ is the slenderness ratio of the compressive element, which is calculated through Equation-3.

$$\lambda_s = \frac{l_k}{i} \quad (3)$$

l_k : Is the buckling length (mm), which is calculated in Table-5, based on the type of the edge supports?

i : is the second radius of area of buckling axis

Table-5: Buckling Length



| Condition of movement | Constraint | | |
|-----------------------|---------------------|----------------------|--|
| Condition of rotation | Both ends are free. | Both ends constraint | One free edge and other end constraint |
| l_k | l | $0.5l$ | $0.7l$ |

Λ : Limit slenderness ratio and the value obtained by the next expression.

$$\Lambda = \sqrt{\frac{\pi^2 E}{0.6F}} \quad (4)$$

E: Modulus of longitudinal elasticity of the material (N/mm²).

ν : Value obtained by the next equation

$$\nu = \frac{3}{2} + \frac{2}{3} \left(\frac{\lambda_s}{\Lambda} \right)^2 \quad (5)$$

Table (6) Combination of stress

| Type of combination of stress | Judging equation |
|--|--|
| Combination of compressive stress and bending stress | $\frac{\sigma_c}{f_c} + \frac{\sigma_b}{f_b} \leq 1$ |
| Combination of tensile stress and bending stress | $\frac{\sigma_t}{f_t} + \frac{\sigma_b}{f_b} \leq 1$ |
| Combination of compressive stress, bending stress, and shearing stress | $\sqrt{(\sigma_c + \sigma_b)^2 + 3\tau^2} \leq f_t$ |
| Combination of tensile stress and shearing stress (Limit to the anchor bolt) | $\frac{\sigma_t + 1.6\tau}{1.4} \leq f_t$ |

Remarks, f_c , f_b , f_t , σ_c , σ_b , σ_t and τ are to be the following value respectively in the table above.

f_c : Allowable compressive stress for seismic design of support structure material. Value provided in Table 6 (N/mm²)

f_b : Allowable bending stress for seismic design of support structure material. Value provided in Table 6 (N/mm²)

f_t : Allowable tensile stress for seismic design of support structure material. Value provided in Table 6 (N/mm²)

σ_c : Compressive stress caused in support structure material (N/mm²)

σ_b : Bending stress caused in support structure material

σ_t : Tensile stress caused in support structure material

τ : Shearing stress caused in support structure material

1-2-2- Support structure material welded directly by pressure part material

As for the support structure material welded directly to the pressure part material, the allowable stress as the pressure part material is also applied.

Because it is necessary to have the function as the support structure material, it is necessary to suit the following conditions.

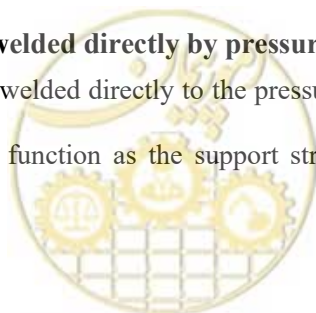

1- Allowable stress for the seismic design is to be smallest value among the values obtained from Table (1) to (5).

2-When combined stress is caused, it should suits the judging equation of combined stress by Table (6).

1-3-Allowable stress for seismic design of foundation material

The following are allowable stress for foundation material of KHK of JAPAN.

1-3-1- Allowable stress of concrete for seismic design

The allowable stress of concrete for seismic design is to be a value in a right column of the table according to the type of the stress in a left column in the table below.

Table 7 Allowable stress of concrete for seismic design

| Type of stress | Allowable stress for seismic design | | |
|--------------------|--|-------------------|---|
| Compressive stress | $2F_c/3$ | | |
| Shearing stress | $F_c/20 \left(0.735 + \frac{3F_c}{200} \right)$ under | | |
| Bond stress | Round bar | Top reinforcement | $6F_c/100$ |
| | | Other rebar | $9F_c/100$ |
| | Deformed reinforcing bar | Top reinforcement | $F_c/10 \left(1.32 + \frac{F_c}{25} \right)$ |
| | | Other rebar | $3F_c/20 \left(2.00 + \frac{3F_c}{50} \right)$ |

Remarks,

1- F_c in this table shows design strength of concrete on the 28th (N/mm^2).

2- Concrete tensile strength is assumed to be 0.

3- The adhesion of the anchor bolt is assumed to be a value of other rebar. The value of top reinforcement is adjusted to 2/3 of the values of other rebar because the adhesion of concrete under top reinforcement is not in good condition.

1-3-2- Allowable stress of rebar for seismic design

The allowable stress for the seismic design of the rebar is to be a value in a right column according to the type of the stress in a left column in the table below.

Table 8 Allowable stress for seismic design of rebar

| Type of stress | | Allowable stress for seismic design |
|--------------------|---------------------------------|--|
| Compressive stress | | F |
| Tensile stress | use besides shear reinforcement | F |
| | use for shear reinforcement | F (When a value exceeds 294, set 294.) |

F in this table shows yield strength (N/mm^2) of the rebar.

1-4- Allowable stress for seismic design of piping material

The allowable stress for the seismic design of a piping and its support structures(or piping system) is set to the piping, the flange joint, the valve, the expansion joint, and the nozzle respectively.

The following are allowable stress for piping material of KHK of JAPAN.

1-4-1- Allowable stress for seismic design of piping

Table 9 Allowable stress for seismic design of piping

| Type of stress | Allowable stress for seismic design |
|-------------------------------|-------------------------------------|
| Longitudinal stress of piping | S |
| Cyclic Stress range | $2S_y$ |

1-4-1- Allowable stress for seismic design of flange joint

Table 10 Allowable stress for seismic design of flange joint

| Type of stress | Allowable stress for seismic design |
|----------------------------------|-------------------------------------|
| Radial stress of flange | S |
| Circumferential stress of flange | S |
| Axial stress of hub | $2S_y$ |



1-4-2- Allowable stress for seismic design of valve

Table 11 Allowable stresses for seismic design of valve

| Type of valve | Allowable stress for seismic design |
|-------------------------------------|-------------------------------------|
| Important earthquake shut-off valve | $0.5S$ |
| Other valves | S |

1-4-3- Allowable stress for seismic design of expansion joint

Value twice allowable stress amplitude repeatedly obtained in 1993 Japanese Industrial Standards B8281 "Stress analysis and failure analysis of pressure vessel" corresponding to 500 load cycles.

1-4-5- Allowable stress for seismic design of nozzle connected to towers and tanks

Table (11) Allowable stresses for seismic design of towers and tanks

| Type of strength of stress | Allowable stress for seismic design |
|---|-------------------------------------|
| (a) Strength of primary general membrane stress | S |
| (b) Sum of primary local membrane stress and first bending stress | $1.5S$ |
| (c) Difference between the maximum value and minimum value of sum of the primary local membrane stress strength, the primary bending stress strength and secondary stress strength at cycle | $2S_y$ |



2-1- Inner tank

2-1-1-side plate of inner tank

2-1-1-1- Yield seismic intensity of compressive stress of side plate due to earthquake level-2

The yield seismic intensity of the compressive stress of the side plate for level-2 of earthquake is calculated by the following equation.

$$K_{yc2} = K_{MH2} \frac{S_c + \sigma_{t0} - \sigma_{c0}}{\sigma_{cE2}} \quad (6)$$

K_{yc2} : Yield seismic intensity of buckling of side plate

S_c : Value obtained from the following equation by buckling stress(N/mm²)

$$S_c = \frac{E_t}{2.5D_1 t} \quad (7)$$

E_t : Modulus of longitudinal elasticity at design temperature of material(N/mm²)

t : Side plate board thickness at position in which stress is calculated(mm)

D_1 : Side plate internal diameter(mm)

σ_{r0} : Average axial tensile stress by internal pressure, value obtained from the following equation (N/mm²)

$$\sigma_{r0} = \frac{P_0 D_1}{4t} \quad (8)$$

P_0 : The lowest pressure in usual operating state(MPa)

D_1 : Side plate internal diameter(mm)

t : Side plate board thickness at position in which stress is calculated(mm)

σ_{r0} : Average axial compression stress by self-weight at position in which stress is calculated, value obtained from the following equation(N/mm²)

$$\sigma_{c0} = \frac{(W_r + W_s)}{\pi D_1 t} \quad (9)$$

W_r : All self-weight of roof sheathing(N)

W_s : Self-weight of side plate that acts on position in which stress is calculated(N)

D_1 : Side plate internal diameter(mm)

K_{MH2} : Design modification horizontal seismic coefficient

$$K_{MH2} = \frac{9\alpha_{H2}}{g} \quad (10)$$

g : Gravity acceleration(cm/s²)

α_{H2} : Horizontal acceleration in ground level of type-2 design earthquake motion and value obtained from the following table according to the division of the first natural period of sloshing of the content fluid.(cm/s²)

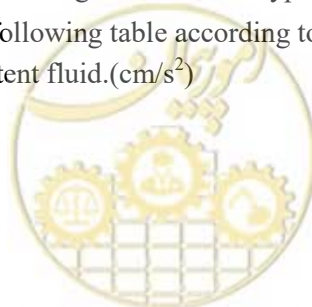

Table (13) First natural period of sloshing T and α_{H2}

| T(s) | α_{H2} |
|--------------------------------------|---------------------------------------|
| $7.5 \frac{\alpha_d}{\alpha_v}$ less | $V_H \frac{2\pi}{T}$ |
| $7.5 \frac{2\pi}{T}$ over | $D_H \left(\frac{2\pi}{T} \right)^2$ |

T : First natural period of sloshing of content fluid(s)

V_H : Horizontal seismic velocity in ground level(cm/s)

D_H : Horizontal ground motion displacement amplitude in ground level(cm)

α_d : Coefficient based on horizontal ground motion displacement in ground level, for MCE level earthquake α_d is over 1.0 (in principal set as 1.0)

α_v : Coefficient based on horizontal ground motion velocity in ground level, for MCE level earthquake α_d is over 1.0 (in principal set as 1.0)

Sc, σ_{t0} , σ_{c0} : Values provided in 1) a) i) (i).

σ_{cE2} : Compressive stress by overturning moment in height h when type-2 design earthquake motion of 1G acts horizontally, and obtained by the next equation.(N/mm²)

$$\sigma_{cE2} = K_{MH2} \frac{4(1 - h / H_1)^{1.3} W_2 H_2}{\pi D^2 t} \quad (11)$$

W_2 : Weight of effective liquid of content fluid due to type-2 design earthquake motion, and obtained by next equation.

$$W_2 = f_2 \cdot W_1 \quad (12)$$

f_2 : Rate of weight of effective liquid due to type-2 design earthquake motion, and obtained by Fig. (1) according to the value of H_1/D .

W_1 : Weight of content fluid(N)

H_2 : Height of gravitational center of effective liquid of content fluid that lies type-2 design earthquake motion and obtained by next equation. (N)

$$H_2 = h_2 \cdot H_1 \quad (13)$$

h_2 : Value obtained by Fig. (1)

h, H_1 , D, t : Values provided in 1) a) i) (ii)



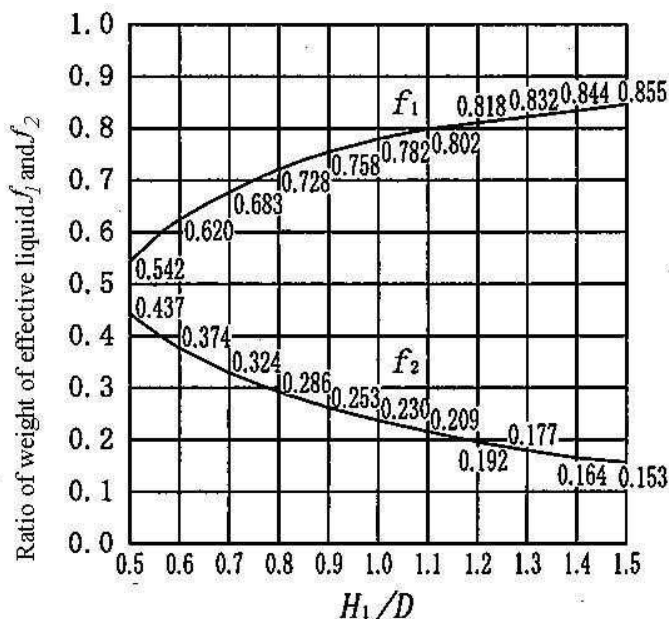

Fig. (2) H_1/D_1 and effective weight rate f_1, f_2

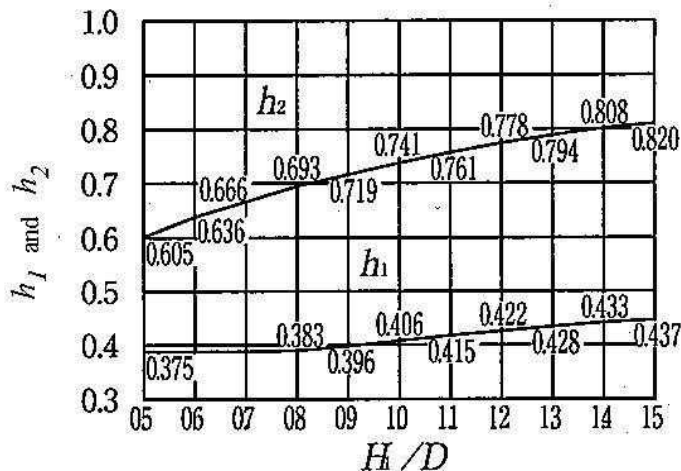

Fig. (3) H_1/D_1 and h_1, h_2

2-1-1-2- Allowable ductility factor

For, $\sigma_0/S_c \leq 0.2$,

$$\mu_{pa} = 0.35 \tag{14}$$

For, $0.2 < \sigma_0/S_c$,

$$\mu_{pa} = 0.13 \tag{15}$$

μ_{pa} : Allowable ductility factor

σ_0 : Average axial compression stress, and obtained by next equation. (N/mm²)

$$\sigma_0 = \frac{(W_r + W_s)(1 + K_{MV}) - P_0 \pi R^2}{2\pi R t} \tag{16}$$



W_r, W_s, W_1, t, K_{MV} : Provided in 1) a) i) (ii)

R: Radius of side plate (mm)

P_0 : for (i), Lowest pressure in usual operating state for (ii), Maximum working pressure(MPa)

S_c : Provided in 1) a) i) (i)

2-1-2- Inner tank anchor

2-1-2-1-Yield seismic intensity related to tension

$$K_{yt2} = K_{MH2} \frac{S_{ya} - \sigma_{t0} + \sigma_{c0}}{\sigma_{tE2}} \quad (18)$$

K_{yt2} : Yield seismic intensity related to tension yielding of inner tank for hazard level -2

σ_{t0} : Tensile stress by internal pressure, and obtained by next equation. (N/mm²)

$$\sigma_{t0} = \frac{\pi D^2 P_0}{4 N A_p} \quad (19)$$

N : Number of inner tank anchor

A_p : Sectional area of inner tank anchor(mm²)

P_0 : Maximum working pressure(MPa)

D : Side plate internal diameter (mm)

σ_{c0} : Compressive stress by self-weight and obtained by next equation. (N/mm²)

$$\sigma_{c0} = \frac{W_s + W_r}{N A_p} \quad (20)$$

σ_{tE2} : Tensile stress by all overturning moments when Level-2 design earthquake motion acts and obtained by next equation. (N/mm²)

$$\sigma_{tE2} = K_{MH2} \frac{4 W_2 H_2}{D N A_p} \quad (21)$$

2-1-2-2- Allowable ductility factor

$$\mu_{pa} = \frac{\pi R_a q_y}{K_{yt}^2 (W_{IS} + W_r + W_1) g} \left(\frac{2\pi}{T_b} \right)^2 \frac{0.617 t_b S_{yb}^2}{E_a P_b} \quad (22)$$

However, $0.75 \leq \mu_{pa} \leq 2.5$

g : Gravity acceleration (mm/s²)

T_b : Natural period of tank by bulging vibration of side plate(s)

E_a : Modulus of longitudinal elasticity of inner tank anchor(N/mm²)

P_b : Pressure that acts on annular plate(MPa)

a_{qy} : Yield resistance of anchor of inner tank for each unit width, and obtained by next equation (N/mm)



$$a_{qy} = \frac{NAS_{ya} - \pi R^2 P_0}{2\pi R} \quad (23)$$

Here,

S_{ya} , N , A : Provided in 2) a) i)

P_0 : Highest pressure in usual operating state(MPa)

R : Radius of side plate(mm)

t_b : Board thickness of annular plate(mm)

S_{yb} : Yield stress of annular plate(N/mm²)

K_{yt1} , W_{1S} , W_r , W_1 : Provided in 2) a) i)

2-1-3- Inner tank nozzle

The ultimate strength design evaluation of the inner tank nozzle should be performed the evaluation related to the inertial force and the response displacement.

The stress of the appearance generated by the bending moment, the torsion moment, and the

Table (14) Allowable stress strength for seismic design of nozzle

| Damage mode | Type of stress intensity | Allowable stress strength for seismic design |
|--|--|--|
| Damage of nozzle by type-1 and type-2 design earthquake motion | The first local membrane stress strength + The first bending stress strength | 3S |
| | Difference between the maximum value and minimum value at the cycle of the sum of the primary stress intensity and the secondary stress intensity by the design seismic motion | 4S _y |

S : Allowable stress for seismic design

S_y : Yield point or 0.2% strength at design temperature of material(N/mm²)

2-2-Outer tank

The formula of the yield seismic intensity and the allowable ductility factor of outer tank side plate depend as follows.

2-2-1-Yield seismic intensity

The yield seismic intensity related to the compressive stress of the side plate by the type-1 design earthquake motion is calculated by the following equation.

$$K_{ycS2} = K_{MH2} \frac{S_c + \sigma_p - \sigma_o}{\sigma_{E2H}} \quad (24)$$

K_{yc1} : Yield seismic intensity of buckling of side plate by type-1 design earthquake motion

K_{KH} : Design modification horizontal seismic coefficient

S_c : Buckling stress, and obtained by next equation.

$$S_c = \frac{Et}{3.125D} \quad (25)$$

E : Modulus of longitudinal elasticity at design temperature of material(N/mm²)

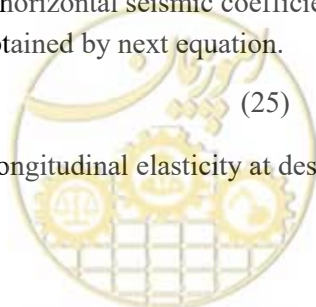

t : Side plate board thickness at position in which stress is calculated(mm)

D : Side plate internal diameter(mm)

σ_{t0} : Average axial tensile stress by internal pressure and obtained by next equation. (N/mm²)

$$\sigma_{t0} = \frac{P_0 D}{4t} \quad (26)$$

σ_{c0} : Average axial compression stress by self-weight position in which stress is calculated and obtained by next equation (N/mm²)

$$\sigma_{c0} = \frac{(W_r + W_s)}{\pi D t} \quad (27)$$

Here, W_r : Full load of roof part(N)

W_s : Weight of side plate that acts on position in which stress is calculated(N)

σ_{cE} : Axial compressive stress at position in which stress when design modification horizontal seismic coefficient K_{MH} and design modification perpendicular seismic intensity K_{MV} act is calculated, and obtained by next equation.(N/mm²)

$$\sigma_{cE2} = K_{MH2} \frac{4(1-h/H_1)^{1.3} W_2 H_2}{\pi D^2 t} \quad (28)$$

2-2-2- Allowable ductility factor

Allowable ductility factor related to buckling of side plate by type-1 design earthquake motion

For, $\sigma_0/S_c \leq 0.2$,

$$\mu_{pa} = 0.35$$

For, $0.2 < \sigma_0/S_c$

$$\mu_{pa} = 0.13$$

Here

μ_{pa} : Allowable ductility factor

σ_0 : Average axial compression stress, and obtained by next equation (N/mm²)

$$\sigma_0 = \frac{(W_r + W_s)(1 + K_{MV}) - P_0 \pi R^2}{2\pi R t}$$

S_c , W_r , W_s , P_0 , t : Provided in 2-3-1

R : Radius of side plate (mm)



Appendix 3

3-1-Flowchart of allowable span in seismic design of piping

When importance factor of structure is intermediate or low, allowable span method is used and if importance factor is very high or high, allowable stress must be used.

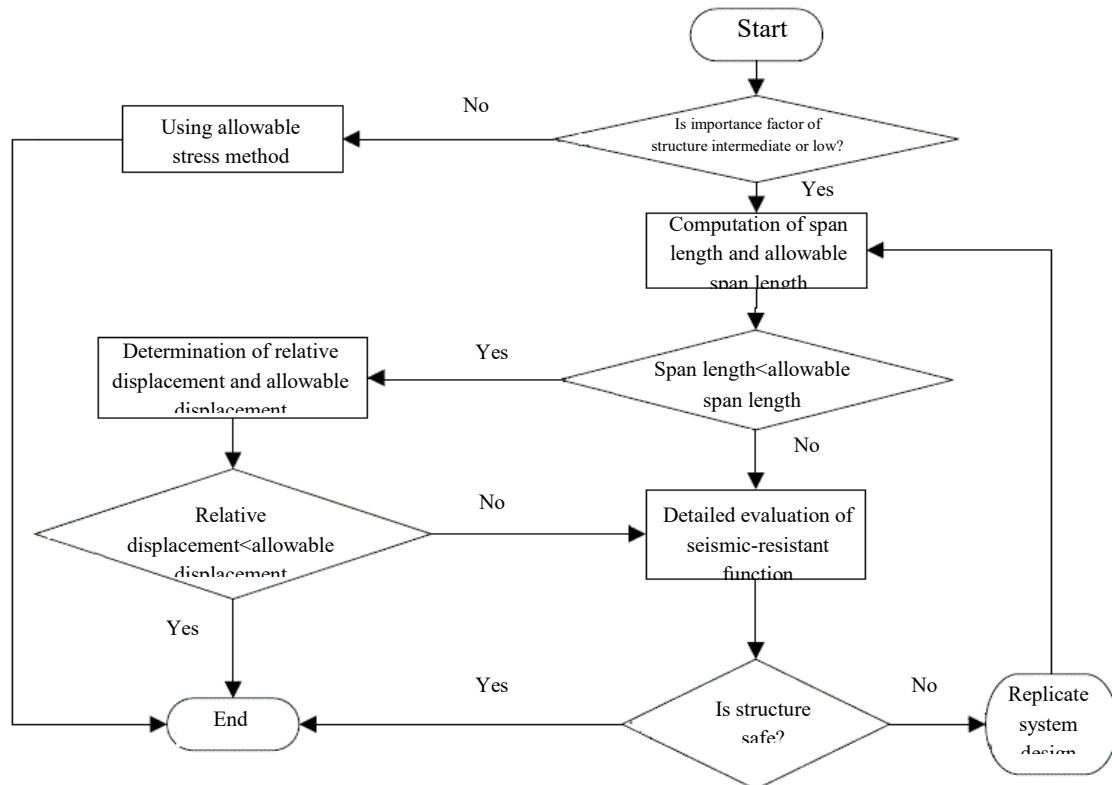

Figure 3-Flowchart of allowable span

3-1-1-Method of span length calculation

Pipe span length is computed with following general methods:

- 1-Each pipe span is evaluated in two horizontal directions and one vertical direction of earthquake
- 2-For evaluation in a direction, pipe span length between two support points is equal to sum of pipe projections between those two support points in the direction perpendicular to earthquake.
- 3-in section 2, if pipe axis direction is in the main direction of earthquake, calculations don't be done in other direction.



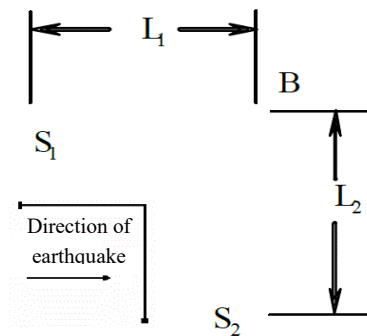

Figure 4-pipe span with support point in the direction of pipe axis

In the example of figure 2, S_1 and S_2 are support points. Since pipe axis of S_1 - B is coordinated with direction of earthquake so it is not required to L_1 be added to length of pipe span, so $L_{PS} = L_2$.

4-In the case that external diameter of pipe is various in the pipe span, span length of L is computed using equation (1) and converted into maximum diameter of pipe span.

$$L = l_p + l_1 \sqrt{\frac{d}{d_1}} \quad (32)$$

Where

- L length of pipe span (m)
- d maximum external diameter of pipe span (mm)
- d_1 external diameter of pipe (mm)
- l_p length of pipe with external diameter of d (m)
- l_1 length of pipe with external diameter of d_1 (m)

5-In the case that the pipe has more than one junction:

Allowable span length between two supports must be obtained. For figure (3) $(L_1 + L_2)$, $(L_1 + L_b)$ and $(L_2 + L_b)$ must be less than allowable span length. In this figure, if the junction diameter is less than half of main pipe diameter, main pipe length must be less than allowable span length.

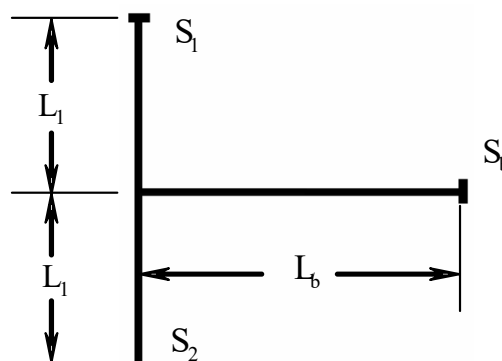

Figure 5-Span of pipe involving junction



3-1-2-Calculation of allowable span length

Table 1 presents basic allowable span length. If external diameter is not available in the table, it can be derived by interpolation. If external diameter is less than 48.6 mm, equal to 48.6 mm or more than 609.6 mm, it is considered to be 609.6 mm. But it is not applicable if external diameter is more than 1000 mm.

Table 16-Allowable span length of pipe

| Standard concentrated weight (compressed gas) W_a (N) | Standard concentrated weight (liquid gas) W_a (N) | basic allowable span length (compressed gas) L_a (m) | basic allowable span length (liquid gas) L_a (m) | External diameter (mm) |
|--|--|---|---|------------------------|
| 304 | 407 | 7 | 6.6 | 48.6 |
| 445 | 605 | 7.8 | 7.1 | 60.5 |
| 839 | 1116 | 8.7 | 7.9 | 76.3 |
| 1126 | 1545 | 9.5 | 8.6 | 89.1 |
| 1414 | 1986 | 10.1 | 9 | 101.6 |
| 1775 | 2532 | 10.7 | 9.5 | 114.3 |
| 2616 | 3802 | 11.7 | 10.2 | 139.8 |
| 3616 | 5357 | 12.7 | 10.8 | 165.2 |
| 6349 | 9629 | 14.8 | 12.2 | 216.3 |
| 9863 | 15208 | 16.4 | 13.2 | 267.4 |
| 14281 | 22361 | 18 | 14.2 | 318.5 |
| 18110 | 28851 | 19 | 15 | 355.6 |
| 25339 | 40325 | 20.3 | 16 | 406.4 |
| 33995 | 53612 | 21.5 | 16.8 | 457.2 |
| 42112 | 67633 | 22.7 | 17.8 | 508 |
| 51141 | 83563 | 23.8 | 18.4 | 558.8 |
| 64243 | 103946 | 24.9 | 19.1 | 609.6 |

In the case that broad weight of heat-insulant material or concentrated weight of valve is added, allowable span length is computed from multiplication of basic allowable span length, presented in tables 1 and 2, in broad weight correction factor ϕ_d and concentrated weight correction factor ϕ_c .

1-when the broad weight of heat-insulant material is added, broad weight correction factor ϕ_d is computed from formula (2):

$$\phi_d = \left(1 + \frac{\Gamma}{\Gamma_p} \right)^{-0.25} \quad (33)$$

ϕ_d broad weight correction factor, when $\phi_d = 1.0$, $\Gamma/\Gamma_p \leq 0.5$

Γ_p Sum of longitudinal weight of pipe and content weight in each meter (N/m)

Γ Broad weight of heat-insulant material in one meter of pipe length (N/m)

2-when the concentrated weight of valves is added, concentrated weight correction factor ϕ_c is computed based on table 3. Overweight rate γ_w is computed from formula (34)

$$\gamma_w = \frac{W_s}{W_a} \left(1 + \frac{\Gamma}{\Gamma_p} \right)^{\frac{3}{4}} \quad (34)$$

γ_w overweight rate

W_s concentrated weight of span (N)

W_a standard concentrated weight (N) for liquid and concentrated gas piping indicated in table

(16)

Table 16-concentrated weight correction factor

| Overweight rate limit γ_w | Concentrated weight correction limit ϕ_c |
|-------------------------------------|--|
| $\gamma_w \leq 0.25$ | $\phi_c = 1$ |
| $0.25 < \gamma_w \leq 1$ | $\phi_c = 1.13 - 0.53\gamma_w$ |
| $1 < \gamma_w$ | $\phi_c = 0.636 - 0.036\gamma_w$ |

1-3-Calculation of piping displacement capacity

1-Piping displacement capacity

Piping span displacement capacity is computed from equation (35). Support displacement must be less than allowable displacement capacity (Δ)

$$\delta_a = L_{PS} \cdot f_p \quad (35)$$

Where

L_{PS} : allowable span length (mm)

δ_a : piping displacement capacity in the direction of earthquake (mm)

f_p : displacement capacity of piping length in each millimeter that its value obtained from equation

(5)

$$f_p = C \cdot \varepsilon_y \cdot L_{PS} / d \quad (36)$$

C displacement constant of allowable piping span that is equal to 0.67

d maximum external diameter of pipe span (mm)

ε_y least value of yield strain dor design temperature and normal temperature of piping material which

2-Capacity of expansion connection displacement

Capacity of pipe span displacement with corresponding expansion connection with mentioned allowable strain in expansion connection specifications.

3-For figure 3, control is as following:

3-1-when external diameter of junction is more than half of main pipe diameter.

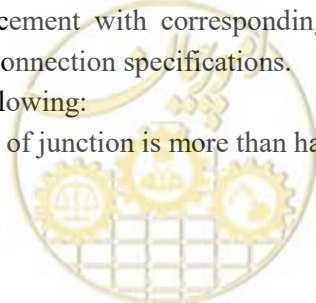

Displacement capacity of Figure length $L_j(12) = (L_1 + L_2)$, $L_j(1b) = (L_1 + L_b)$ and $L_j(2b) = (L_2 + L_b)$ is assumed $\delta_a(12)$, $\delta_a(1b)$ and $\delta_a(2b)$ respectively and relative displacement of support point $S_1 - S_2$, $S_1 - S_b$ and $S_2 - S_b$ is assumed $\Delta(12)$, $\Delta(1b)$ and $\Delta(2b)$ respectively. Then evaluation of displacement capacity is performed through confirmation of $\Delta(12) \leq \delta_a(12)$, $\Delta(1b) \leq \delta_a(1b)$ and $\Delta(2b) \leq \delta_a(2b)$. It is assumed in this figure that earthquake direction must be perpendicular to paper direction and S_1 , S_2 and S_3 are support points which halter the direction perpendicular to paper.

3-2-When external diameter of junction is equal or less than the half of main pipe diameter. Evaluation of displacement capacity is performed through confirmation of following equations.

$$\frac{\Delta(1b) + \Delta(2b)}{2} + 20 \left(\frac{L_{12}}{L_{PS}} \right) \leq \delta_a(T_b) , \Delta(12) \leq \delta_a \quad (37)$$

It is assumed that $\delta_a(T_b)$ is displacement capacity of L_{PS} , L_{PS} is allowable span and L_{12} is the length of pipe span.

1-4-Calculation of relative displacement

1-Relative displacement

For evaluation of capacity of pipe span displacement, it is assumed that displacement in the direction of earthquake is equal to the displacement of pipe support structure that is obtained by following method based on height of support point.

Relative displacement of piping span Δ is obtained from equation (38).

$$\Delta = \delta_1 + \delta_2 \quad (38)$$

Δ relative displacement of piping span

δ_1 displacement of support point 1 in earthquake (mm)

δ_2 displacement of support point 2 in earthquake (mm)

2- Calculation steps of displacement piping support structure in earthquake

Calculation steps are given in figure 4



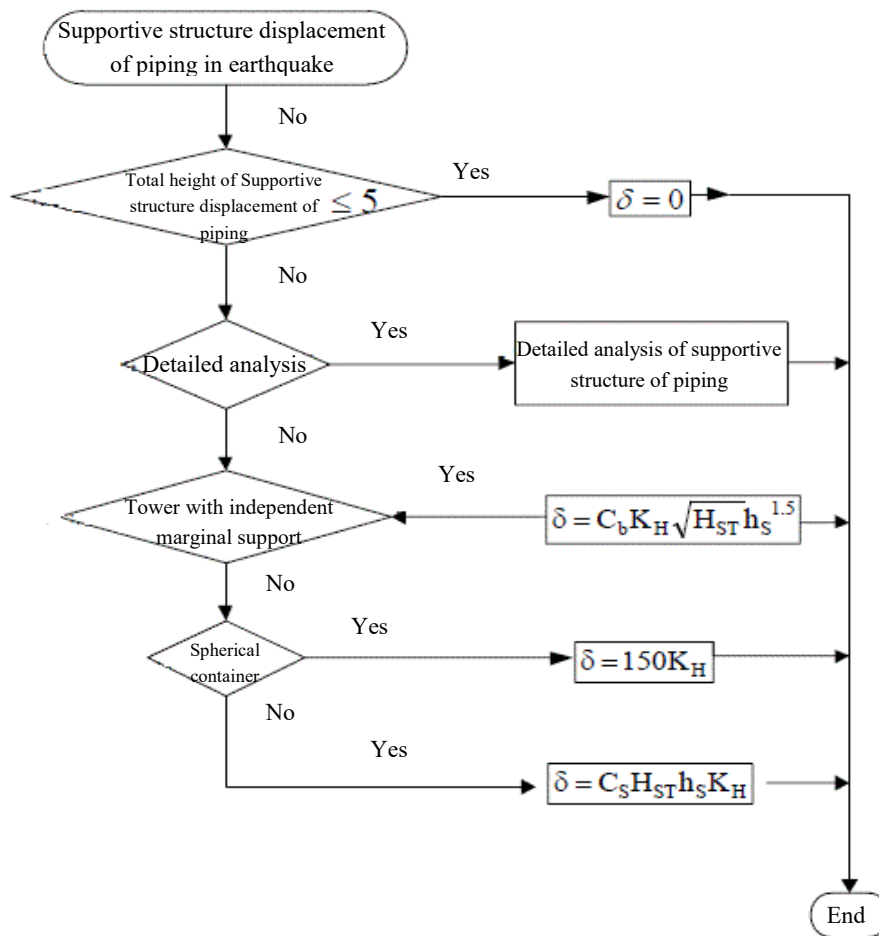

Figure 6-calculation steps of support structure displacement of piping in earthquake

As indicated in the displacement evaluation, if support structure of piping is equal or less than 5m, that evaluation can be neglected.

1-Support displacement of tower piping with independent marginal support in any height in earthquake can be computed in terms of millimeter through equation (39).

$$\delta = C_b K_H \sqrt{H_{st}} \cdot h_s^{1.5} \tag{39}$$

Where

K_H Horizontal intensity of earthquake in ground level with consideration of importance level of piping system

C_b 1

H_{st} Total height of support structure of piping (m)

h_s Height of support point of piping (m)

2-Spherical container displacement in earthquake is computed using equation (40)

$$\delta = 150 K_H \tag{40}$$

Where



K_H Horizontal seismic intensity in the ground level with consideration of importance level of piping system.

3-support displacement of piping of other support structures in earthquake in any height is given by equation (11):

$$\delta = C_S \cdot K_H H_{st} \cdot h_s \quad (41)$$

Where

K_H Horizontal seismic intensity in the ground level related to importance level of piping system.

C_S 0.7

3-2-Standard structure of seismic design of piping system



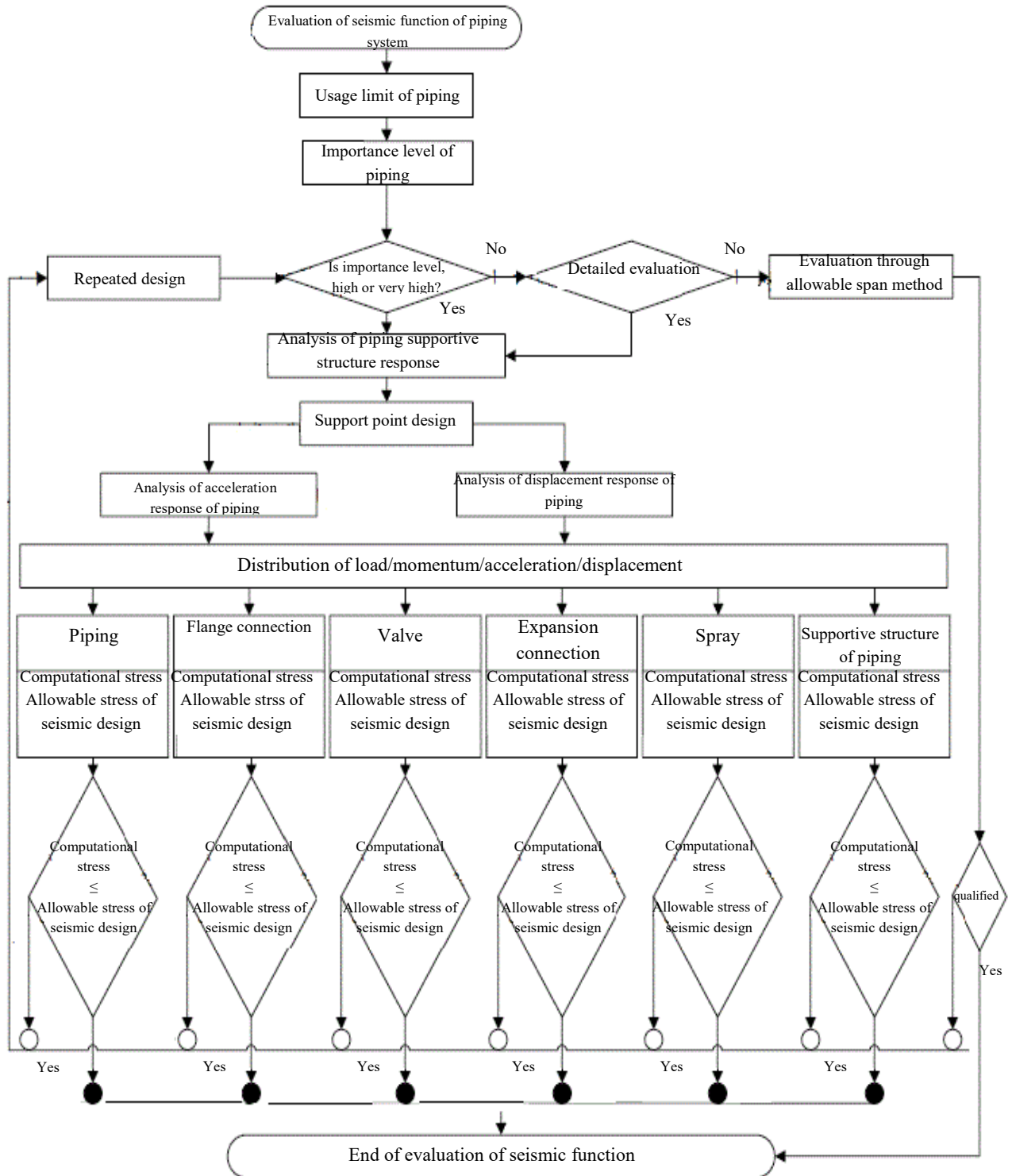

Figure 7-Standard structure of seismic design for piping system



3-3-Analysis of structure response for piping support

Figure 6 shows the analysis of structure response for piping support

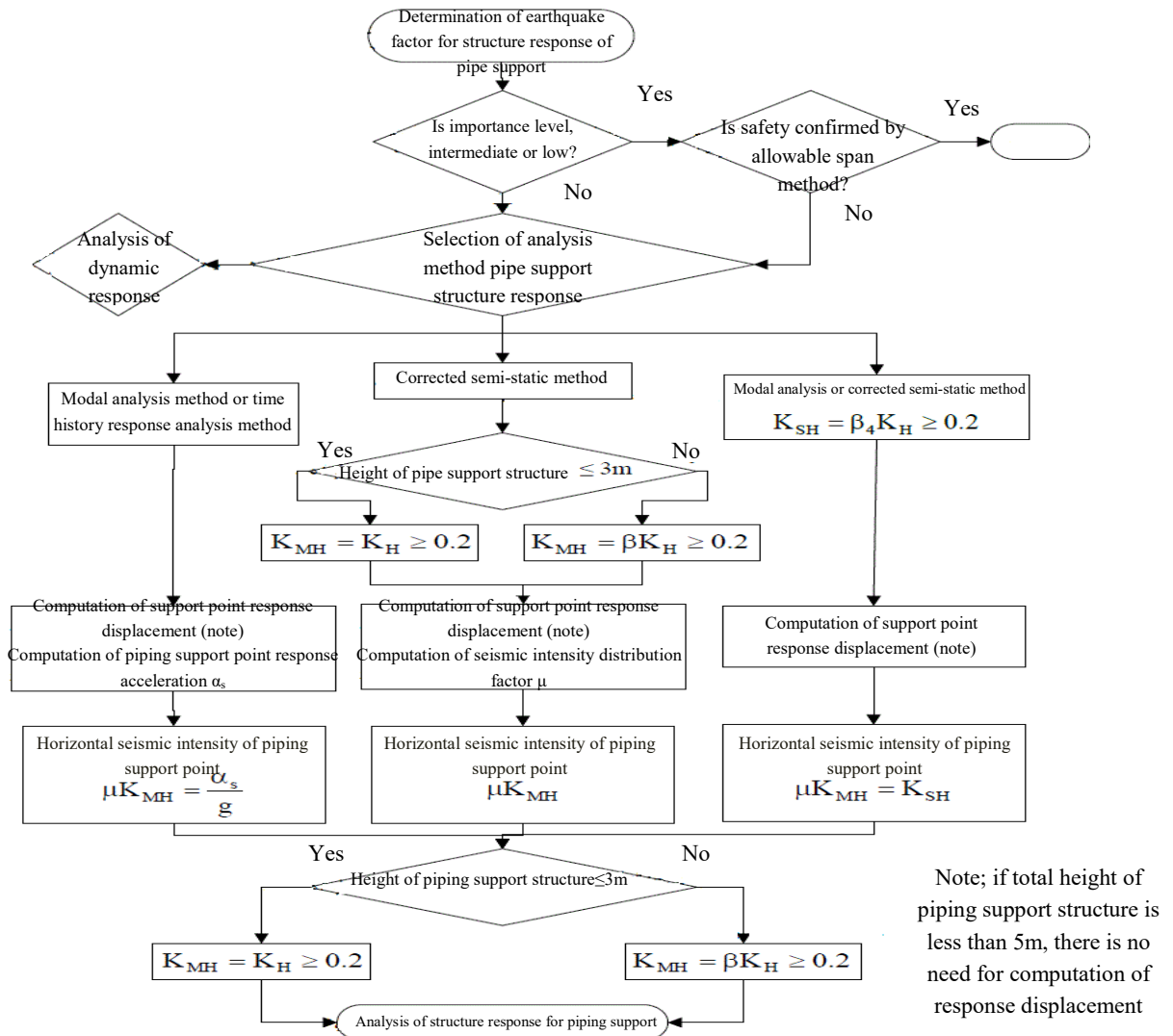

Figure 8-Steps of designing piping support structure response

1-Importance level of piping support structure

In analysis of piping support structure response, importance level is computed on the basis of importance level of related piping, acceleration and displacement of response in the piping support point. Evaluation of seismic function is performed according to maximum importance level among importance level of equipment and piping related to piping support structure.

2-Amplification factor of horizontal response through semi-static method

Table 4 presents amplification factor of horizontal response β_4 of piping support structure designed through semi-static method based on height H from the ground level.



Table 17-Amplification factor of horizontal response β_4

| H(m) | β_4 |
|------------------|----------------|
| $H(m) \leq 16$ | 2.0 |
| $16 < H(m) < 35$ | $1.04 + 0.06H$ |
| $H(m) \geq 35$ | 3.14 |

3-Amplification factor of horizontal response through semi-corrected method

Amplification factor of horizontal response of piping support structure designed through semi-corrected method is obtained from multiplication of amplification factor of standard response in correction factor. Amplification factor of standard response is based on the natural period and type of ground in the location of piping support structure and correction factor on the basis of decay factor of piping support structure¹.

4-Amplification factor of vertical response

Amplification factor of vertical response in the tower with independent marginal support is to be 1.5 and in other piping support structures is to be 2.

5-Distribution factor of seismic intensity

When analysis of piping support structure response is performed via corrected-semi static method, distribution factor of seismic intensity μ is computed on the basis of type and height of piping support structure, as is shown in the figure 7.

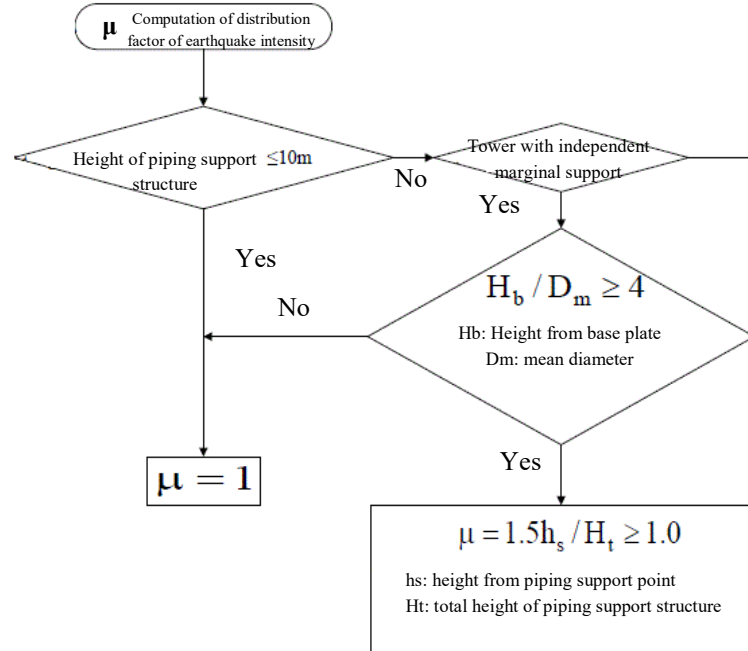

For support piping in spherical container shell, because all of the shell is displaced.
 hs: height of shell center (mm)
 Ht: height of upper crest of spherical shell (mm)
 When $\mu < 1.0$, then $\mu = 1$

1 - these are given in the guideline for loading and seismic analysis of lifelines



Figure 9-seismic intensity distribution in the case that piping support structure is analysed via corrected earthquake factor method

3-4-Analytical model and corrected seismic force for designing piping system

Analytical model of piping system for response analyse of acceleration and displacement is developed according to following rules:

- 1- Analytical model of piping support structure is developed on the basis of evolution step of seismic function of towers, containers and framed structures.
- 2- In analytical model of piping, direct pipe is considered as beam element and curved pipe is considered as curved beam element.
- 3- In total, analytical modeling of piping is performed between fixed points. However, from mechanical point of view, modeling is not confined to these points.
- 4- Solidity of piping beam element is computed by reduction of allowable value of corrosion from nominal dimensions.
- 5- Allowable value of corrosion is considered for calculation of weight.
- 6- Allowable value of corrosion is considered for calculation of piping tension.

3-5-calculation of piping stress

1-load composition

Piping load compositions in table (5) is used for evolution of seismic function.

Table 5-load composition in seismic designing of piping

| Load type | Earthquake force | | Stimulant weight | Fluid pressure |
|--------------|---------------------------|---------------|------------------|----------------|
| | Relative displacement | Inertia force | | |
| Tension type | | ○ | ○ | ○ |
| | ○ Supportive structure | ○ | | |

2-flexibility factor and stress intensification factor

Flexibility factor and stress intensification factor for calculation of longitudinal stress of piping and alternative stress are obtained from table (6). However, if data be available, modeling is not confined to these points.

3-combination of stresses of earthquake in different direction

In evaluation of commutative stress, the most unfavorable direction of earthquake is used. If determination of this direction is difficult, two horizontal directions are applied independently. For combination of horizontal and vertical direction of earthquake, stress in two horizontal directions and two vertical directions are computed and momentum and axial force are obtained from sum of absolute value.

4-relative displacement

When reliance points of piping are located in various supports, relative displacement values between various reliance points must be computed for vibration in different directions.

5-External force for evaluation of flange and spray of equipment

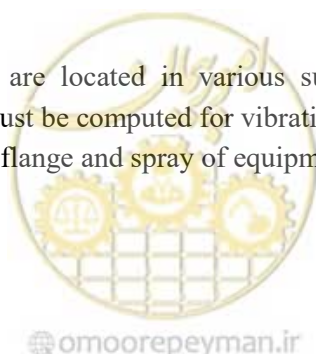

Sum of absolute value of axial force and momentum of above-explained components of external force are considered in evaluation of flange and spray of equipment

6-Specifications of stress calculation

Longitudinal elastic module in operational temperature is used for calculation of stress. Value of elastic module has been given in the clause of 3-4 in the text. Suitable value of the Poisson ratio is 0.3.

7-Seismic intensity distribution in piping height

In the case of changing horizontally corrected seismic intensity in reliance point of piping in height, linear distribution is convenient.

Nearly mean horizontally corrected seismic intensity is considered in design of two reliance points. If its distribution is biased on one direction, seismic intensity distribution requires more accuracy.

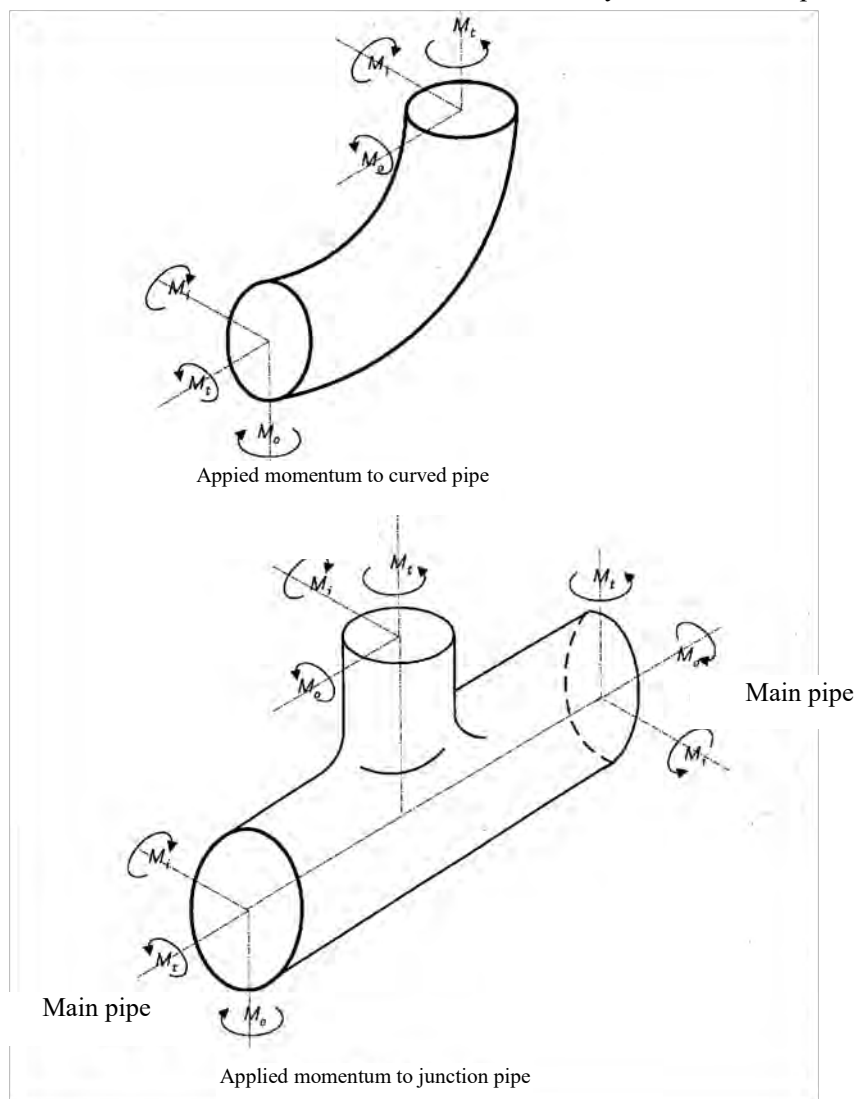
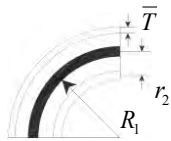
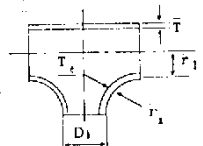
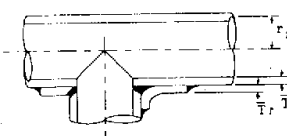
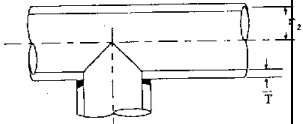
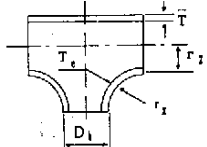
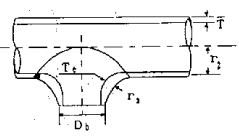
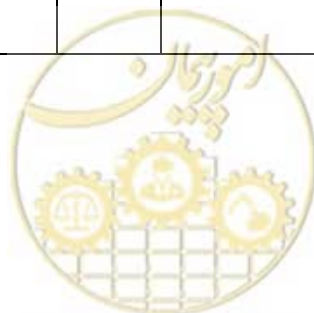

Figure 10-Definition of momentum



Table 19-Flexibility factor and factor of stress intensification

| Connection type | flexibility factor k | factor of stress intensification (3)(2) | | Characteristic value of flexibility | Simplified design |
|---|------------------------|---|------------------------|---|---|
| | | Inter-planar i_i | Extra-planar i_o | | |
| Welded elbow or bending (2) (4) (5) (6)(7) of pipe | $\frac{1.65}{h}$ | $\frac{0.9}{h^{2/3}}$ | $\frac{0.75}{h^{2/3}}$ | $\frac{\bar{T}R_1}{r_2^2}$ |  |
| ASMEB16 and 9. Welded T shape of pipe $r_x \geq 1/8D_b$ $T_e \geq 1.5\bar{T}$ (2)(4) (6)(11)(13) | 1 | $\frac{3}{4}i_o + \frac{1}{4}$ | $\frac{0.9}{h^{2/3}}$ | $3.1 \frac{\bar{T}}{r_2}$ |  |
| Reinforced shape with T pipe, sheet or saddle (2)(4) (8)(12)(13) | 1 | $\frac{3}{4}i_o + \frac{1}{4}$ | $\frac{0.9}{h^{2/3}}$ | $\frac{(\bar{T} + 1/2\bar{T}_r)^{2.5}}{\bar{T}^{1.5}r_2}$ |  |
| Non-reinforced T-shape of pipe (2)(4) (12)(13) | 1 | $\frac{3}{4}i_o + \frac{1}{4}$ | $\frac{0.9}{h^{2/3}}$ | $\frac{\bar{T}}{r_2}$ |  |
| Welded t-shape of exit pipe $r_x \geq 0.05D_b$ $T_e < 1.5\bar{T}$ (2)(4) (13) | 1 | $\frac{3}{4}i_o + \frac{1}{4}$ | $\frac{0.9}{h^{2/3}}$ | $\left(1 + \frac{r_x}{r_2}\right) \frac{\bar{T}}{r_2}$ |  |
| Junction welded connection $r_x \geq 1/8D_b$ $T_e \geq 1.5T$ (2)(4) (11)(13) | 1 | $\frac{3}{4}i_o + \frac{1}{4}$ | $\frac{0.9}{h^{2/3}}$ | $3.1 \frac{\bar{T}}{r_2}$ |  |

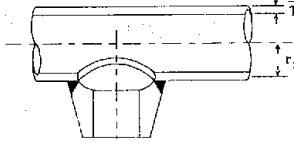

| | | | | | |
|--|---|-----------------------|-----------------------|---------------------------|---|
| Welded junction connection (reinforced integrated type) (2)(4) (9)(12) | 1 | $\frac{0.9}{h^{2/3}}$ | $\frac{0.9}{h^{2/3}}$ | $3.3 \frac{\bar{T}}{r_2}$ |  |
|--|---|-----------------------|-----------------------|---------------------------|---|

Values in the parenthesis points to these notes:



Table 20- Flexibility factor and factor of stress intensification

| Connection type | factor of stress intensification i | Flexibility factor k |
|---|--------------------------------------|------------------------|
| Lip to lip welding connection type, reducer or end flange of pipe or Lip to lip welding connection type | 1.0 | 1 |
| Pipe flange or two sided weld | 1.2 | 1 |
| Connection or angle weld or pipe or ended flange or bean welding | Note 14 | 1 |
| Overall flange or connection (JPI-7S-15 or ASMEB16.9 stub end) | 1.6 | 1 |
| Torsion connection or pipe or flange | 2.3 | 1 |
| Undulated direct pipe or curve, note 10 | 2.5 | 5 |

Note:

1-When there is not available data, tables 6 and 7 are used. This table is valid for $D/T \geq 100$

2- Flexibility factor k , mentioned in these tables is used for elbow. Flexibility factor k and factor of stress intensification i is considered equal or more than 1 and in the case of bolt, considered to be equal to 1. Both factors are applied in the bending of the pipe for effective length of curvature (indicated as more bolded line in the figure) and in the T-shaped pipe are applied in the intersection point.

3-For both factors of i_i and i_0 , relation $\frac{0.9}{h^{2/3}}$ can be used conservatively.

4- Curvature characteristic value of h is computed for before-mentioned relation and values of k and i can be obtained directly, where:

- \bar{T} for elbow, nominal thickness of pipe connection and for T-shaped pipe, nominal thickness of installed pipe (mm)
- T_e angle section thickness of T-shaped pipe (mm)
- \bar{T}_r plate or saddle thickness (mm)
- r_2 mean radius of installed pipe (mm)
- R_1 curvature radius of welded elbow of pipe bending (mm)
- R_x curvature radius on the surface exterior from junction limit on the face that include mother pipe axis and extruded pipe (mm)
- D_b external diameter of extruded pipe (mm)

5-when flange is installed in part of the pipe or in the two ends of it, characteristic value of curvature h is computed and factor value of C_1 is obtained directly (using figure 9) and values of i and h of the table are corrected using this factor.

6-Thickness of pipe connection with groove weld is significantly greater than the thickness of installed pipe. If this thickness isn't considered, high amount of error may be occurred.

7-Pressure affects very highly on i and k values of elbow and pipe bending with high diameter and thin wall. Correction of the table values is performed through following relations. In two following relations, E is longitudinal elastic module (MPa).

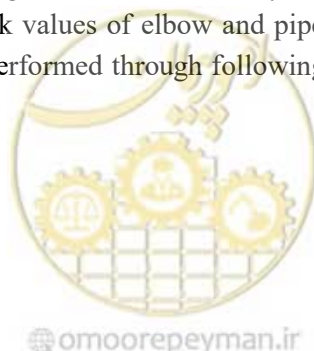

k is divided on $1 + 6 \left(\frac{P}{E} \right) \left(\frac{r_2}{\bar{T}} \right)^{7/3} \left(\frac{R_1}{r_2} \right)^{1/3}$.

i is divided on $1 + 3.25 \left(\frac{P}{E} \right) \left(\frac{r_2}{\bar{T}} \right)^{5/2} \left(\frac{R_1}{r_2} \right)^{2/3}$.

8-For $\bar{T}_r > 1.5\bar{T}$, h value is equal to $h = 4\bar{T}/r_2$

9-a pressure equal to pressure applied on direct pipe is applied on this connection.

10-Both factors are used for bent. Flexibility factor of bolt is assumed to be equal to 0.9.

11-When there is not sufficient data and bent is not in the suitable limit of diameter and thickness, Characteristic value of bent h is equal to \bar{T}/r_2 .

12-For junction connection with various diameters, where ratio of external diameter of junction pipe to main pipe is in the limit $0.5 < d/D < 1.0$, extra-planar stress intensification factor (SIF) that can be extracted from figure 9, may not be convenient. That indicates that glossy welding reduces SIF, so suitable SIF must be chosen.

13-In stress intensification factor, it is assumed that minimum diameter of the body is twice the diameter of main pipe. It is required that certain considerations must be adopted for input narrow pipe.

14-Maximum up to 2.1 or less value of $2.1\bar{T}/C_x$ is considered but this value must be higher than 1.3. Here, C_x indicate welding base of angle. Lower values are assumed for base length.



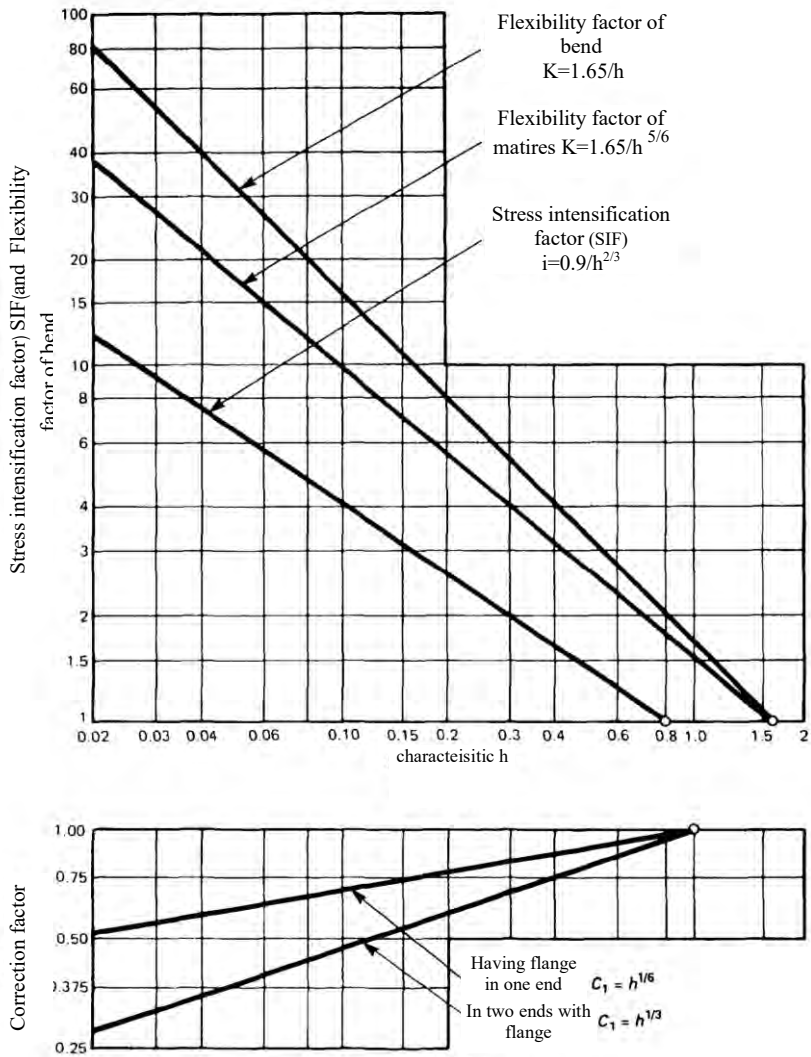

Figure 9-flexibility factor and stress intensification factor (SIF)



3-6-Allowable stress of piping seismic design

Table (8) presents allowable stress of piping seismic design based on stress type.

Table 21- allowable stress of piping seismic design

| Stress type | Allowable stress of seismic design |
|--------------------------|------------------------------------|
| Longitudinal stress | S |
| Alternative stress limit | $2S_y$ |

S allowable stress for seismic design of compressive material (N/mm^2)

S_y yield strength or yield equivalent strength using 0.2% strain of material

Table 22- allowable stress of piping seismic design based on material type

| Material type | S |
|--|--|
| A)material of aluminum alloy and steel material with 9% Nickel for low temperature lower than room temperature | $S = \min \{0.6S_u, 0.9S_y\}$ |
| B) Austenitic stainless steel material and steel material with high alloy of Nickel, used in temperatures higher than room temperature | $S = \min \{0.6S_{u0}, 0.6S_u, 0.9S_{y0}, S_y\}$ |
| C)material beyond that of a) and b) | $S = \min \{0.6S_{u0}, 0.6S_u, 0.9S_{y0}, S_y\}$ |

Where

S_u and S_{u0} Tensile strength in design temperature and normal temperature material which its value is four times of allowable tensile stress

S_y and S_{y0} yield strength or yield equivalent strength using 0.2% strain of material

3-7-Step of seismic function evaluation of flange connection

1-Steps of seismic function evaluation

Figure 10 shows Step of seismic function evaluation of flange connection.

2-Allowable stress of seismic design

Allowable stress of seismic design is determined based on stress type through table (23).



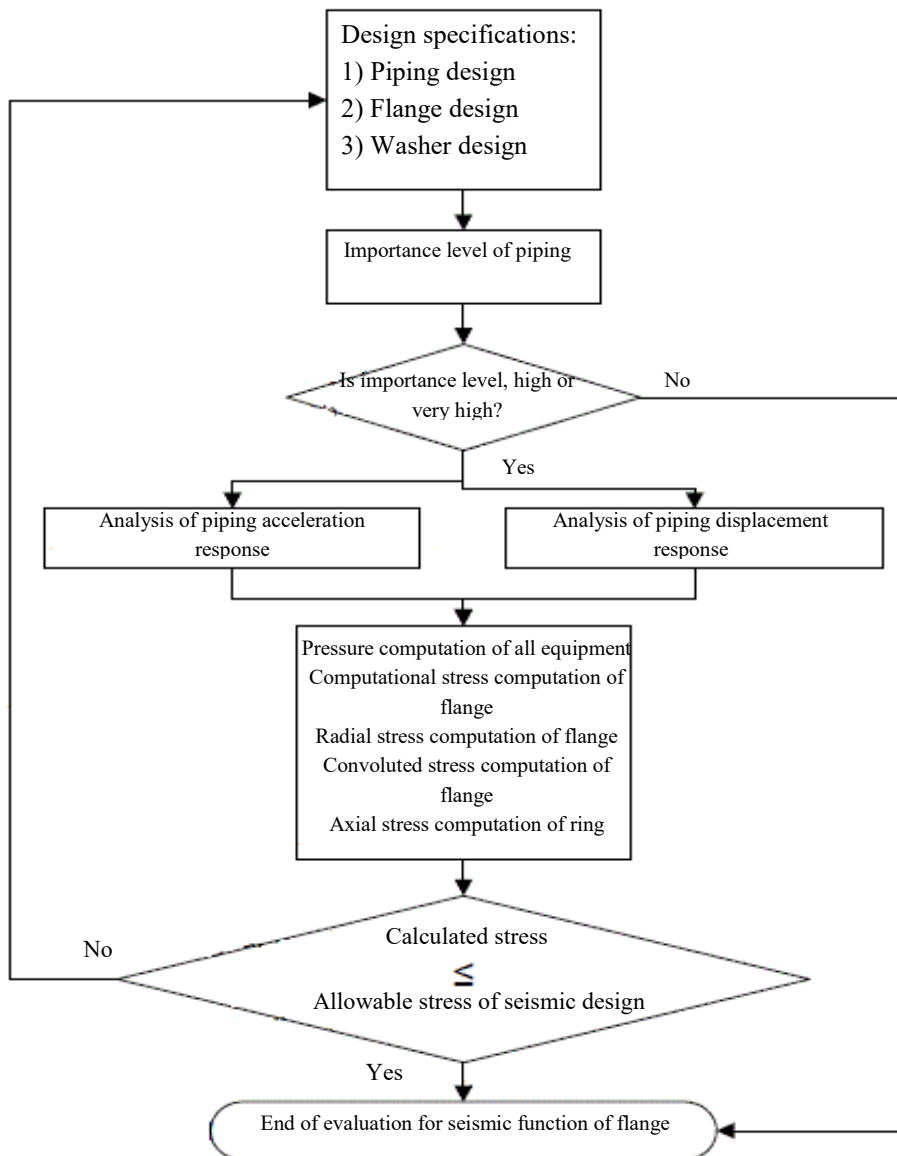

Figure 11-Steps of evaluation for seismic function of flange connection

Table 23-Allowable stress of seismic design of flange connection

| Stress type | Allowable stress of seismic design |
|-----------------------------|------------------------------------|
| Radial stress of flange | S |
| Convoluted stress of flange | S |
| Axial stress of ring | 2S _y |

S and S_y are explained in section 3-4.

3-Stress calculation parameters



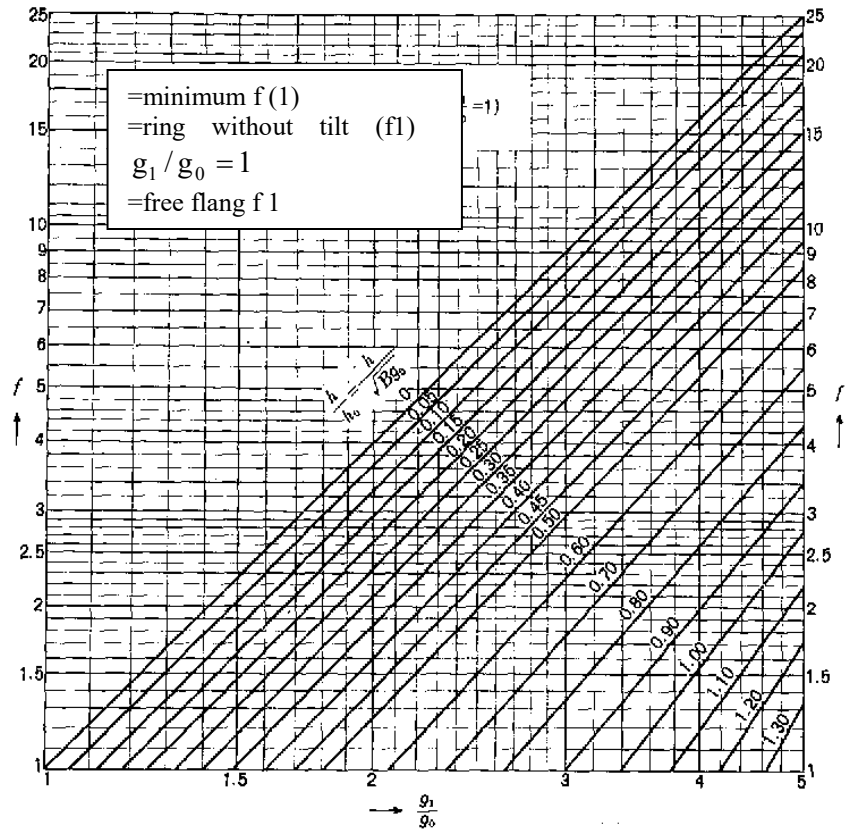

Figure 12-value of parameter f

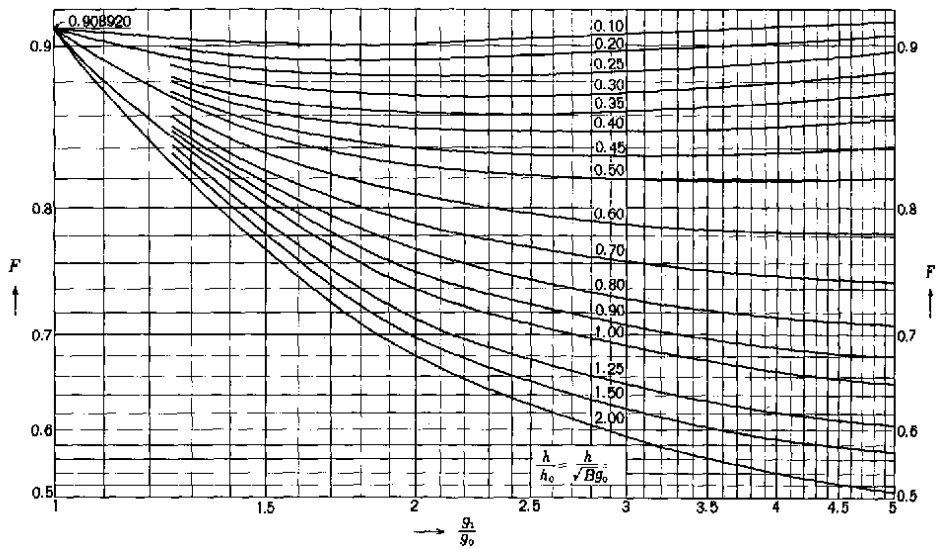

Figure 13-value of parameter F



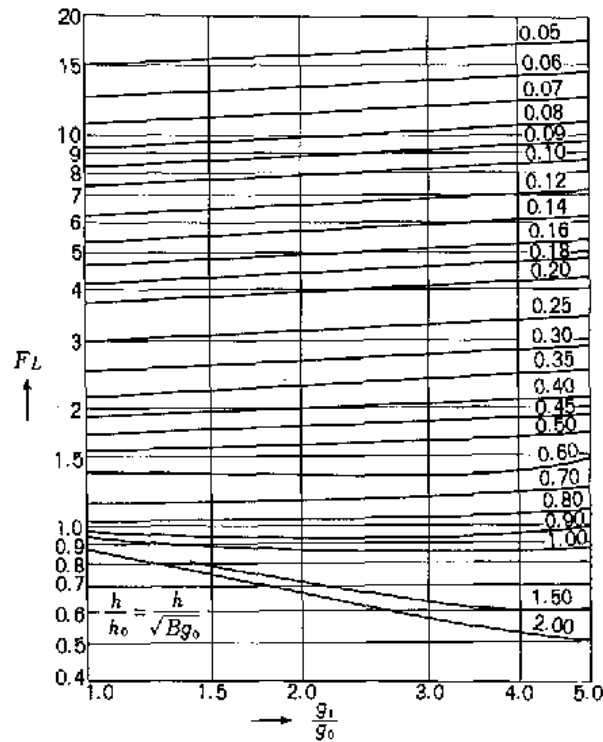

Figure 14-Parameter value of F_L

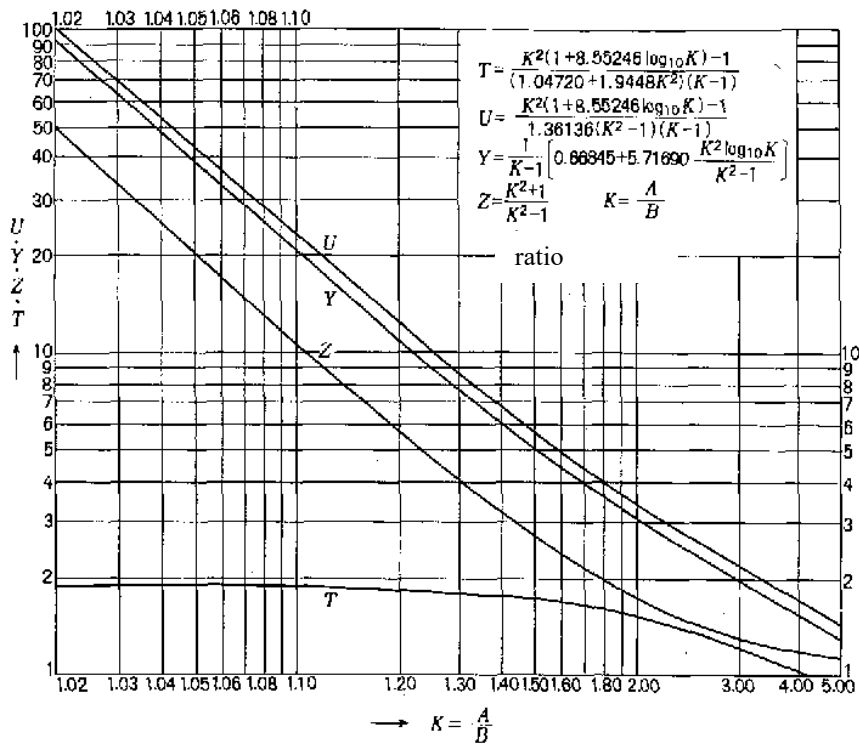

Figure 15-Values of parameters U, Z, Z and T



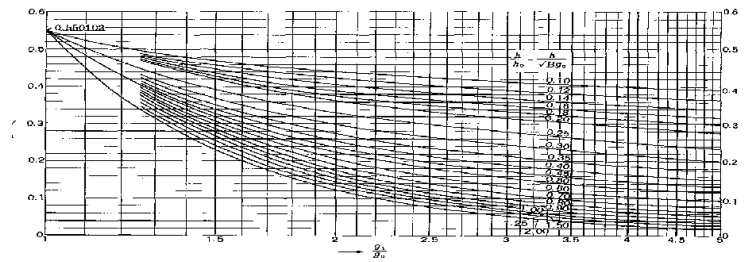
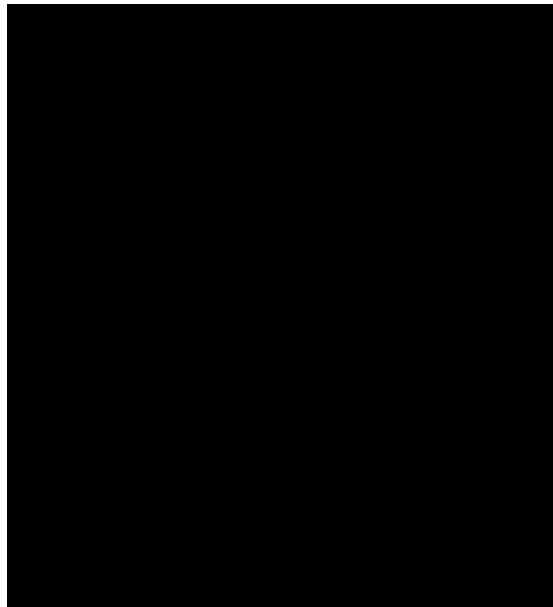

Figure 16-Parameter value of V

Figure 17-Parameter value of V_L

3-8-Seismic evaluation of valve

Because of high natural frequency of common valves such as hand valves, resonance does not occur in them due to earthquake acceleration. In earthquakes with natural frequency, high inertia force is produced in actuator of high weight and relatively far gravity center from piping valve. So seismic function is evaluated by stress calculation in the weakest part between the main body of valve and weighting parts in the outside of the piping center for inertia force resulted from earthquake such as a valve with natural frequency of lower than 20 Hz. In strength is secured, valve cutoff function will be safe.

1-Steps of seismic function evaluation

Figure 17 shows steps of seismic function evaluation.



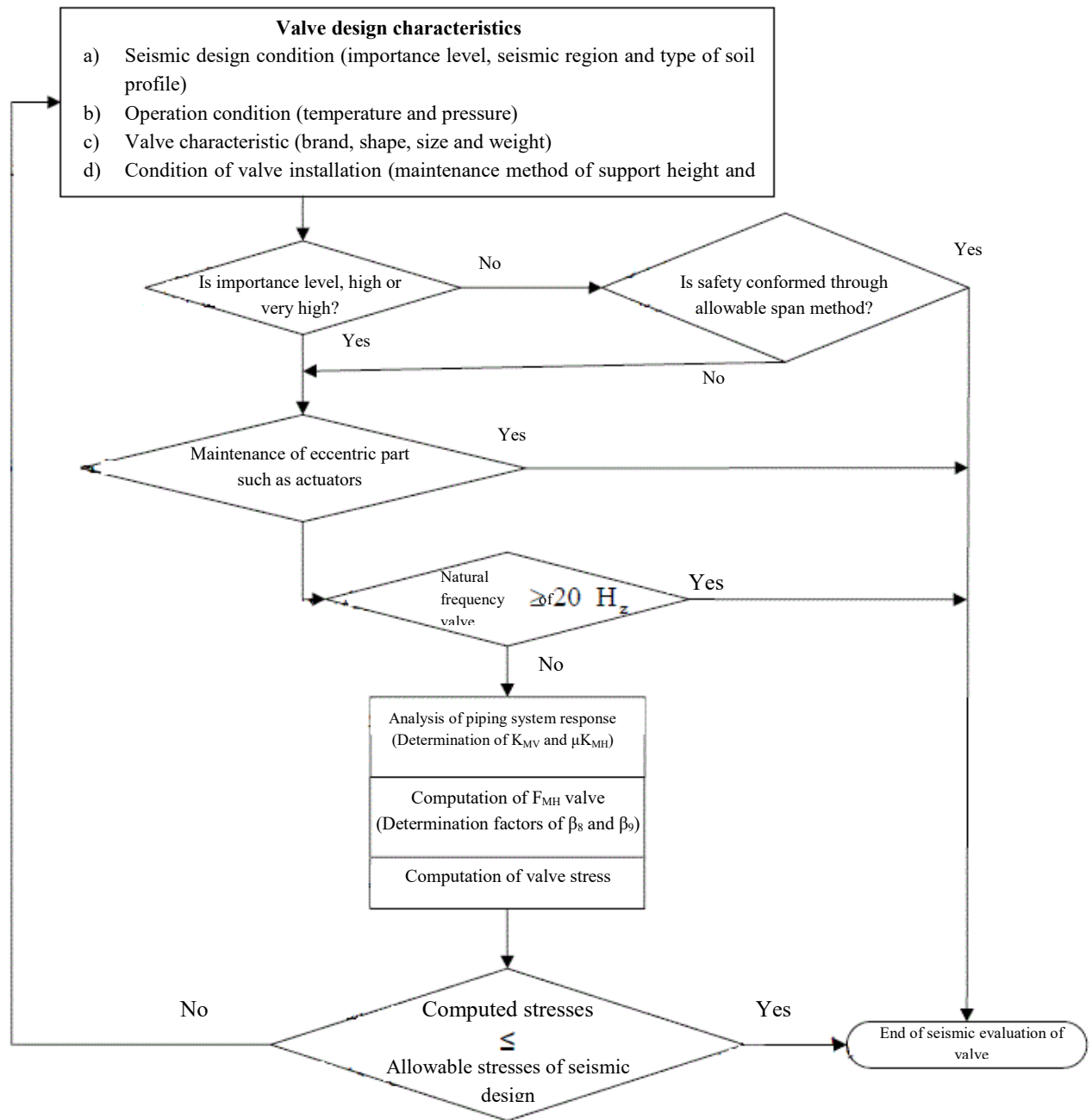

Figure 18-steps of evaluation of valve seismic function

2-Allowable stress of seismic design

Table 11 presents allowable stress of seismic design based on valve type.

Table 24- Allowable stress of valve seismic design

| Valve type | Allowable stress of seismic design |
|-------------------------------------|------------------------------------|
| Closing valve in time of earthquake | 0.5S |
| Other valves | S |

In this table, S is the value that is given in the section 4-3.

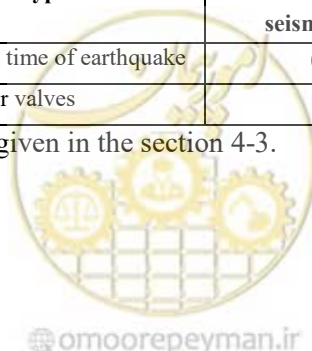

3-9-Method of seismic evaluation for expansion connection

When expansion connection is used for seismic function improvement of piping system, it should be noted that a suitable type of connection is installed in the suitable position and support is in the suitable state. For seismic evaluation for expansion connection, amplitude of maximum axial stress must be lower than total amplitude of allowable stress corresponding to 500 times of numbers of design alternatives.

1-Steps of seismic function evaluation

Figure 18 shows steps of seismic function evaluation for expansion connection

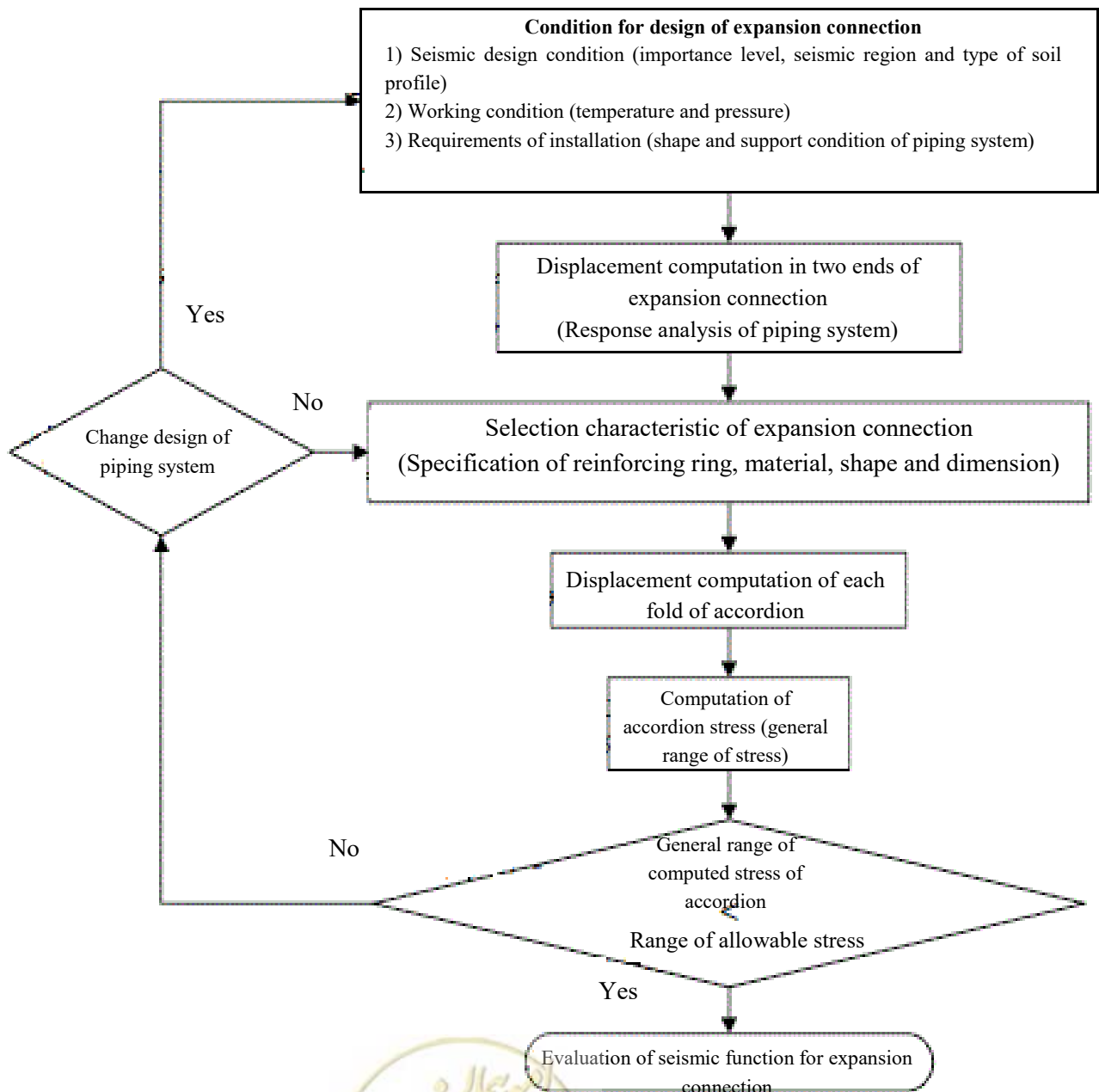
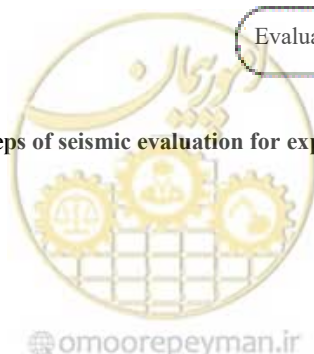

Figure 19- steps of seismic evaluation for expansion connection



2-Allowable stress of seismic design

Allowable stress of seismic design for produced axial stress in expansion connection according is equal to following value, because its value is twice of allowable stress range corresponding to 500 times alternation.

3-Allowable stress of seismic design for produced axial stress in expansion connection folds of solid steel, low alloy steel, ferrite stainless steel and high extensionable steel is as following:

- a) $S_a = 2 \times 724 = 1448 \text{ MPa}$, if least extensional stress is equal or less than 551.6 MPa.
- b) $S_a = 2 \times 724 = 1448 \text{ MPa}$, if least extensional stress is varied between 792.9 and 896.3 MPa .
- c) If least extensional strength is varied between 551.6 and 792.9 MPa, its value is calculated through interpolation method from values of clause a) and b).

4-Allowable stress of seismic design for axial stress of expansion connection according manufactured from stainless steel, nickel alloy (Ni-Cr-Fe alloy and Ni-Ni-Fe alloy) and Cu-Ni alloy is $S_a = 2 \times 1020 = 2040 \text{ MPa}$.

3-10-Method of seismic evaluation of spray in towers and containers

1-Steps of evaluation of spray seismic function

- 1-1-Evaluation of seismic function of spray in towers and containers is done in such a way that primary local stress and difference between minimum value and maximum sum of primary stress and secondary stress must be lower than allowable stress of seismic design respectively.
- 1-2-Stress intensity of spray in towers and containers connected to the piping system with high level of importance is computed according to horizontal seismic force of piping design, vertical seismic force of design and load related to displacement of pipe support point.
- 1-3- Evaluation of seismic function of spray in towers and containers indicated in figure 19 is performed through a simple technique on the basis of the Bairard method. Detailed analysis with finite element method includes similar steps.
- 1-4-Strength investigation of pressurized container is performed through a simple technique (the Bairard method) on the basis of thin shell theory or detailed analysis such as the finite element method (FEM) indicated in the table 12.



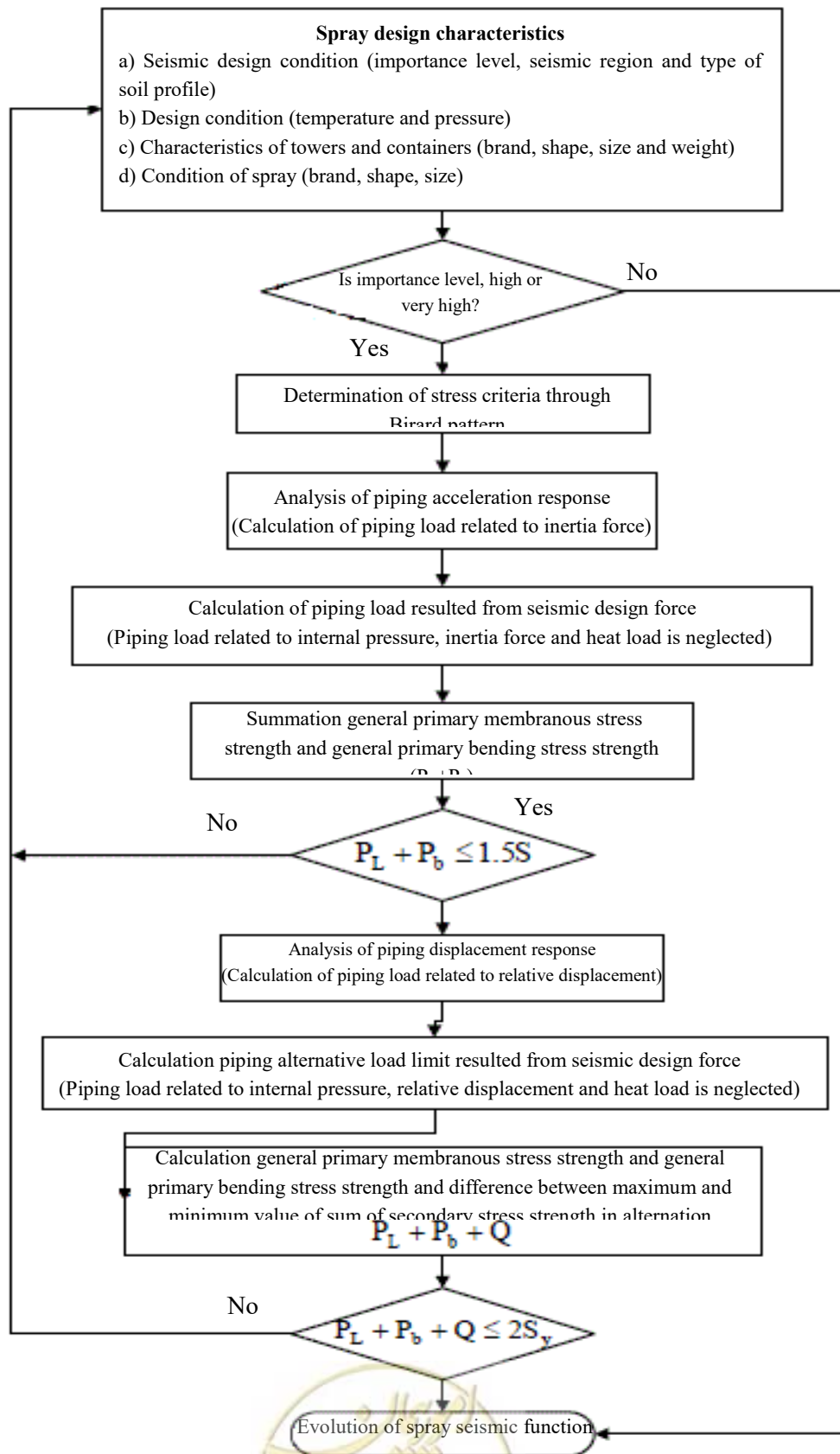

Figure 20-Steps of evaluation of spray seismic function of towers and containers

Table 25-Calculation method of spray of towers and containers

| Spray | Analytical standard and technique |
|--------------------|--|
| Pressure container | (1)- WRC107-1979 (weld research association) "local stresses in cylindrical and spherical shell due to external loading" (according to thin wall shell theory, the Bairard method) (2)- WRC297-1987 "local stresses in cylindrical shells due to external loading on sprays) (a simple technique on the basis of finite element method (FEM)) (3)-Analysis using FEM |

2-Allowable stress intensity for seismic design

Table 26 presents allowable stress intensity for spray seismic design of towers and containers according to stress type.

Table 26-Allowable stress intensity for spray seismic design of towers and containers †

| Allowable stress intensity of seismic design | Type of stress intensity |
|--|---|
| S | general primary membranous stress intensity |
| 1.5S | primary local membranous stress intensity and primary moment-resisting stress intensity |
| 2S _y | primary local membranous stress intensity, primary moment-resisting stress intensity and difference between maximum and minimum sum of secondary stress strength in one cycle |

Where S and S_y indicate value mentioned in section 4-3.

1-Seismic function evaluation of pipe support

Figure 21 shows steps of seismic function evaluation of pipe support that support piping system.

1-1-function of pipe support (support function) is to keeping fix the piping. All earthquake effects is exerted on piping through support and earthquake is exerted to pipe support points. Earthquake effects on piping can be reduced through suitable array of support.

1-2-Piping support drawing

Piping support drawing is prepared for characterization of connection path design to towers and containers. In piping support drawing, piping and support fixing are characterized and displacement allowance and free heat displacement of piping support structure due to earthquake, external force, dead weight and weight load is determined.



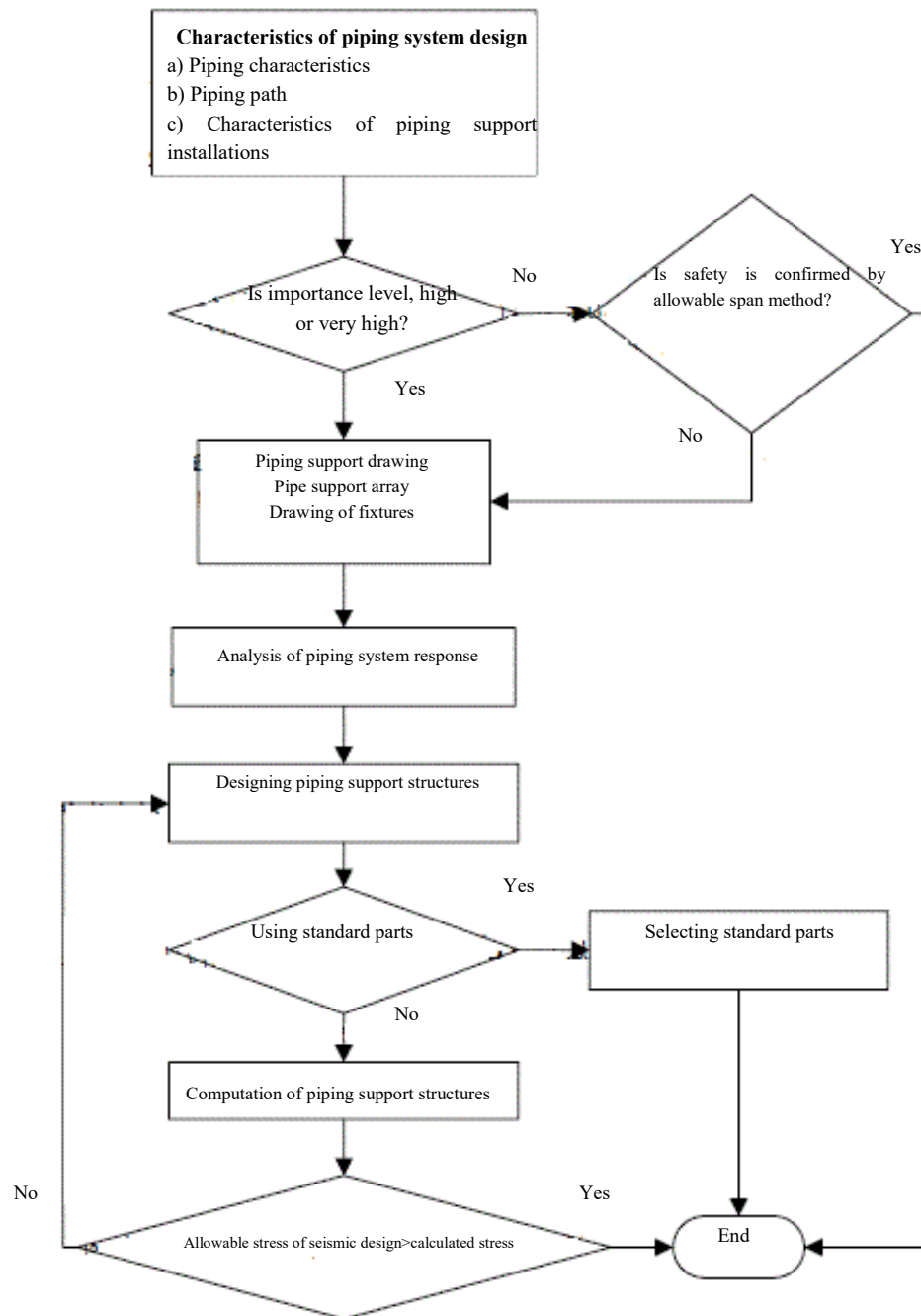

Figure 21-Steps of seismic function evaluation of pipe support

1-3-Analysis of piping system response

Loading condition of pipe support is obtained from response analysis based on design condition of related pipe support provided confirmation of seismic function of components such as piping, flange junctions and valves after analysis of piping system response.



1-4-Support structural drawing

Analysis of piping system response is performed on the basis of related support map and shape and dimension of pipe support.

1-5-Evaluation of support seismic function

For evaluation of support seismic function, assumed calculative stress in section (4) must be lower than allowable stress of seismic design.

1-6-Simplified evaluation

Evaluation of seismic function may be neglected if the importance level of piping is low and the design is performed by means of allowable span method.

1-7-Standard support

If a pipe support is used that its earthquake-resistance has already been confirmed and pipe support loading condition is lower than standard load limit of pipe support, evaluation of seismic function may be neglected according to before-mentioned clause 4.

2-support function and type

Pipe support is contributed in haltering pipe displacement in pipe support point or fix point defined in the table (14).



Table 27-Function and detailed definitions of pipe support

| Classification | | Smaller classification | | Detailed definition |
|-----------------------------|--|--|---|--|
| name | function | name | function | |
| bracer | Piping load in earthquake or piping displacement harnessed due to heat deformation | brace | Displacement and rotation is braced in three direction | Converted to foxed support point |
| | | guide | Piping displacement is braces in the direction perpendicular on brace axis | Support point of piping is positioned in a direction where piping displacement is braced |
| | | u-shaped bolt or band | Displacement is braced in two directions perpendicular on piping axis | Support point of piping is positioned in two directions perpendicular on piping axis but when is bind installed to 4B piping or lower, three directions can be considered. |
| | | Axial stopper | Displacement is braced in the direction of piping axis | Support point of piping is positioned in the direction of pipe axis |
| | | Three-axial stopper | Displacement is braced in three direction of piping | Support point of piping is positioned in three direction of pipe |
| Vibration-resistant machine | Prevention from vibration and piping displacement | Liquid separator apparatus | Slow displacement is allowable but quick displacement is braced | Support point of piping is positioned in the braced direction |
| | | separator apparatus of mechanical cable type | Slow displacement is allowable but quick displacement is braced | |
| | | spring separator apparatus | Displacement is reduced by spring | Function as a spring support point, however support point in allowable span method is considered. |
| seat | Dead weight of piping is tolerated | seat | Dead weight of piping from lower face is tolerated and displacement of beneath direction is braced. | When displacement isn't occur due to weight, heat and seismic load, pipe support axis is considered in the vertical direction. |
| | | Solid joint | Dead weight of piping from upper face is tolerated and displacement of beneath direction is braced. | |
| | | Variable joint | Rebound is tolerated by springs | When displacement isn't occur due to weight, heat and seismic load, pipe support axis is considered in the vertical direction. |
| | | Constant joint | Dead weight of piping from upper face is tolerated and displacement of beneath direction is braced. | Converted into spring support but in the allowable span method, pipe support is considered in the vertical direction, |

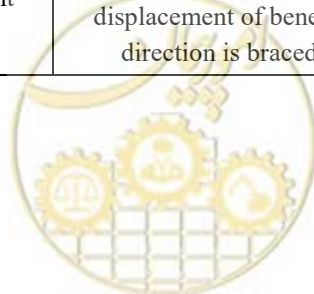

In this definition, the purpose of pipe support point is support point related to acceleration response of piping system in earthquake. Loadings such as liquefaction and load due to heat deformation in support points such as separators may not be considered in some circumstances.

3-Pipe support array

Pipe support is consisted of welded part, appurtenance seat and pipe support structure.

3-1-welded part: pivot, saddle, heat insulation material of metallic insertion, horizontal juncture, seat, etc, installed or directly welded to piping

3-2- Appurtenance seat: metallic joints such as U-shaped bolt, pipe pin and insulator, installed for maintenance or bracing pipe to frame structure, pipe rack, adjuncts and traverse (under head), etc.

3-3-Piping support structure: beam or independent single structure installed on frame structure, pipe rack, towers, containers, etc. Piping is fixed to support structure through appurtenance sest and welded components.

4-Loading conditions

Support calculations are done using exerted load from piping through table 15.

Table 28-conditions of piping loading

| Load type | Non-compressive part | Compressive pipe |
|---|----------------------|------------------|
| Dead weight of piping | ○ | ○ |
| Load due to heat stress in piping | ○ | |
| Inertia force of piping in earthquake | ○ | ○ |
| Load due to relative displacements in support structure in earthquake | ○ | ○ |

5-Calculated stress

According to structure type, pipe support stress may be calculated on the basis of analytic and standard method indicated in the table 16 in the mentioned components in the following:

5-1-pillar

5-2-beam

5-3-brace

5-4-foundation bolt

5-5-important components special to seismic design

5-6-allowable stress of support seismic design

According to type of compressive section material and material of support structure, various allowable stresses are applied for seismic design. Minimum value between allowable stresses of seismic design of compressive section and material of support structure is used as an allowable stress for material of support structure that directly welded to compressive section material. Welded or installed support structure material must be selected among material listed in the left column of the table 16 based on metal type of compressive section.



Table 16-Calculated stresses of pipe support

| | Section | Analytical and standard technique |
|-----------------------------|--------------------------------------|--|
| Pressure-resistant material | Welding parts (circle and rectangle) | WRC-107 (1979), ASMECASE-391, CASE-392-3, and FEM analysis |
| | Welding parts (planar material) | ASMECASEN-318-5 and FEM analysis |
| | Welding parts (saddle) | FEM analysis |
| Non-compressive material | Structural part of Welding part | Design standard of metallic structure |
| | Welding parts (saddle) | FEM analysis |
| | Installation metallic material | Design standard of metallic structure and FEM analysis |
| | Support material | Design standard of metallic structure and FEM analysis |

Compressive section materials are materials that stress is produced in them due to primary internal pressure and non-pressure materials are different from materials of compressive section.

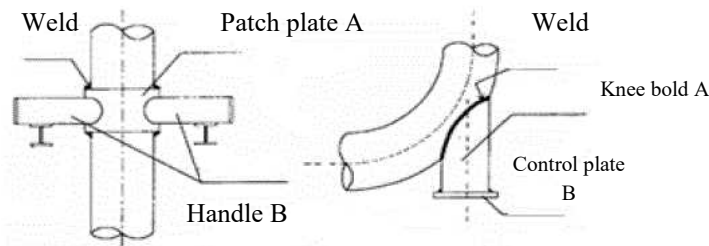

A: Part which is needed to study allowable stress for seismic design of pressurized material while manufactured of support structure.

B: part for which only allowable stress of seismic design for support structure is applied.

Figure 21-material of compressive section and material of support structure

-allowable stress of seismic design for materials of non-compressive section of support

Allowable stress of seismic design for materials of non-compressive section of support is indicated in the clause 3-4.

-allowable stress of seismic design for support pressure-resistant materials

Allowable stress of seismic design for support pressure-resistant materials is explained with detail in the clause 3-4.

6-Overlooking evaluation of seismic function

If support part of pipe and in same loading condition, resulted tensions is less than allowable stress of seismic design, calculations related to separate evolution of seismic design of various parts can be overlooked.



3-12-Flowchart of piping seismic design through ductile method

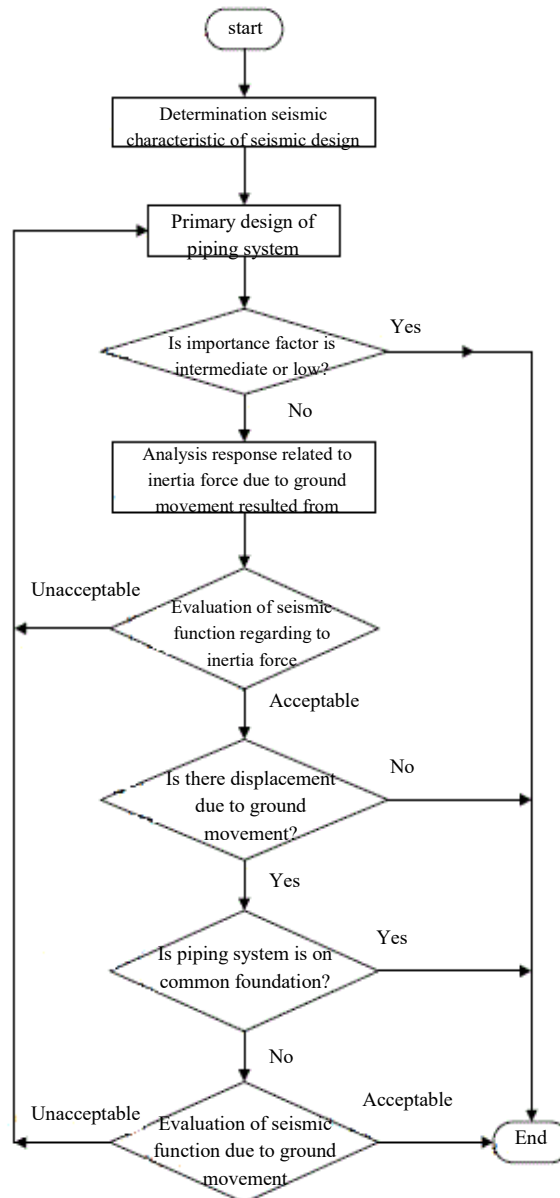
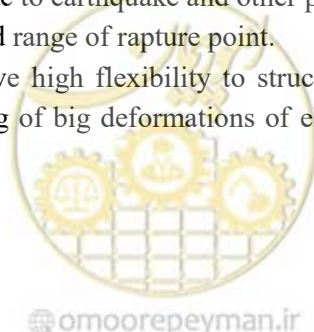

Figure 22- Flowchart of piping seismic design through ductile method

3-13-Evaluation of pipe bending in big deformations

According to good flexibility of steel pipes and their high deformability, these pipes don't quickly reach the rupture point even if the deformation in these pipes exceeds the range of yield stress. When these pipes undergo big deformations due to earthquake and other phenomena, it is essential to know their style of deformation after yield point and range of rapture point.

In piping system, elbowed pipes give high flexibility to structural system with regard of structural characteristics. So, proper understanding of big deformations of elbowed pipes as principal components



of this system is essential for seismic strength evaluation of piping systems including pipes and their supports.

If pipe bent undergoes moment resisting momentum M , angle change θ (which is called bend angle, afterward) is obtained from equation (12) based on beam theory. In this relation, spherical (distortion) effect is considered.

$$\theta_B = k_e 90 \frac{R_1}{EI} M \quad (12)$$

Where

K_e Flexibility factor in elastic deformations ($K_e=1.65/h_d$)

h_d characteristic value of moment-resisting deformation ($h_d = \bar{T} R_1 / r_2^2$)

\bar{T} Pipe thickness (mm)

E Longitudinal elastic module (N/mm^2)

r_2 mean radius of pipe (mm)

R_1 bent radius of pipe (mm)

I inertia moment of section (mm^4)

θ_B bent angle (degree)

Equation (12) helps significantly in quantities understanding big deformations of bent pipe with consideration of plastic deformation. This relation is converted to relation (13).

$$\theta_B = k_p 90 \frac{R_1}{EI} M \quad (13)$$

Where K_p is flexibility factor in plastic deformation. Approximate value of flexibility factor in in-plane bending mode, in-plane expansion and ex-plane bending are given in following correspondingly, using results from non-linear analysis of pipe with 90 degree bent by means of finite element method.

Approximate relation for in-plane bending mode:

$$k_p = \left[(1.25h_d + 0.33)\theta_B (90/\alpha_p) - 0.48h_d + 0.4 \right] \frac{S_o}{S_y} k_e \geq k_e \quad (14)$$

Approximate relation for in-plane expansion mode:

$$k_p = \left[(1.28h_d + 0.03)\theta_B (90/\alpha_p) - 0.66h_d + 0.75 \right] \frac{S_o}{S_y} k_e \geq k_e \quad (15)$$

Approximate relation for ex-plane bending mode:

$$k_p = \left[(1.1h_d + 0.24)\theta_B (90/\alpha_p) + 0.15h_d + 0.19 \right] \frac{S_o}{S_y} k_e \geq k_e \quad (16)$$

Approximate relation for mean bending, in-plane expansion and ex-plane bending:

$$k_p = \left[0.37 + (h_d + 0.25)\theta_B (90/\alpha_p) \right] \frac{S_o}{S_y} k_e \geq k_e \quad (17)$$

Where



| | |
|------------|---|
| α_p | Pipe bent angle (degree) |
| S_y | yield strength or equivalent strength of yield using 0.2% strain of material (N/mm ²) |
| S_0 | 215 N/mm ² |

With consideration of maximum equivalent plastic strain in elbowed pipe, approximate relation of various character value of pipe with 90 degree bent is obtained using characteristic parametric study of big deformations of in-plane bending (bending and expansion) and ex-plane bending using finite-element method.

$$\theta_B = 29.1 \frac{(\varepsilon_{eq}^p)^{0.829}}{h_d^{0.456}} \quad (18)$$

Plastic strain ε_{eq}^p is equivalent plastic strain and obtained from relation (19).

$$\varepsilon_{eq}^p = \sqrt{\frac{2}{3} \left[(\varepsilon_x^p)^2 + (\varepsilon_y^p)^2 + (\varepsilon_z^p)^2 + 2(\varepsilon_{zx}^p)^2 + 2(\varepsilon_{xy}^p)^2 \right]} \quad (19)$$

Where

| | |
|--|------------------------------|
| ε_{eq}^p | Equivalent plastic strain |
| $\varepsilon_x^p, \varepsilon_y^p, \varepsilon_{xy}^p, \varepsilon_{zx}^p, \varepsilon_{yz}^p$ و ε_z^p | Components of plastic strain |

3-14-Flowchart of inertia force and response displacement



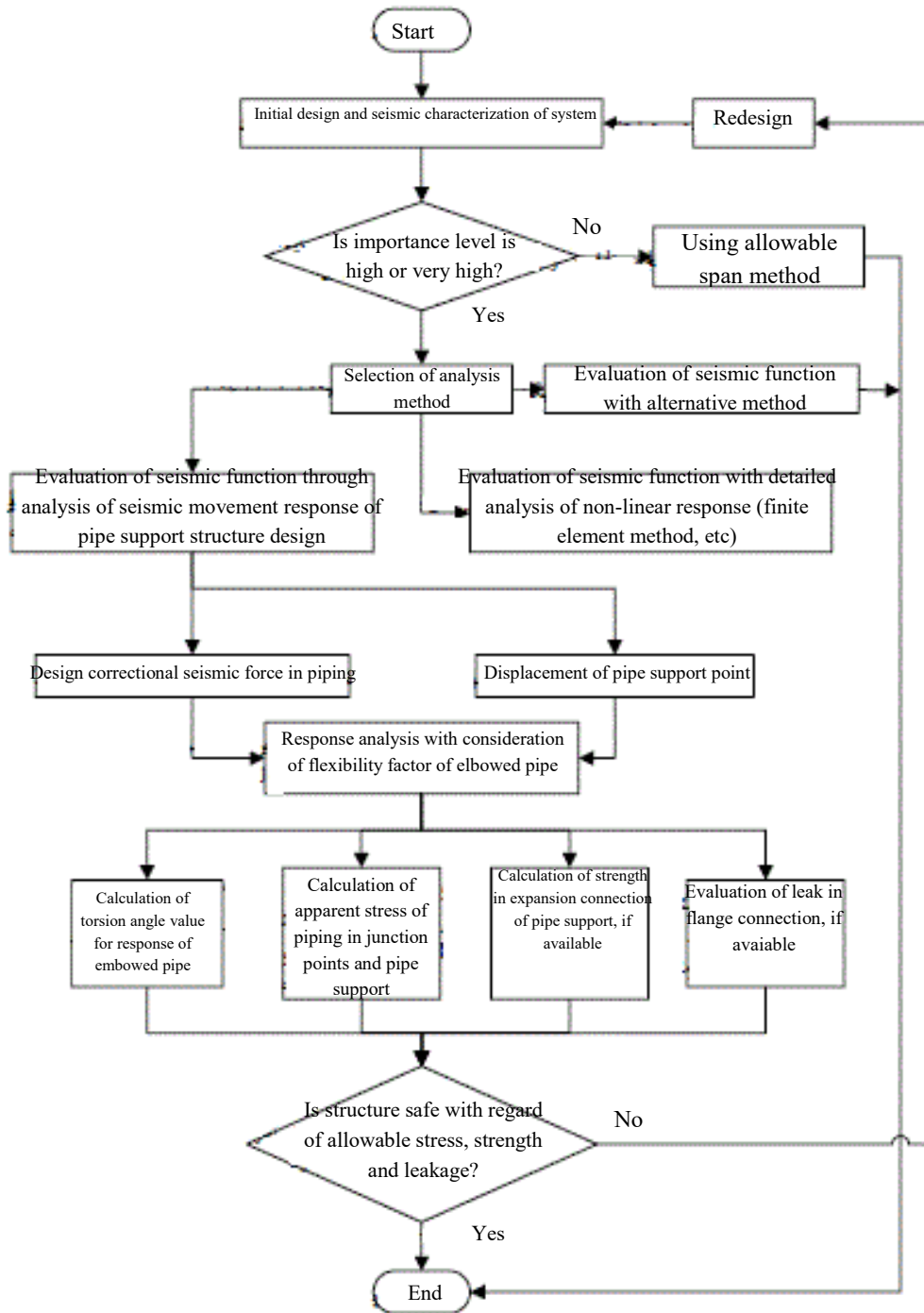

Figure 23-Flowchart of inertia force and response displacement



3-14-1-Method of derivation response displacement of pipe support point through corrected semi-static approach

1-Response displacement of pipe support point of containers and towers

In clause 3, the calculation method of piping design seismic intensity in pipe support points through semi-static approach is presented. Response displacement of pipe support point of containers and towers is calculated from relation (20) as following:

$$\delta_x = \begin{cases} \left(\mu_p + 1 \right) \frac{K_y}{K_{MH}} \delta_{xMH} & \mu_p < 0 \\ \delta_{xMH} & \mu_p = 0 \end{cases} \quad (20)$$

Where

- δ_x The value of horizontal displacement of pipe support point in earthquake (mm)
- μ_p ductility factor of pipe support structure (towers and containers) by corresponding value with rupture mode in which μ_p has its maximum value (see relation 4-1, chapter 4).
- K_{MH} Corrective horizontal seismic factor of the design, related to pipe support structure (containers and towers)
- δ_{xMH} Horizontal displacement of response (mm) in pipe support structure in containers and towers related to corrected semi-static approach of the design K_{MH} . Response displacement is calculated through one of three methods including corrected semi-static method, modal analysis or analysis of time history response with replacement of pipe support structure (containers and towers) with suitable vibration system model.

2-Displacement of pipe support point in framed structures

Calculation method of response displacement in pipe support point of framed structures through semi-static method is presented together with an example of a framed structure by assumption of shear deformation model. Response displacement and displacement of intermediate stories related to i^{th} story is calculated from relation (21). The value of i is varied between 1 and 4.

$$\Delta Y_i = s_i \Delta X_i \quad Y_i = Y_{i-1} + \Delta Y_i \quad (21)$$

Where

- Y_i Response displacement in story i , $Y_0=0$ (mm)
- ΔY_i Relative displacement of story in i^{th} story, $\Delta Y_i=Y_i-Y_{i-1}$ (mm)
- s_i ratio of displacement in i^{th} story that is calculated from relation (22) but its value is equal or more than 1.

$$s_i = 1 + \mu_{pi} = 1 + \frac{1}{4C} \left\{ \left(\frac{K_{MHi-1}}{K_{MHi}} \right)^2 - 1 \right\} \quad (22)$$

K_{MHi} is calculated from relation (23):

$$K_{MHi} = \min(K_{MH(i-1)}, K_{yi}) \quad \text{but} \quad K_{MH0} = K_{MH} \quad (23)$$

Where

K_{yi} is yield seismic factor in i^{th} story which its value is given by relation (24):

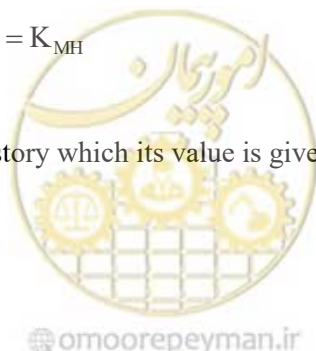

$$K_{yi} = \frac{Q_1}{\mu W_1 + \dots + \mu_4 W_4} \quad (24)$$

K_{MH} is corrective horizontal seismic factor for pipe support structure design (frame) that is calculated from relation (25).

$$K_{MH} = \beta_5 K_H \quad (25)$$

Where

β_5 Horizontal response magnification factor

K_H Horizontal seismic factor related to design seismic force in the ground surface

ΔX_i i^{th} relative in terms of K_{MH1} (mm) that its value is given by relation (26):

$$\Delta X_i = K_{MH1} \frac{\mu_1 W_1 + \dots + \mu_4 W_4}{k_i} \quad (26)$$

Where

W_i Level load in i^{th} story (kN)

K_i springy of i^{th} intermediate story (kN/mm)

Q_1 yield strength (kN)

μ_i distribution factor of seismic intensity in i^{th} story (see relation 10-16, chapter 10)

μ_{pi} ductility factor in i^{th} story (that is calculated from relation 20)

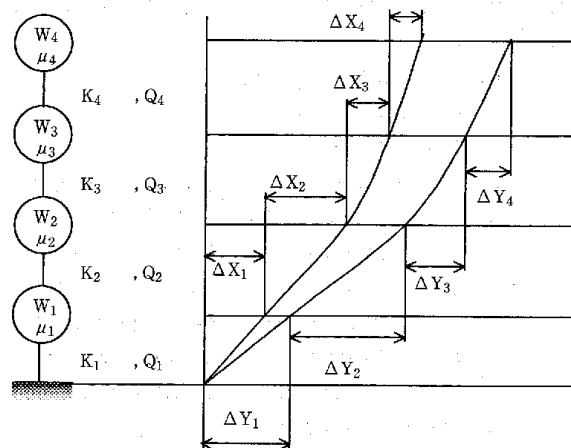

Figure 24-Relative displacement of i^{th} story

3-14-2-equivalent linear analysis, detailed analysis and response magnification factor

1-Equivalent linear analysis

1-1-Outline

It is appear rationally to use evaluation by equivalent linear model for the purpose of easing design for designing piping system in plastic mode. Equivalent linear model is used in analysis of elbowed pipe using flexibility factor (k_p) in plastic region. This factor (k_p) is obtained by modification of flexibility factor (k_e) in elastic region using flexibility characteristic value and angular displacement. Although according to analytical results, flexibility factors of in-plane

bending, in-plane expansion and ex-planar bending have different values, but same correction factors are used for them. With consideration of making no difficulty in the accuracy of the problem, lower frequency of small torsion angle than to allowable ultimate ductility factor and duplication of positive and negative deformation, these correction factors are assumed to have the same value.

1-2-Plasticity factor of elbowed pipe

In pipes of 90 degree bent, mean flexibility factor is determined with consideration of small angular deformations and frequent positive and negative shifts of deformation. Flexibility factor, k_p , is obtained by referring to relation (15) for in-plane bending, in-plane expansion and ex-plane bending (in this relation, θ_D must be used instead of θ_B). However, k_p is equal to 1.0 with assumption of torsion. Moreover, in the pipes with bent of 45 or 60 degree, etc. angle of allowable displacement is derived through interpolation.

1-3-Equivalent linear analysis procedure

Method of Equivalent linear analysis is applied according to following procedure.

Behavior of elbowed part of pipe is assumed as its equivalent ductile factor and then, whole system is analyzed. In this manner, flexibility factor for bending angle due to resultant of loads composition is considered.

Convergence of calculation is done until flexibility factor obtained from calculations, in terms of bend angle is conformed to assumed value. In these calculations, ductility factor is convergence criterion and calculation is considered as convergent when its error is about 5%. Value of angular displacement of bent is obtained as mean least square of relative displacement of angle in three directions between junction of two points of bent and direct pipe.

Calculations are confirmed when angular displacement of bent obtained from analytical result of whole system is lower than allowable angular displacement.

Except for bent part, evaluation of calculation in other parts is done by stress as it shouldn't be in plastic range.

1-4-Condition of equivalent linear analysis method

Following assumptions are considered in the case of equivalent linear analysis method:

Non-linear displacement and characteristic of frictional load of supports and cracks (looseness), etc are not considered.

Inertia force and response displacement are applied in one direction.

According to operational load composition and seismic load, the worst direction in the composition is considered.

Table 17 presents composition of loads.



Table 17- Composition of operational load and seismic load

| Load type Stress type | Seismic load | | Operational pressure | Fluid pressure |
|--|--------------------------|---------------|----------------------|----------------|
| | Relative displacement | Inertia force | | |
| Longitudinal stress σ_1 | | ○ | ○ | ○ |
| Range of alternative stress σ_E | ○)support structure(| ○ | | |

2-Detailed analysis

In detailed analysis by means of finite element, etc. there is a method called hybrid (composite) method, in which elbowed pipe, T-shaped pipe and their equivalents are modeled using shell element or spatial element and direct pipe as beam element. In elbowed pipe where non-linear behavior is indicated using section flattening, analysis is performed with consideration of non-linear behavior of materials and geometry (big deformations). However, suitable value obtained from material tension test must be used for yield strength and rate of non-linear cold hardening of materials.

Elasto-plastic analysis of pipe using beam model by means of finite element method can be applied for analysis of non-linear element of bent pipe (elbow). Although vibration of both system of support and piping must be analyzed but for facilitation of work, acceleration and displacement obtained from response analysis in support point may be applied as a seismic force to piping.

Equivalent plastic strain is obtained from relation 27:

$$\varepsilon_{eq}^p = \sqrt{\frac{2}{3}} \sqrt{(\varepsilon_x^p)^2 + (\varepsilon_y^p)^2 + (\varepsilon_z^p)^2 + 2(\varepsilon_{yz}^p)^2 + 2(\varepsilon_{zx}^p)^2 + 2(\varepsilon_{xy}^p)^2} \quad (27)$$

Where

ε_x^p , ε_y^p , ε_z^p , ε_{yz}^p , ε_{zx}^p and ε_{xy}^p components of plastic strain

3-Response factor of magnification

In earthquakes of high intensity, effect of energy wastage in elasto-plastic behavior of elbowed pipes is predictable. In addition, the effect of decrease in non-linear response of friction or support gap, etc. is high. Reduction effect of displacement response in additional decay effect due to high hazard level earthquakes is predictable because of existence of about 3-5 mm gap in pipe support in the direction perpendicular to support of high pressure gas piping system. This effect especially is significant in cases where support structure exerts high response due to flexibility and has high flexibility as a result of piping shape and support type.

In evaluation of piping system with equivalent decay ratio method that uses spectrum of frictional system response, reduction in response is appeared due to effect of frictional decay effect.

For example, according to an experimental calculation, magnification response factor in frictional system with one degree of freedom (decay factor of 2%) in equivalent frictional decay

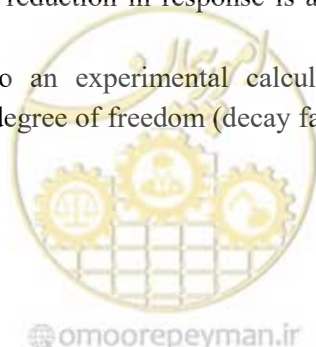

factor is about 1.5 based on type of the ground using a value resulted from division of frictional force on input acceleration.

In seismic response analysis of piping system, magnification response factor is obtained as following through using equivalent linear beam model:

- 1-Although magnification factor of horizontal response in pipe support structure is assumed to be 2, but pipe supports that have sliding surfaces and energy wastage effect exists in them is considered to be 1.5.
- 2-In all cases, magnification response factor in vertical direction is equal to be 2.
- 3- Magnification response factor is obtained with exchange of absorbed energy as a result of non-linear behavior with a suitable equivalent decay constant.

3-14-3-Evaluation of rupture modes of bent pipe, junction pipe and direct pipes and details of undulatory deformation of pipe

1-Evaluation of rupture modes of bent pipe

Bent pipe is evaluated using allowable angular deformation. Allowable angular deformation is obtained under conditions in which allowable plastic strain of bent is 2%. This bent is calculated through parametric study of characteristic bent's big deformations in two modes of in-plan (bend and expansion) and ex-plan bend in compare with various characteristic value of elbowed pipe using finite element method.

$$\theta_{aL2} = 29.1 \frac{\varepsilon_{paL2}^{0.829}}{h_d^{0.456}} \quad (28)$$

Where ε_{paL2} is equivalent plastic strain and θ_{aL2} is allowable angular displacement. This relation is for pipe with bent of 90 degree and for pipes with bent of 30 and 45 degree, allowable angular displacement is computed through interpolation.

As a result, torsion angle of bent pipe with consideration of maximum plastic strain and according to allowable ultimate plastic deformation regarding acceleration response is equal to half of range, or equal to 2% such that in half amplitude of 2%, $\varepsilon_{paL2} = 0.02$ in equivalent plastic strain. So, torsion angle is computed as relation (29).

$$\theta_a = \frac{1.14}{h_d^{0.46}} \quad (29)$$

Where

θ_a is allowable angle of bent pipe (in terms of degree).

Table 18 shows relation between characteristic values of bent deformation and allowable angle of high radius elbow of 90 degree. In this regard, allowable plastic strain is assumed to be 2%.

2-Evaluation of rupture modes for junction pipes and direct pipes

Since in response analysis, junction pipe and direct pipe are modeled as linear beam element and existence of destabilizing phenomena such as buckling due to high strain is unacceptable so as an alternative, same evaluation is used for safety.

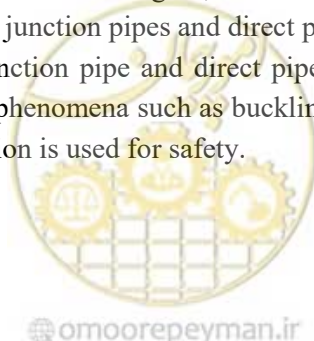

3- Wavy shape deformation

Wavy shape deformation is progressive non-elastic deformation. Non-elastic strain changes per each period frequently. Constant-shape wavy deformation occurs when net non-elastic strain due to alternative known load is constant in next cycle.

There is probability for increase of progressive non-elastic deformation in the apparatus and piping. This increase is due to addition of frequent variation of mechanical secondary stress, heat secondary stress or both of them to a place where first stress resulted from internal pressure and dead weight is higher than a certain limit.

For example, in elbowed pipe, increase in the amount of progressive non-elastic deformation occurs a result of overlapping of primary stress with internal pressure and a mechanical alternative secondary stress, such that tensile stress of pipe wall is produced in the surrounding of the pipe because of internal pressure and excess applied alternative load through seismic loading. So it is essential that primary and secondary stress in that unit be remained in the allowable range to prevent excess plastic deformation or progressive deformation. In equivalent linear method in elbowed pipe, as explained in section 1, reception criterion is the value of allowable displacement that is obtained by assumption of allowable ultimate plastic deformation equal to be 2% in the half of amplitude in equivalent plastic strain.

Table 18-allowable angle in high radius elbow of 90 degree

| Allowable angle (degree) | Characteristic value of bending displacement | Wall thickness (mm) | External diameter (mm) | Nominal diameter | |
|-----------------------------|--|---------------------------|---------------------------|------------------|-----|
| | | | | (B) | (A) |
| 1.69 | 0.420 | 3.7 | 48.6 | 1-1/2 | 40 |
| 1.79 | 0.371 | 3.9 | 60.5 | 2 | 50 |
| 1.75 | 0.392 | 5.2 | 76.3 | 2-1/2 | 65 |
| 1.82 | 0.360 | 5.5 | 89.1 | 3 | 80 |
| 1.89 | 0.331 | 5.7 | 101.6 | 3-1/2 | 90 |
| 1.94 | 0.312 | 6.0 | 114.3 | 4 | 100 |
| 2.03 | 0.283 | 6.6 | 139.8 | 5 | 125 |
| 2.11 | 0.260 | 7.1 | 165.2 | 6 | 150 |
| 2.23 | 0.231 | 8.2 | 216.3 | 8 | 200 |
| 2.32 | 0.213 | 9.3 | 267.4 | 10 | 250 |
| 2.39 | 0.198 | 10.3 | 318.5 | 12 | 300 |
| 2.39 | 0.200 | 11.1 | 355.6 | 14 | 350 |
| 2.39 | 0.200 | 12.7 | 406.4 | 16 | 400 |
| 2.39 | 0.200 | 14.3 | 457.2 | 18 | 450 |
| 2.45 | 0.189 | 15.1 | 508.0 | 20 | 500 |
| 2.50 | 0.181 | 15.9 | 558.8 | 22 | 550 |
| 2.49 | 0.183 | 17.5 | 609.6 | 24 | 600 |
| 2.49 | 0.182 | 18.9 | 660.4 | 26 | 650 |

14-4-Details of design procedure for flange connection and required contact pressure of washer

1-Procedure of seismic function evaluation



Figure 26 shows procedure of seismic function evaluation in flange connection. In fact, required seismic function in flange connection is equal to insulation degree of connection for passage of high pressure gas due to effect of existent load in piping.

Leak from washer is evaluated using washer factor, which is obtained by conversion of axial tension force F and bending moment M due to seismic load to the equivalent pressure in the washer plate.

1-1-Piping axial force and bending moment in flange connection is calculated from analysis of acceleration response and piping displacement.

1-2-Leakage evaluation is done in such a way that required connection pressure of washer must be lower than connection pressure of washer in the first step of bolt tightening. Required connection pressure of washer is equal to sum of applied pressure on washer due to internal pressure of pipe and pressure equal to axial force and calculated bending moment in piping.

2- Required connection pressure of washer in simple evaluation of leakage

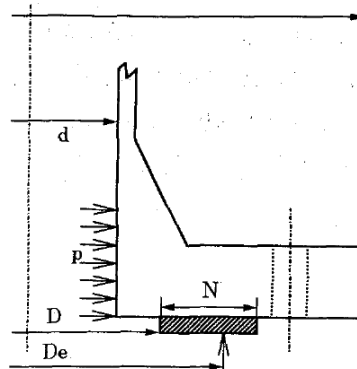

Figure 25-Edge of seat plate of washer

Equal internal pressure resulted from axial force F and bending moment M due to seismic load in planar fays washer is given as relation 30.

$$p_e = \frac{4F_g}{\pi D_e^2} + \frac{16M}{\pi D_e^3} \quad (30)$$

Where

F_g axial force due to seismic load (N)

M bending moment due to seismic load (N.mm)

D_e mean diameter in connection face of washer (mm), $D_e = D_{1G} + 2(N_g - b_g)$

D_{1G} Internal diameter of washer (mm)

N_g washer width (mm)

b_g effective width of washer (mm)

So required connection pressure of washer $y_b n_{svqgsi} p_{eq}$ Relation 31.

$$p_{eq} = mp + \alpha p_e \leq \sigma_a \quad (31)$$

In this relation, m is washer factor and α is correction factor of leakage pressure due to load resulted from equal internal pressure (0.75m).

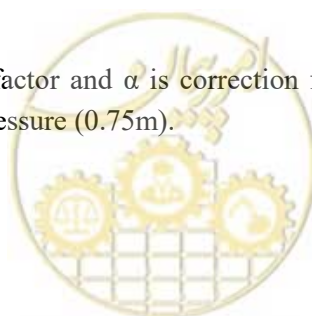

In the connection of flange with bolt in pipe, joint implementation isn't possible. In this case, converted stress due to primary tightening for each bolt as conventionally used before is known. As a result, connection pressure of washer due to primary tightening of bolt is computed simply on the basis of bolt number, cross section of all bolts and washer size with least standard diameter.

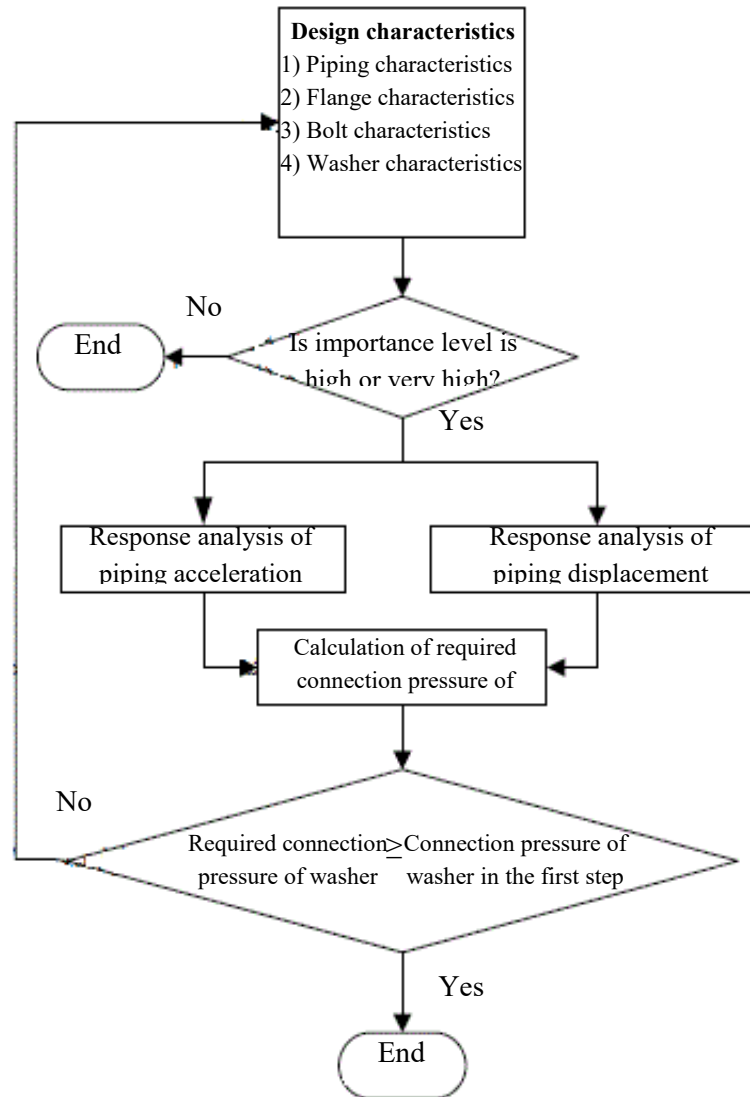

Figure 26-Evaluation of seismic function of the flange connection

3-14-5-Details of expansion connection evaluation

1-calculation of total value of axial stress

Total value of axial stress in expansion connection is given by a method similar to the allowable stress method

2-Evaluation

Figure 27 shows the flowchart for evaluation of seismic function in the expansion connection. In piping system involving expansion connection, for evaluation of seismic function in the expansion connection, relative displacement in both ends of connection must be lower than allowable displacement in 50 times vibration. Especially, total value of maximum axial stress produced in

accordion part of expansion connection due to relative displacement of support structure in both ends must be lower than total value of allowable stress corresponding to 50 times allowable cycle for relevant connection materials. In this manner, it is possible to estimate axial relative displacement and relative displacement in the direction perpendicular to the axis, separately. Evaluation is done in such a way that maximum total axial stress in accordion must be lower than twice of value of allowable stress corresponding to 50 times allowable cycle obtained from figures of Japan standard Institute B8281 “analysis of stress and rupture of compressive container” (1993) according to accordion materials.

a- Allowable stress, S_a in seismic design of axial stress produced in accordion part of expansion connection made from hard steel (carbonized), low alloy steel, ferrite stainless steel and high tension strength steel is equal to following values:

- When minimum tensile strength is equal or lower than 551.6 MPa, $S_a = 2 \times 1896 = 3792 \text{ MPa}$

- When minimum tensile strength is in the range of 792.9-896.3 MPa, $S_a = 2 \times 1586 = 3172 \text{ MPa}$

- When minimum tensile strength is in the range of 551.6-792.9 MPa, it is obtained appropriately from value of a) and b).

b- Allowable stress used in seismic design produced in expansion connection accordion made from austenitic stainless steel, nickel alloy (Ni-Cr-Fe and Ni-Fe-Cr alloy) and Ni-Cu alloy is equal to be $S_a = 2 \times 2379 = 4758 \text{ MPa}$.

3-Expansional connections for purposes other than earthquake movement

In piping systems that expansion connections other than designed connection for design's seismic movement are available, pipe support must be designed in such a way that displacement of expansion connection is not exceeded from tolerance limit due to seismic movement of the design or support of expansion connection must have adequate strength to maintain function of displacement bracing component (bracing through bolt rack, rack plate, adjustment ring, etc) and contain applied reaction computed through analysis of pipe system response due to ground movement.



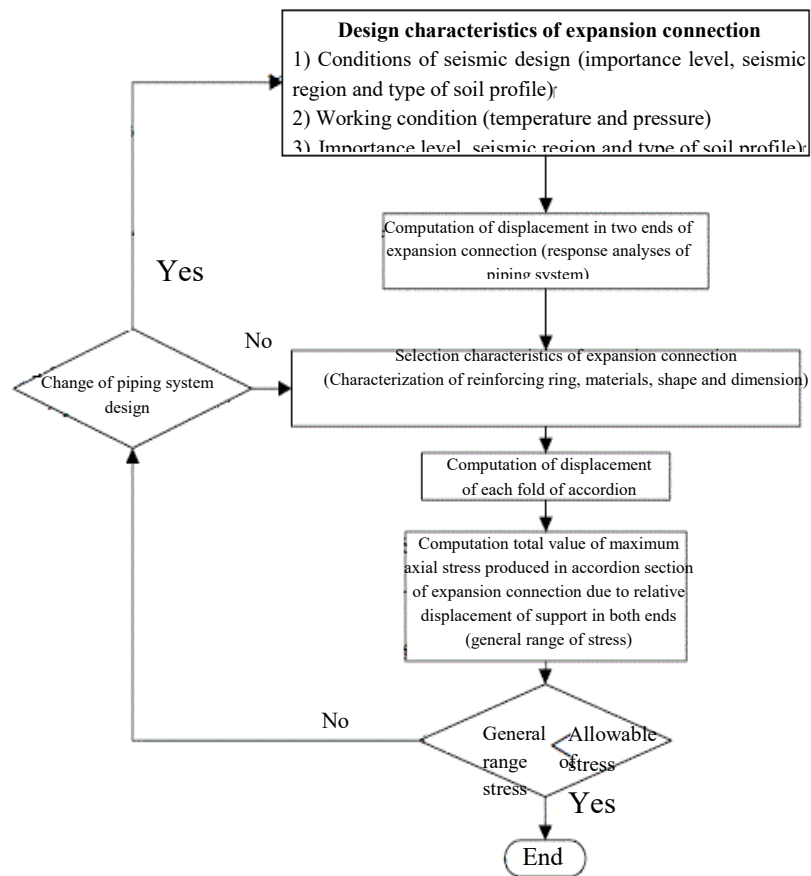

Figure 27-flowchart of seismic function evaluation of expansion connection



3-14-6-Details of spray evaluation of towers and containers

Figure 27 shows flowchart of seismic function evaluation of expansion connection for towers and containers with simplified method based on the Bairard method. Stress intensity for sprays of towers and containers in piping system is computed on the basis of load related on horizontal seismic force of the design, vertical seismic force of the design and displacement of pipe support point.

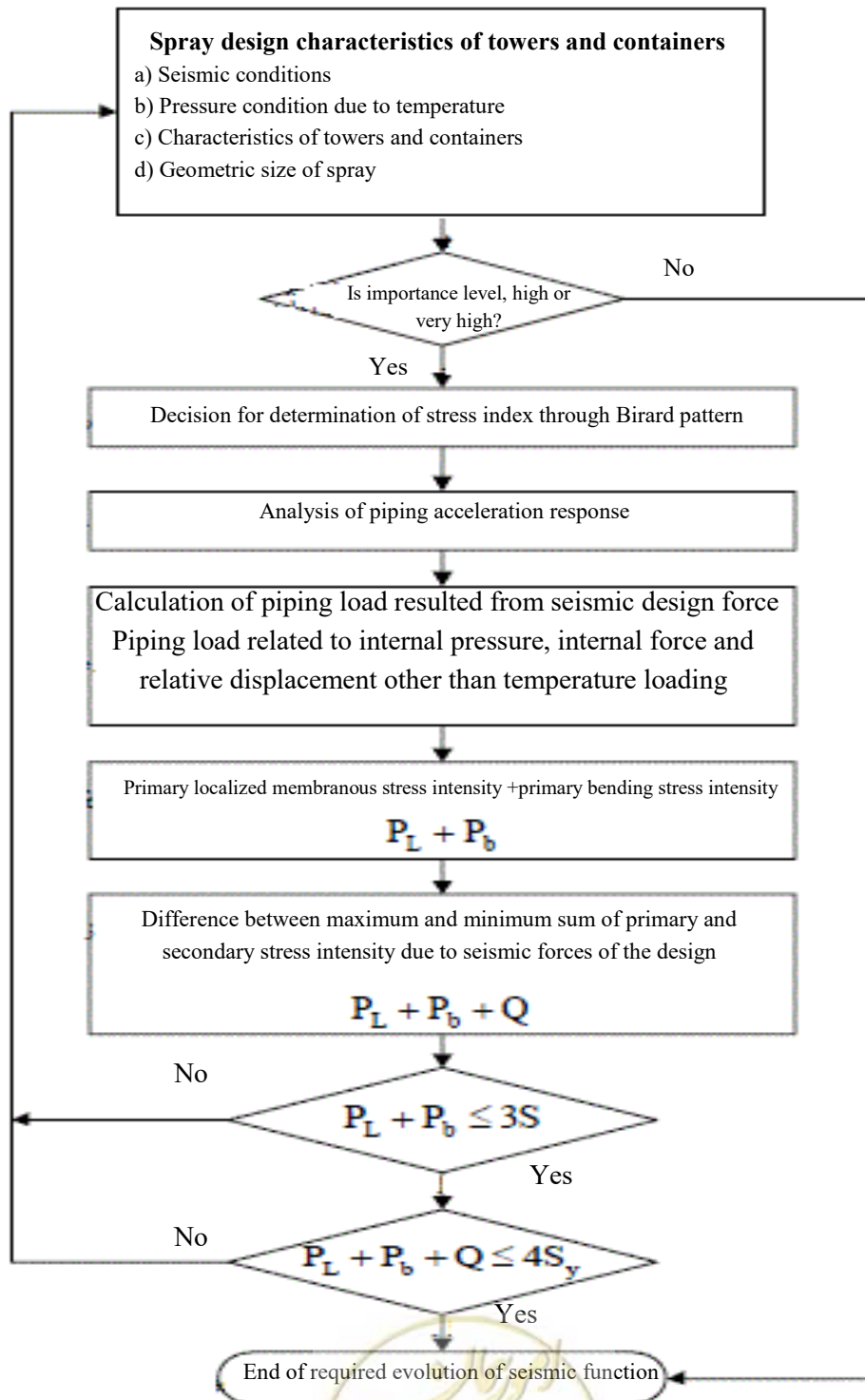

Figure 28- Flowchart of required seismic function evaluation in sprays of towers and containers due to inertia force

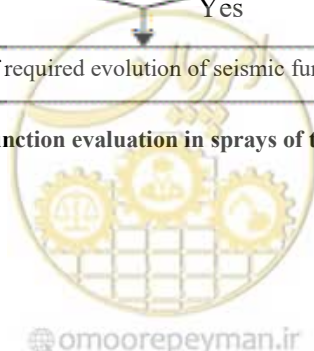

Table 19 presents allowable stress intensity in seismic design of towers and containers

Table 19-Allowable stress intensity in seismic design of towers and containers

| Allowable stress intensity in seismic design | Stress type | Number |
|--|--|--------|
| 3S | Primary localized membranous stress intensity+ primary bending stress ($P_L + P_b$) | 1 |
| 4S _y | Difference between maximum and minimum sum of primary and secondary stress intensity due to seismic movement of design in one cycle ($P_L + P_b + Q$) | 2 |

Computations method of spray stress of towers and containers is a simplified method (Bairard method) based on thin shell theory in the field of investigation of compressive container or detailed analysis by means of the finite element method (FEM), etc.

Procedure of detailed analysis using finite element method, etc. is similar to the simplified procedure.

3-14-7-Evaluation of required seismic function in pipe support

1- Evaluation procedure of required seismic function in pipe support

Figure 29 shows the evaluation procedure of required seismic function in pipe support (pipe support structure, appurtenance seat and weld metal components).

1-1-Pipe support function (support function) is to confine piping displacement or fixing it. All effects of earthquake on piping are applied on its support. In earthquake, ground movement (acceleration and displacement) and pipe support displacement due to liquefaction and ground displacement (that are called input seismic conditions the rafter) are applied on pipe support as an input in its support point. With adequate adjustment of pipe support, effect of earthquake movement on piping and its support structure (or piping system) is reduced.

1-2-Conditions of support loading and analytical response model of piping system

In evaluation of seismic function, analytical response model of piping system is adjusted for each of input conditions based on pipe support function.

In addition to pipe support function, piping support function (function of constraining deformation and enduring load due to seismic force), piping bracing, control seismic input of piping and freeing pipe support function due to ground movement are presented.

1-3-Allowable conditions of seismic force of the design in pipe support point

Response analysis of piping system inertia force is performed using acceleration and displacement of pipe support point due to earthquake movement that is explained in clause 14 of Appendix.

Produced force in support point that is obtained from response analysis is varied according to inertia force loading conditions of pipe support. Response analysis of ground movement in piping system is performed just like as analysis of pipe support point displacement. Produced displacement in support point that is obtained from response analysis is varied according to ground movement loading conditions in pipe support.

1-4-Evaluation of required seismic function



If function evaluation of allowable conditions is not acceptable, design change is performed and the mentioned procedure is duplicated until seismic function is conformed to changed characteristics.

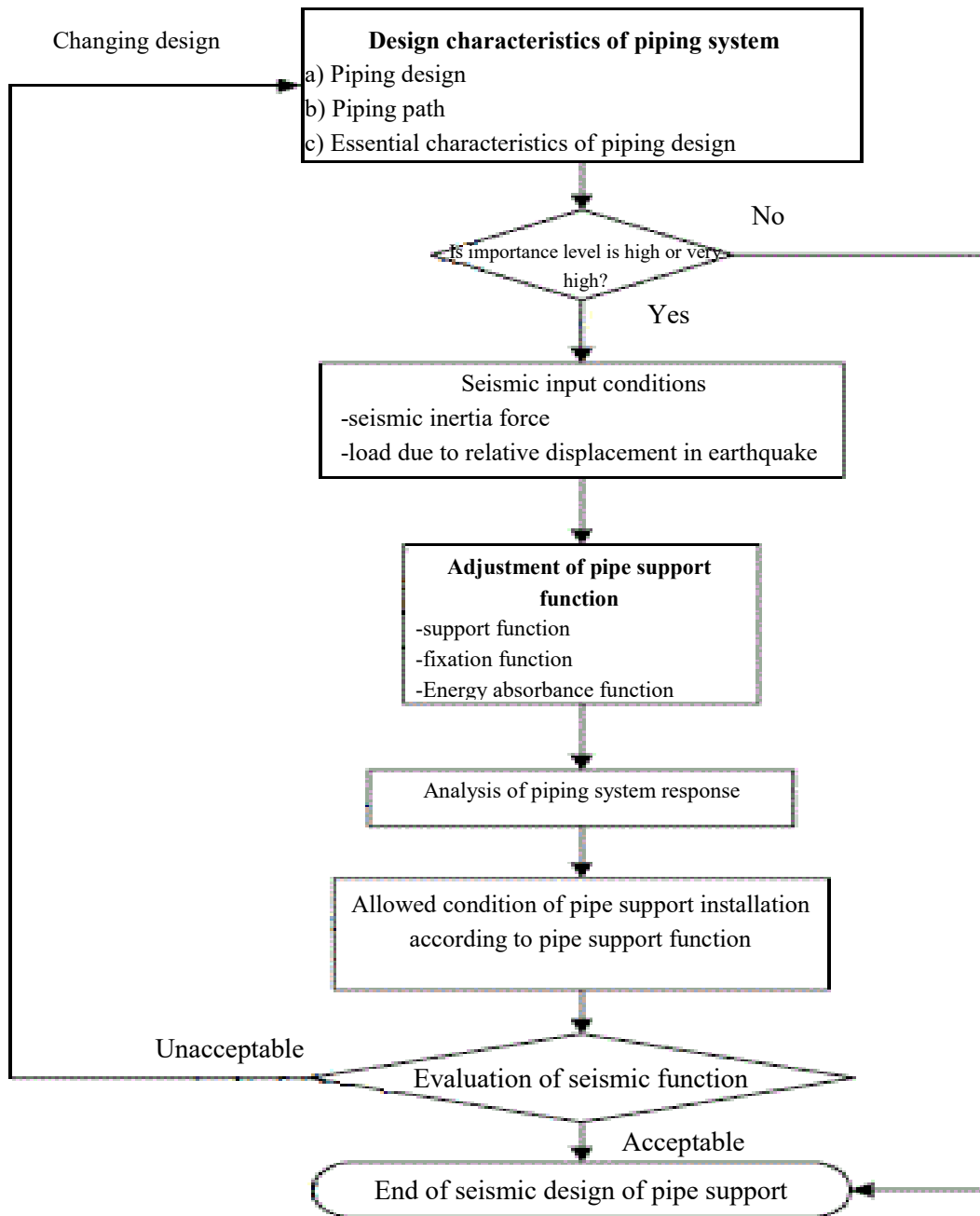

Figure 29-evaluation required seismic function in pipe support

2-Function of pipe support and allowable conditions

In the following, pipe support function (pipe support structure, appurtenance seat and weld metal components) is presented for maintaining seismic function of piping against leakage of high pressure gas. Maintenance of intended function is necessary during and sfter occurrence of earthquake.

2-1- Support function



In fact, tolerance of piping reaction or bracing its displacement in earthquake due to response acceleration of ground movement or displacement due to ground liquefaction is the actual function of support. Although plastic deformation is allowable in the case of one-pipe support that has relevant function, support load must not be lower than loads that leading to rupture or (destruction load) buckling. In this manner, for appurtenance seat that doesn't have the capability of absorbing deformation after plastic deformation step such as hinges or insulators and has composite function between components, stress produced from seismic load must be lower than yield stress.

2-2-Fixation function

In fact, dynamic independence of piping from two sides of pipe support or prevention of reciprocal deleterious effect is a function. In a supports involving related function, separation of analytical model of piping response can be considered. In fixed support of pipe (that is called fixed support of pipe or brace, thereafter) formed stress in pipe support due to reaction or moment due to deformation and rotation in three direction must be lower than yield stress.

2-3-Function of energy absorbance

Absorbance of earthquake energy through installation of seismic separators (and whatnot) in pipe support and control seismic input due to earthquake movement in piping is accounted a function. Pipe support must have following qualifications to fulfill this function:

Response displacement must be lower than allowable displacement

Plastic displacement of energy absorbent must be lower than deformability of energy absorbent.

According to energy absorption in pipe support, it is conceived that function confirmation is necessary.

3-Loading condition

Table 20 present evaluations on the basis of applied loads on piping.

Table 20-Loading condition of piping

| Load type | Non-compressive components | Compressive components |
|--|----------------------------|------------------------|
| Load due to piping weight (pressure and weight) | ○ | ○ |
| Load due to heat stress of piping | ○ | |
| Inertia force in piping due to earthquake | ○ | ○ |
| Load due to relative displacement in support structure due to earthquake | ○ | ○ |

4-Allowable condition of pipe support

Allowable condition of pipe support is considered according to load characteristics and their deformations. Figure 30 shows specifications of load and deformation. In this figure, dashed part indicates difference in data. Yield load, limit state load and releasing load are defined as follow:

Yield load

Yield load is equal to value of design's yield load of, F_{yd} or lower than values indicted in figure 30.

Limit state load

Limit state load is equal to minimum rapture load, F_n (minimum load that leads to destruction) or than values indicted in figure 30.

Releasing load



Releasing load is equal to maximum rupture load, F_x (maximum load that leads to destruction) or than values indicted in figure 30.

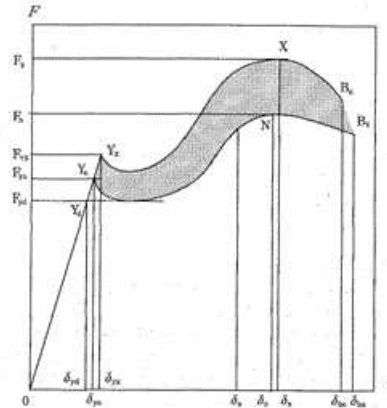
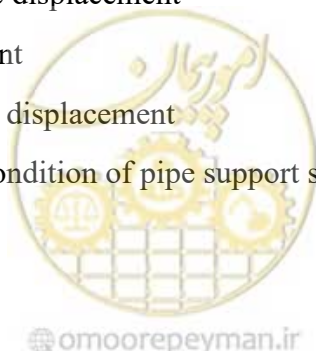

Figure 30-Bold diagram and deformation of piping support structure

- F_{yx} Maximum yield load
- δ_{yx} Maximum yield displacement
- Y_x Maximum yield strength
- F_{yn} Minimum yield load
- δ_{yn} Minimum yield displacement
- Y_n Minimum yield strength
- F_{yd} Yield load of design
- δ_{yd} Yield displacement of design
- Y_d Yield strength of design
- δ_a Allowable displacement
- F_x Maximum rupture capacity (maximum load of destruction)
- X Location of rupture maximum capacity
- F_n Minimum rupture capacity (minimum load of destruction)
- N_r Location of minimum rupture load
- δ_{bx} Maximum rupture displacement
- B_x Location of maximum rupture displacement
- δ_{bn} Minimum rupture displacement
- B_n Location of minimum rupture displacement

5-Calculation method of allowable condition of pipe support structure



5-1-Yield load of pipe support

Yield load of used materials are described in clause 3-4 of material.

5-2-Limit state load of pipe support structure: limit state moment

Limit state moment is as follow:

a) When moment affects around strong axis of H-shaped section and main axis of can-shaped section:

$$\text{If } \frac{N}{N_r} \leq \frac{A_w}{2A} \text{ then } M_{pc} = M_p \quad (32)$$

$$\text{if } \frac{N}{N_r} > \frac{A_w}{2A} \text{ then } M_{pc} = 1.14 \left(1 - \frac{N}{N_y} \right) M_p \quad (33)$$

b) When moment affects around weak axis of H-shaped section

$$\text{If } \frac{N}{N_r} \leq \frac{A_w}{A} \text{ then } M_{pc} = M \quad (34)$$

$$\text{If } \frac{N}{N_r} > \frac{A_w}{A} \text{ then } M_{pc} = 1.14 \left\{ 1 - \left(\frac{N - N_{wY}}{N_Y - N_{wY}} \right)^2 \right\} M_p \quad (36)$$

In this case, $N_{wY} = A_w \sigma_Y$

c) Plastic moment due to joint effect of bending moment around strong axis M_x , bending moment around weak axis M_y and axial force in these positions M_{pcx} and M_{pcy} are obtained correspondingly from clauses a) and b).

$$\left(\frac{M_x}{M_{pcx}} \right)^2 + \frac{M_y}{M_{pcy}} = 1 \quad (36)$$

d) Design relation of components

Compressive axial force N and maximum bending moment M_1 must be fulfilled in the following relation.

$$\frac{N}{N_{er}} + \frac{C_M M_1}{\left(1 - \frac{N}{N_E} \right) M_{er}} \leq 1.0 \quad (37)$$

$$\frac{M_1}{M_{cr}} \leq 1.0 \quad (38)$$

N Axial pressure (N)

N_E Euler buckling strength in bending face (N)

N_{er} minimum strength value against buckling (N)

M_{pc} bending plastic moments due to compressive force (N.mm)

M_1 absolute value of greater moment affect in both ends of pillar (N.mm)

M_2 absolute value of smaller moment affect in both ends of pillar. When component undergoes simple deflexion, moment is positive and when component undergoes double deflexion, moment is considered negative (N.mm).

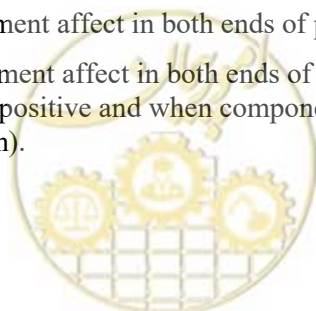

M_{cr} strength of lateral buckling when there isn't any compressive axial force (N.mm). when moment is existed around weak axis of can-shaped section, H-shaped section and steel pipe, it is assumed that $M_{cr} = M_p$.

C_M Factor related to distribution of bending moment when bending moment affect around strong axis.

$$C_M = 0.6 + 0.4 \frac{M_2}{M_1} \geq 0.4 \quad (39)$$

$$C_M = 1 - 0.5 \left(1 - \frac{M_2}{M_1} \right) \sqrt{\frac{N}{N_E}} \geq 0.25 \quad (40)$$

6-Calculation method of allowable condition for U-shaped bolt

6-1-Yield load of U-shaped bolt is as following:

$$F_{L1z} = \frac{\pi}{4} d_b^2 \sigma_{by} \quad (41)$$

$$F_{L1y} = 2 \frac{\pi}{4} d_b^2 \sigma_{by} \quad (42)$$

6-2-Limit state load value of U-shaped bolt is as following:

$$F_{L2z} = 0.7 \frac{\pi}{4} d_b^2 \sigma_{bBu} \quad (43)$$

$$F_{L2y} = 1.4 \frac{\pi}{4} d_b^2 \sigma_{bBu} \quad (44)$$

F_{L1z} : Yield load in the direction perpendicular to the pipe axis of U-shaped bolt (N)

F_{L1y} : Yield load in the direction perpendicular to U-shaped bolt (N)

F_{L1y} : Yield load in the direction perpendicular to U-shaped bolt (N)

F_{L2z} : Limit state load in the direction perpendicular to the pipe axis of U-shaped bolt (N)

F_{L2y} : Limit state load in the direction perpendicular to U-shaped bolt (N)

d_b for steel U-shaped bolt (mm)

σ_{bBu} : Rapture stress of U-shaped bolt (N/mm²)

In the next table, an example of computed load from above-mentioned clauses is given. In these calculations, material type of U-shaped bolt is assumed to be SS400.



Table 21-Allowable load of U-shaped bolt †

| Limit state load | | Yield load | | db | External diameter of pipe | Nominal diameter of pipe |
|------------------|------|------------|------|----|---------------------------|--------------------------|
| FL2 y | FL2z | FL1 y | FL1z | | | |
| kN | kN | kN | kN | mm | mm | B |
| 44 | 22 | 38 | 19 | 10 | 48.6 | 1-1.2 |
| 44 | 22 | 36 | 19 | 10 | 60.5 | 2 |
| 44 | 22 | 38 | 19 | 10 | 76.3 | 1-1.2 |
| 63 | 32 | 55 | 28 | 12 | 89.1 | 3 |
| 63 | 32 | 55 | 28 | 12 | 101.6 | 3-1.2 |
| 63 | 32 | 55 | 28 | 12 | 114.3 | 4 |
| 113 | 56 | 99 | 49 | 16 | 139.8 | 5 |
| 113 | 56 | 99 | 49 | 16 | 165.2 | 6 |
| 113 | 56 | 99 | 49 | 16 | 190.7 | 7 |
| 176 | 88 | 148 | 74 | 20 | 216.3 | 8 |
| 176 | 88 | 148 | 74 | 20 | 241.8 | 9 |
| 176 | 88 | 148 | 74 | 20 | 267.4 | 10 |
| 253 | 127 | 213 | 106 | 24 | 318.5 | 12 |
| 253 | 127 | 213 | 106 | 24 | 355.6 | 14 |
| 253 | 127 | 213 | 106 | 24 | 406.1 | 16 |
| 253 | 127 | 213 | 106 | 24 | 457.2 | 18 |
| 253 | 127 | 213 | 106 | 24 | 508.0 | 20 |
| 253 | 127 | 213 | 106 | 24 | 558.8 | 22 |
| 253 | 127 | 213 | 106 | 24 | 609.6 | 24 |

7-Calculation method of allowable condition of other appurtenance seat

7-1-yield load

Yield load of material is explained in clause 4-3-material

7-2-Limit state load

Limit state load is considered to be 1.5 times of yield load.

8-Calculation method of allowable condition for joints with weld

8-1-yield load

Yield load of used material is explained in clause 4-3-material

7-2-Limit state load

Limit state load is 1.5 times of yield load.

15-Flexibility of piping system and seismic design procedure due to ground liquefaction

1-Providing flexibility of piping system

Providing flexibility of piping system of piping system is depends on methods of clauses 1-1 to 1-3 or a combinative method.

1-1-Piping ring method

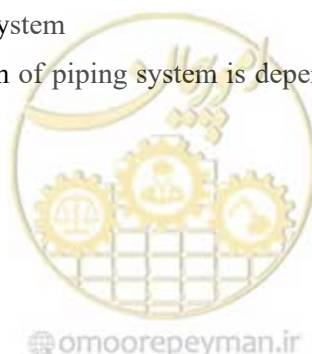

In this method, relative displacement among support points is absorbed through insertion of piping ring among related support points. Relative displacement is braced in three directions with formation of piping ring.

1-2-Method of flexible pipe

In this method, relative displacement among support points is absorbed through insertion of flexible pipes among related support points.

1-3-Method of pipe free support

In this method, high flexibility exists in system and relative displacement is absorbed using supports with releasing function of displacements due to ground displacement in foundation. With movement of piping foundation (settlement and horizontal displacement of ground due to liquefaction), high displacement is apparent in piping system that may damage other surrounding structures such as adjacent small pipes (pipe belongs topping system) in the intersection of these structures with system. So it is necessary to be noticed.

2-Procedure of seismic function evaluation of piping system to displacement of foundation due to ground displacement

Figure 31 shows procedure of seismic function evaluation of piping system to displacement of foundation due to ground displacement

2-1-This evaluation is performed in the state of liquefaction

2-2-If piping foundation together with first support of pipe is constructed on the same foundation after seismic safety valve, seismic function evaluation of relevant piping system due displacement resulted from ground movement in foundation is acceptable.

2-3-When piping system cannot be constructed on one common foundation, it is necessary to confirm flexibility of piping system and impossibility of leakage of high pressure gas from piping due to relative displacement of foundation according to proposed function or results of investigations

3-Response analysis and range of seismic function evaluation due to ground movement

3-1-Piping system on common foundation

In order to secure seismic strength of high importance piping system due to ground movement, this system is constructed on common foundation and first support point after seismic safety valve is fixed using welding (or any other method). On the other word, related pipe support must be fixed to prevent leakage due to deformation of weak pipe support as a result of loading from ground movement.

In the example of figure 33, to secure seismic function of hatched section (a), influence of hatched section (b) due to ground movement is analysed and evaluation of seismic function is performed for fixed support of pipe and foundation of hatched section (c) according to fixation function of that part due to ground movement. It is preferred that seismic function of piping system due to ground movement in the analysed section to be confirmed.

3-2-Piping on non-common foundations

Piping system must have adequate flexibility against ground movement. According to flexibility evaluation of piping system in example of figure 34, in which evaluation of hatched section (a) is performed under influence of hatched section (b) due to ground movement and seismic function of hatched section (c) is evaluated, it is preferred to perform similar evaluation of piping system in analyzed extent. However, analysis of hatched section (b) is depends on the analytic model that simulate excellently deformation mode of piping, piping support structure and its foundation as a result of ground movement.

3-3- No-fixing support on common foundation

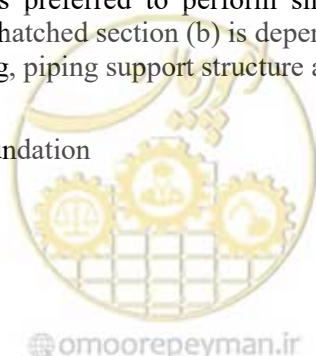

If piping system is to be building on common foundation but first support of pipe next to seismic safety valve is not fixed due to its position on common foundation, evaluation of seismic function due to ground movement is performed according to procedure in clause 2.

4-Evaluation of seismic function of piping system with free support as a result of ground movement

In piping system with free support, it is required that seismic function of system to be confirmed both against maximum reaction of free support and effect of displacement due to ground movement.

4-1-In this case for seismic function evaluation of piping design, procedure shown in picture 32 is used instead of following range shown by shading in figure 33.

-evaluation of seismic function of pipe support against maximum reaction

- a) Maximum reaction (that is called releasing reaction, thereafter) is calculated when support is free.
- b) Relative displacement (that is called releasing displacement, thereafter) is obtained using analysis and with consideration strength of free support against releasing reaction.
- c) At first, axial force, bending moment, shear force and support reaction resulted from released displacement are computed and then, seismic function of system is evaluated. In this case, evaluation procedure of primary force may be applied.



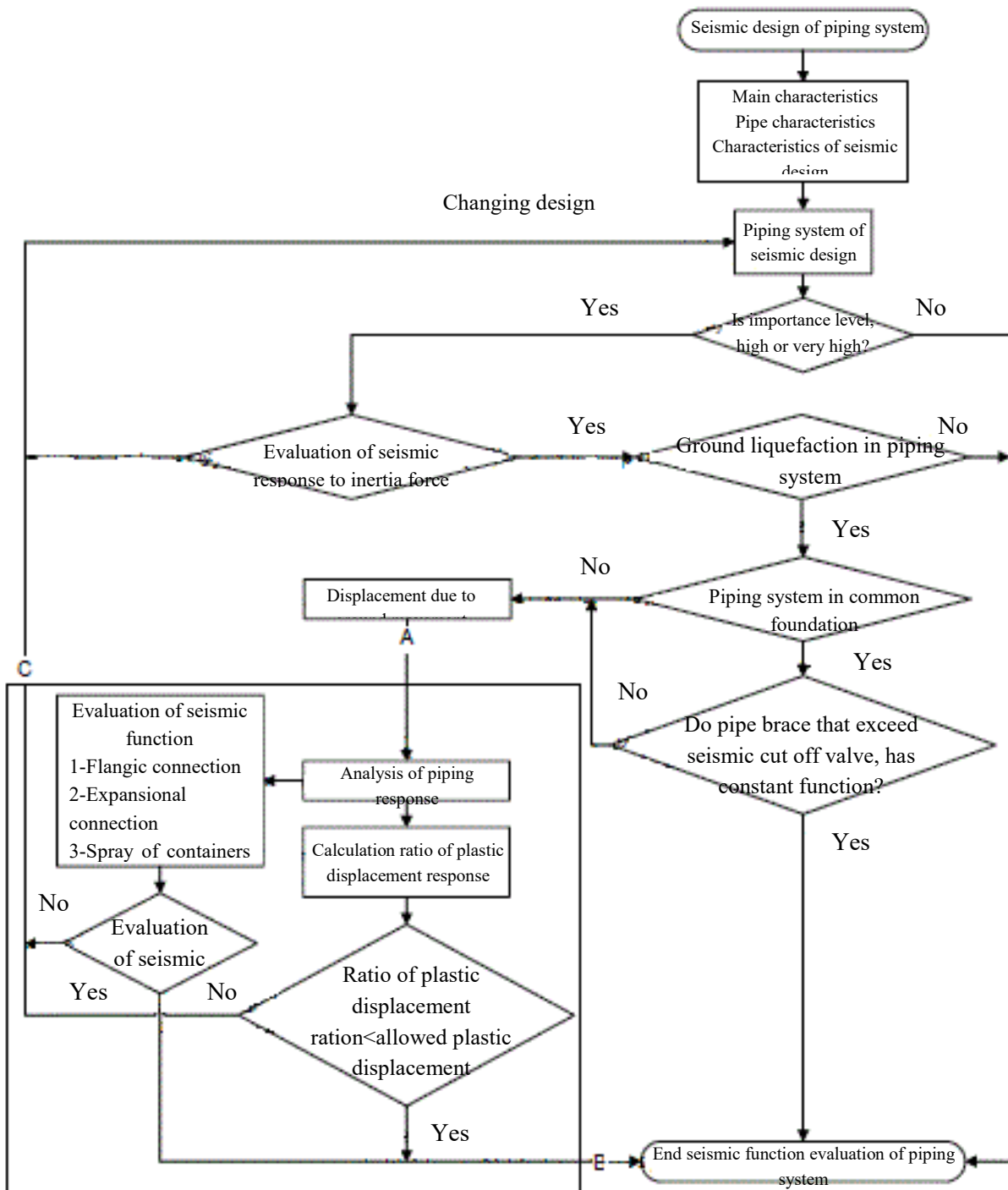

Figure 31-Steps of seismic function evaluation of piping system for ground movement

e) If intended seismic design is not fulfilled, design procedure must be changed. When only design method of free support is changed (reduction of maximum reaction) it is not necessary to go back to first step of seismic function evaluation. Seismic function evaluation of piping system reaction against inertia force must be performed separately.



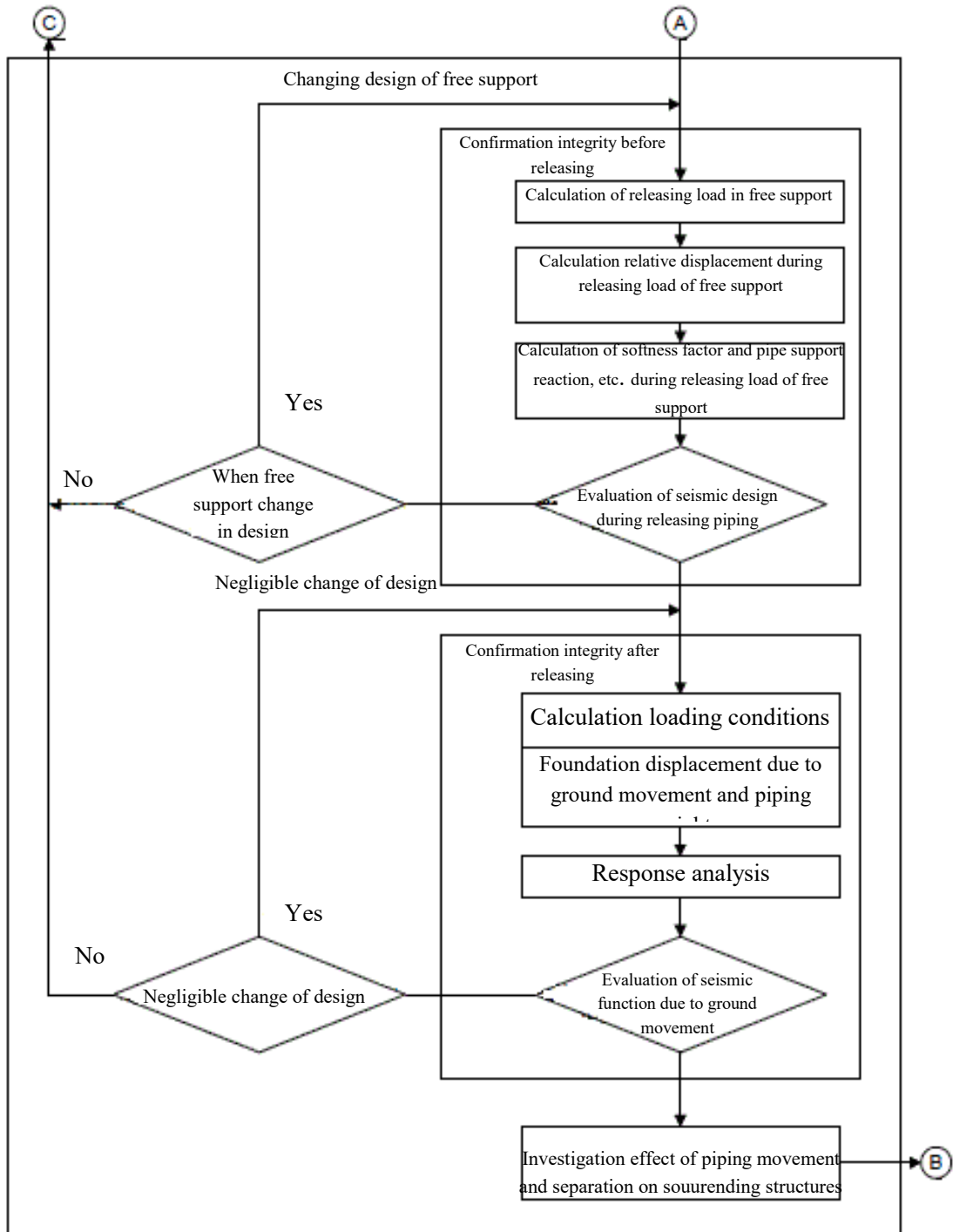

Figure 32-Flowchart of seismic function evaluation of piping system with free support due to ground movement



4-2-Confirmation seismic function of piping system (تست عملکرد لرزه ای سیستم لوله کشی در مقابل زمین لرزه)

- a) In response of foundation displacement due to ground movement as a result of reaction and separation of piping system from free support and with assumption of missing support efficiency, pipe weight and load due to relative displacement in a point are composited and analyzed.
- b) In evaluation of piping function against ground movement in common foundation, reaction and separation (and whatnot) of fixed support must be controlled. it is better that this control be performed in free support of piping.
- c) If piping system is not built on common foundation, evaluation of piping system and piping support structure must be performed. In this manner, loading condition due to own weight of system must be evaluated as well as evaluation of displacement loading due to ground movement.
- c) If seismic function is not fulfilled, design must be changed. If trivial changes imported in the design, evaluation is restarted from the first step.

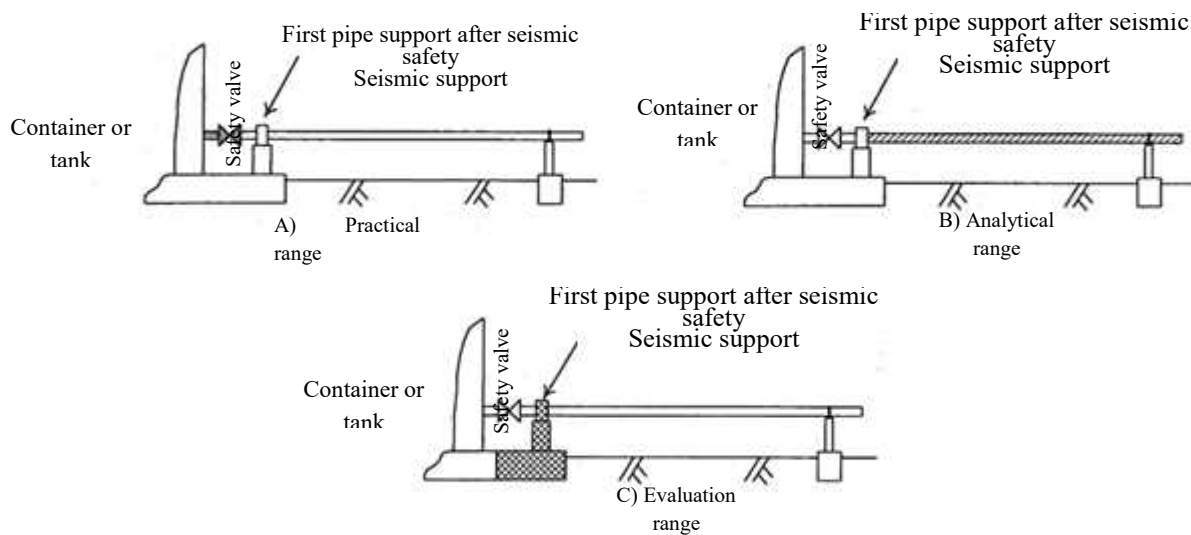

Figure 33-Piping system on common foundation

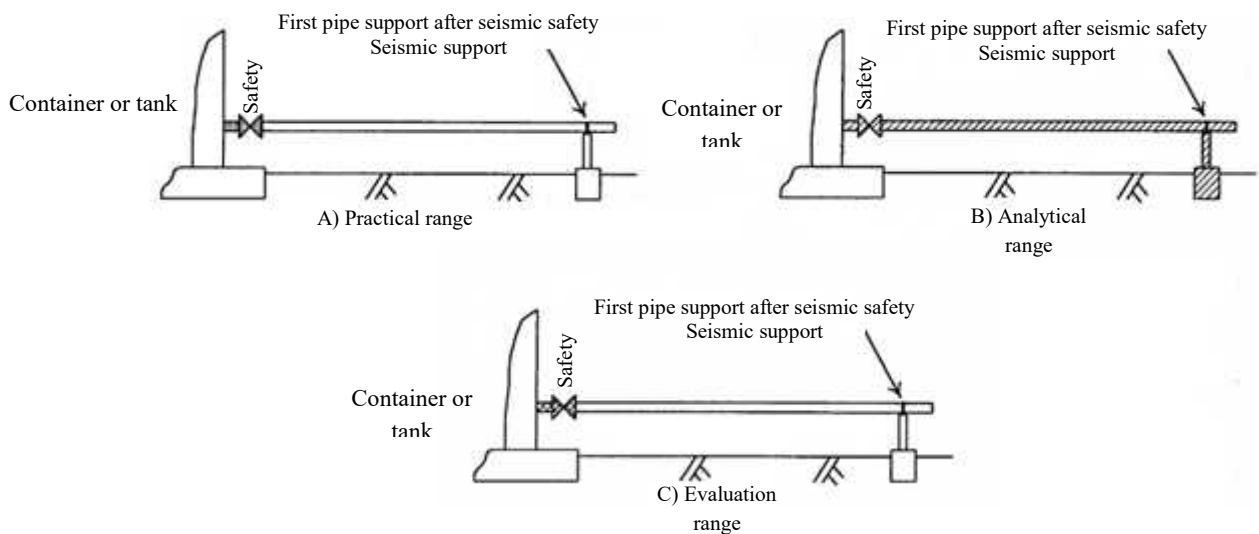

Figure 34-Piping system on non-common foundation

16-Displacement and relative displacement among foundation

1-Evaluation of foundation seismic function due to ground movement

Horizontal displacement, settlement and rotation (deviation) is occurred due to ground liquefaction, settlement and resultant horizontal displacement. Principally, piping support point must be built on common foundation but due to impossibility of whole system construction on a common foundation, piping foundation is constructed separately. So, evaluation of piping seismic function due to ground movement must be performed with attention to relative displacement between piping support and foundation.

2-Foundation displacement due to ground movement

Calculation of foundation displacement due to ground movement is as follow.

2-1-Settlement due to ground liquefaction and lateral extension

Settlement in extended foundation due to liquefaction and lateral expansion of the ground is calculated on the basis of presented procedure in the second phase. In adequate bearing capacity of stanchions, settlement due to liquefaction and lateral extension of the ground don't occur.

2-2-Asymmetric settlement of foundation due to liquefaction and lateral extension of the ground

Asymmetric settlement of foundation due to liquefaction and lateral extension of the ground is calculated on the basis of presented procedure in the second phase. In adequate bearing capacity of piles, asymmetric settlement due to liquefaction and lateral extension of the ground don't occur.

2-3-Lateral displacement due to lateral extension of the ground

Lateral displacement of extended foundation due to lateral extension of the ground is calculated on the basis of presented procedure in the second phase. Lateral displacement of piles due to lateral extension is calculated on the basis of response displacement in the second phase.

3-Relative displacement of foundation due to ground movement

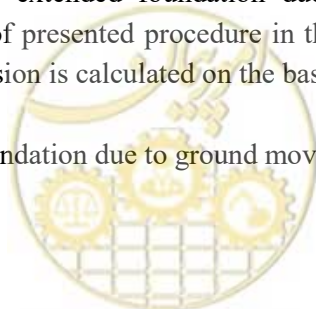

Seismic function evaluation of piping system due to ground movement is performed through calculation of relative displacement among various supports of piping and displacement of original foundation.

In this manner, relation between horizontal relative displacement $\Delta_{12}(x)$ and vertical relative displacement among foundation of supports $\Delta_{12}(y)$ is as following:

Horizontal relative displacement:

$$\Delta_{12}(x) = (x_2 + \theta_2 H_2) - (x_1 + \theta_1 H_1) \quad (45)$$

Vertical relative displacement

$$\Delta_{12}(y) = y_2 - y_1 \quad (46)$$

Parameters x_1 , x_2 , y_1 , y_2 , θ_1 , θ_2 , H_1 and H_2 are determined from following figure and table. Angle with clockwise rotation is considered positive.

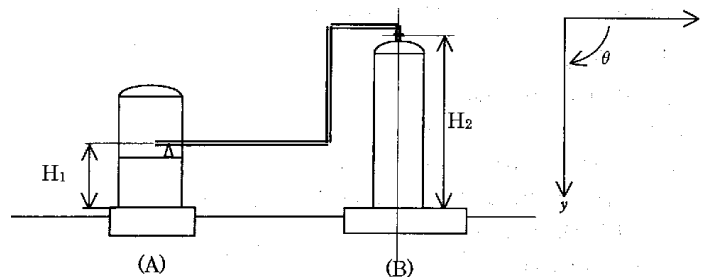

Figure 35-Pipe support structure

Table 22-foundation displacement of pipe support structure

| Pipe support structure | (B) | (A) |
|------------------------------|------------|------------|
| Horizontal displacement (mm) | x_2 | x_1 |
| Settlement (mm) | y_2 | y_1 |
| Rotation angle (rad) | θ_2 | θ_1 |

17-Flexibility factor and design procedure of elbowed pipe

1- Flexibility factor of elbowed pipe

In analysis of acceleration response, mean flexibility factor of in-plan bending, ex-plan bending and in-plan expansion are determined according to alternative negativeness or positiveness of displacement and smallness of torsion angle. However, value difference of related flexibility factor of in-plan bending, in-plan expansion and ex-plan bending cannot be neglected, because relative displacement is high and occur in one direction in response analysis of ground movement.

Although flexibility factor is obtained from relations 47 to 49 on the basis of deformation mode of elbowed pipe but for simplicity of design and disregarding deformation mode, flexibility factor for in-plan bending can be obtained as safety margin from relation 47.

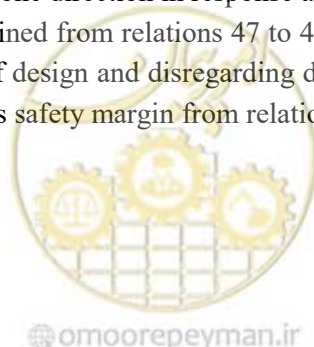

$$k_p = [(1.28h + 0.03)\theta_D(90/\alpha) - 0.66h + 0.75] \frac{S_0}{S_y} k_e \geq k_e \quad (47)$$

Where

α Angle of elbowed pipe (degree unit)

θ_D angle variation of embower pipe (degree unit)

k_e flexibility factor in elastic deformation

2-Analysis procedure

2-1-For displacement analysis of foundation due to liquefaction, relative displacement in the horizontal and vertical directions must be considered coincidentally.

2-2- Flexibility factor of elbowed pipe is obtained with consideration of corner angle and composition of relative displacement in the horizontal and vertical directions.

2-3-Composition of loads due to foundation displacement from ground displacement by a normal load is not considered. Confirmation of seismic function of system with consideration of piping weight (and whatnot) is essential when high weight is not imposed on pipe support or driven upward in vertical direction as a result of boiling phenomenon such as piping system with free support.

18-Details of allowable angle of elbowed pipe

In evaluation of seismic function due to ground movement, allowable angle of elbowed pipe is equal to torsion angle corresponding to plastic strain of 5%. Corner angle θ_{al2} , corresponding to equivalent plastic strain ε_{pal2} of elbowed pipe is given by relation 48.

$$\theta_{al2} = 29.1 \frac{\varepsilon_{paL2}^{0.829}}{h^{0.456}} \quad (48)$$

Where, ε_{pal2} is equivalent plastic strain and θ_{al2} is corner angle. This relation is for 90 degree pipe curve. For pipes with curve degree of 30 and 45, angular displacement is given through interpolation of corner angle value. In elbow of 90 degree with consideration of allowable ductility factor corresponding with plastic strain equivalent with 5%, allowable angle equivalent with ε_{pal2} 0.05 is obtained as relation 49.

$$\theta_a = \frac{2.43}{h^{0.46}} \quad (49)$$

Table 23 present the relation between allowable angles (elbowed pipe with right angle) and characteristic value of bending deformation in long arm elbow of 90 degree with nominal thickness of list 40.



Table 23-Allowable angle of long arm elbow of 90 degree (nominal thickness of list 40)

| Allowable angle (degree) | Characteristic value of bending deformation | Wall thickness (mm) | External diameter (mm) | Nominal diameter (A) |
|--------------------------|---|---------------------|------------------------|----------------------|
| 3.62 | 0.420 | 3.7 | 48.6 | 40 |
| 3.83 | 0.371 | 3.9 | 60.5 | 50 |
| 3.74 | 0.392 | 5.2 | 76.3 | 65 |
| 3.89 | 0.360 | 5.5 | 89.1 | 80 |
| 4.04 | 0.331 | 5.7 | 101.6 | 90 |
| 4.15 | 0.312 | 6.0 | 114.3 | 100 |
| 4.34 | 0.283 | 6.6 | 139.8 | 123 |
| 4.52 | 0.260 | 7.1 | 165.2 | 150 |
| 4.77 | 0.231 | 8.2 | 216.3 | 200 |
| 4.95 | 0.213 | 9.3 | 267.4 | 250 |
| 5.11 | 0.198 | 10.3 | 318.5 | 300 |
| 5.10 | 0.200 | 11.1 | 355.6 | 350 |
| 5.10 | 0.200 | 12.7 | 464.4 | 400 |
| 5.10 | 0.200 | 14.3 | 457.2 | 450 |
| 5.22 | 0.189 | 15.1 | 508.0 | 500 |
| 5.34 | 0.181 | 15.9 | 558.8 | 550 |
| 5.31 | 0.183 | 17.5 | 609.6 | 600 |
| 5.32 | 0.182 | 18.9 | 660.4 | 650 |

19-Procedure of seismic function evaluation of flange connection due to ground movement

An important point that must be kept in mind regarding seismic strength of flange connection is that leakage due to applied loads in the connection of pipes must be prevented. In this case, leakage evaluation is performed through consideration of tensile axial force and bending moment formed due relative displacement between pipe support and piping support due to ground movement in the flange connection.

Evaluation of leakage is done with a method resemble to analyse of acceleration response in clause 5-3-6. Figure 36 shows flowchart of seismic function evaluation in flange connection.



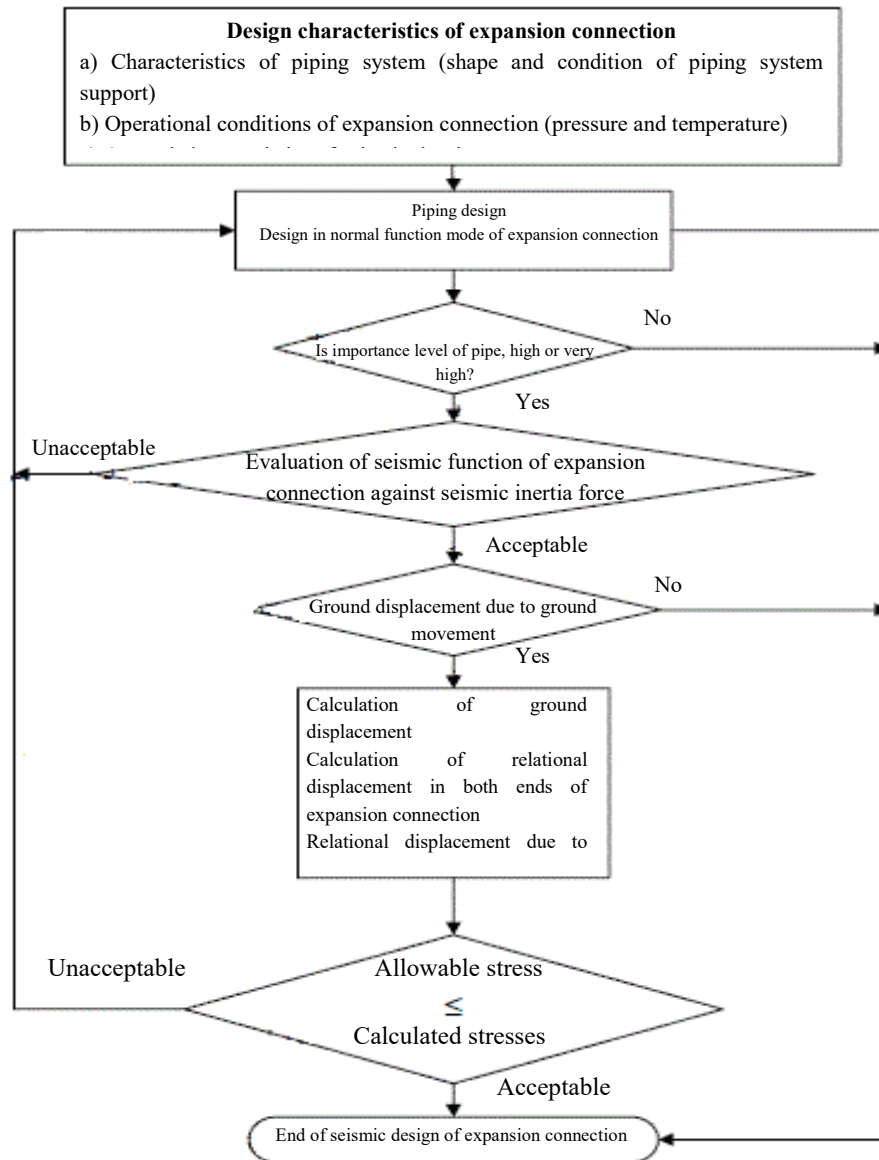

Figure 36-Procedure of seismic function evaluation of flange connection

20-Details of procedure of expansion connection evaluation due to ground movement

Relative displacement in both ends of expansion connection must be lower than allowable relative expansion displacement due to ten times vibration in expansion connection. In this case, inertia force and response displacement can be evaluated separately.

As well as direction in which relative displacement does not occur, it is necessary that connection must have adequate strength against reaction of calculated response.

1-Procedure of seismic function evaluation of expansion connection due to ground movement

Procedure of seismic function evaluation of expansion connection due to ground movement is performed according to clauses 1-1 to 1-6 as shown in figure 37.

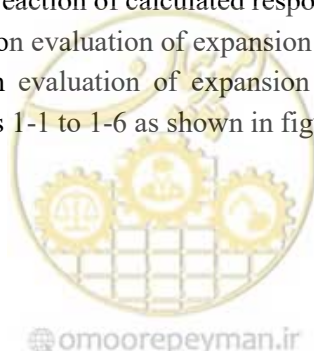

1-1- Seismic function evaluation of expansion connection with high importance due to ground movement is performed after confirmation of connection seismic function against seismic inertia force

1-2-Function of foundation against displacement due to ground movement is evaluated.

1-3-Displacement of foundation is calculated.

1-4-Analysis of piping system response is performed with concurrent consideration of horizontal and vertical displacement of foundation and relative displacement calculated in both ends of expansion connection.

1-5-Total value of produced stress in accordion part due to relative displacement between two ends of expansion connection is computed.

1-6-It must be confirmed that total value of computed stress is lower than allowable stress value.

2-Calculation method of total value of stress in expansion connection

Calculation method is as calculation method in section 8-3-5.

3-Calculation method of allowable stress value in expansion contact

Value of maximum axial stress produced in accordion part must be lower than twice of corresponding allowable stress with ten times replication.

3-1-Allowable stress S_a for seismic design of axial stress produced in accordion part of expansion contact made of hard steel (carbonized), low alloy steel, ferritic stainless steel and steel with high tensile strength is equal to following values:

a) When minimum tensile strength is equal or lower than 551.6 MPa, $S_a=2\times 3999=7998$ MPa

b) When minimum tensile strength is between 792.9-896.3 MPa, $S_a=2\times 2896=5792$ MPa

c) When minimum tensile strength is between 551.6-792.9 MPa, S_a is obtained from values in a) and b) appropriately.

3-2-Allowable stress in seismic design of produced axial stress in expansion connection accordion made from austenitic stainless steel, nickel alloy (Ni-Cr-Fe and Ni-Fe-Cr alloy) and nickel-copper alloy is equal to $S_a=2\times 4882=9746$ MPa

4-Estimation of seismic function of expansion connection due to ground movement

For estimation of seismic function of expansion connection due to ground movement, total value of calculated stress in connection from clause 2 must be lower than value of calculated stress from clause 3. In this case, accumulative damages inflicted on connection due to loads of pervious earthquakes aren't considered.

As well, displacement bracing component in expansion connection in the direction that relative displacement isn't absorbed must have sufficient strength (bracing through bolt rack, bracing through rack plate, adjustment ring, etc.) to maintain relevant function. This function includes endurance of calculated reaction from analysis of piping system response due to ground movement.

5-Designing expansion connection for purposes other than ground displacement

Pipe support in designing expansion connection for purposes other than ground displacement must be deigned in such a way that displacement exceeding tolerance limit due to seismic movement is not applied on expansion connection or support has adequate strength to maintain function of connection displacement bracing member. This function involves endurance calculated reaction from analysis of piping system response due to ground movement.

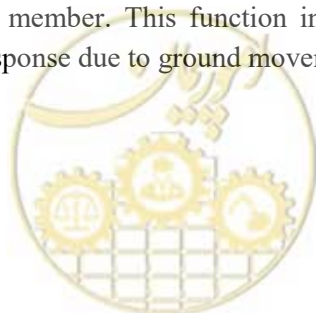

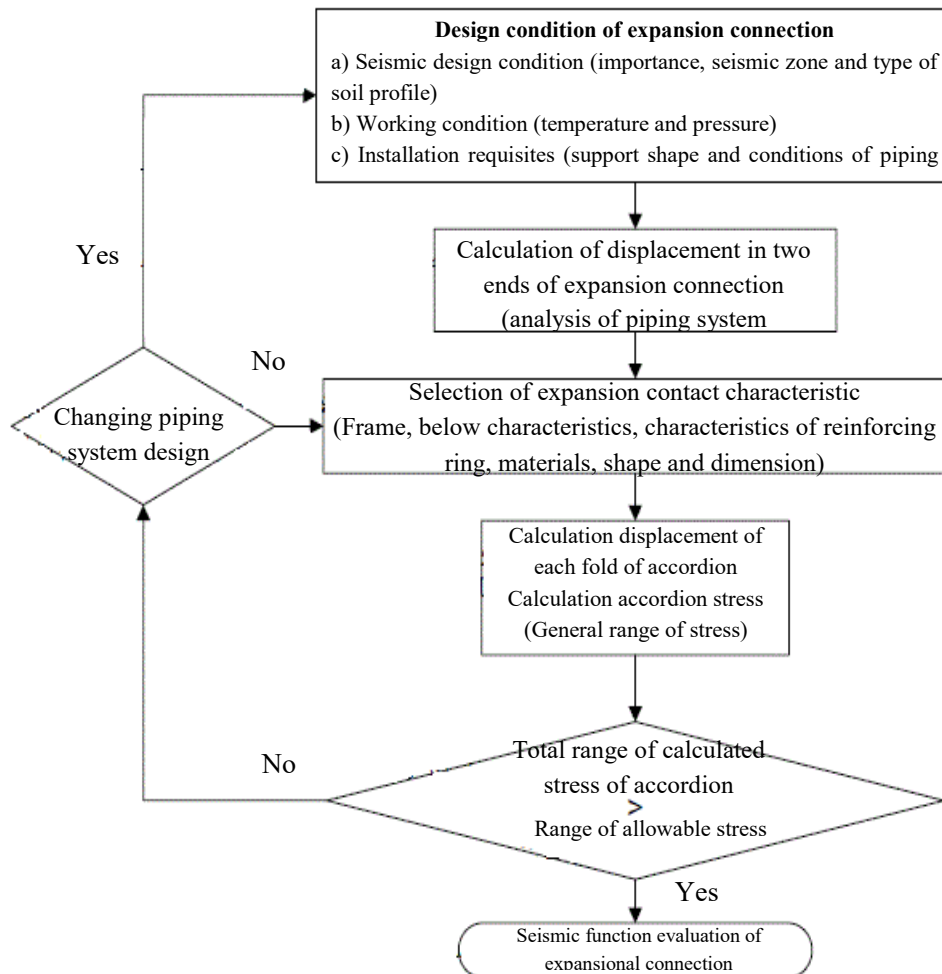

Figure 37-Flowchart of seismic function evaluation of expansional connection due to ground movement

21-Details of evaluation procedure of spray of containers and towers due to ground displacement

1-In seismic design, for displacement evaluation of pipe support point in spray of containers and towers due to ground displacement, sum of primary and secondary stress intensity resulted from related displacement must be lower than or equal to allowable stress intensity $4S_y$. In this case, separate evaluation with estimation of relevant inertia force is possible.

2-Evaluation spray of containers and towers using simplified method (the Bairard method) is performed on the basis of thin shell theory or analysis of finite element method (FEM) (and whatnot) and also according to section 5-3-9 in the subject of acceleration response analysis.

3-Figure 38, presents evaluation procedure of relative displacement of pipe support point in seismic function evaluation of spray of containers and towers due to ground displacement with simplified method based on the Bairard method. Also, in detailed analysis, evaluation is performed on the basis of similar method.

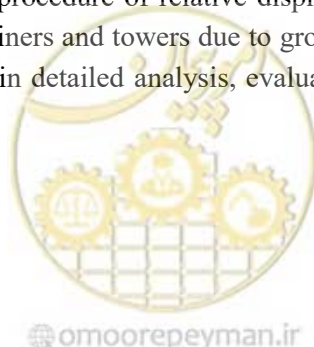

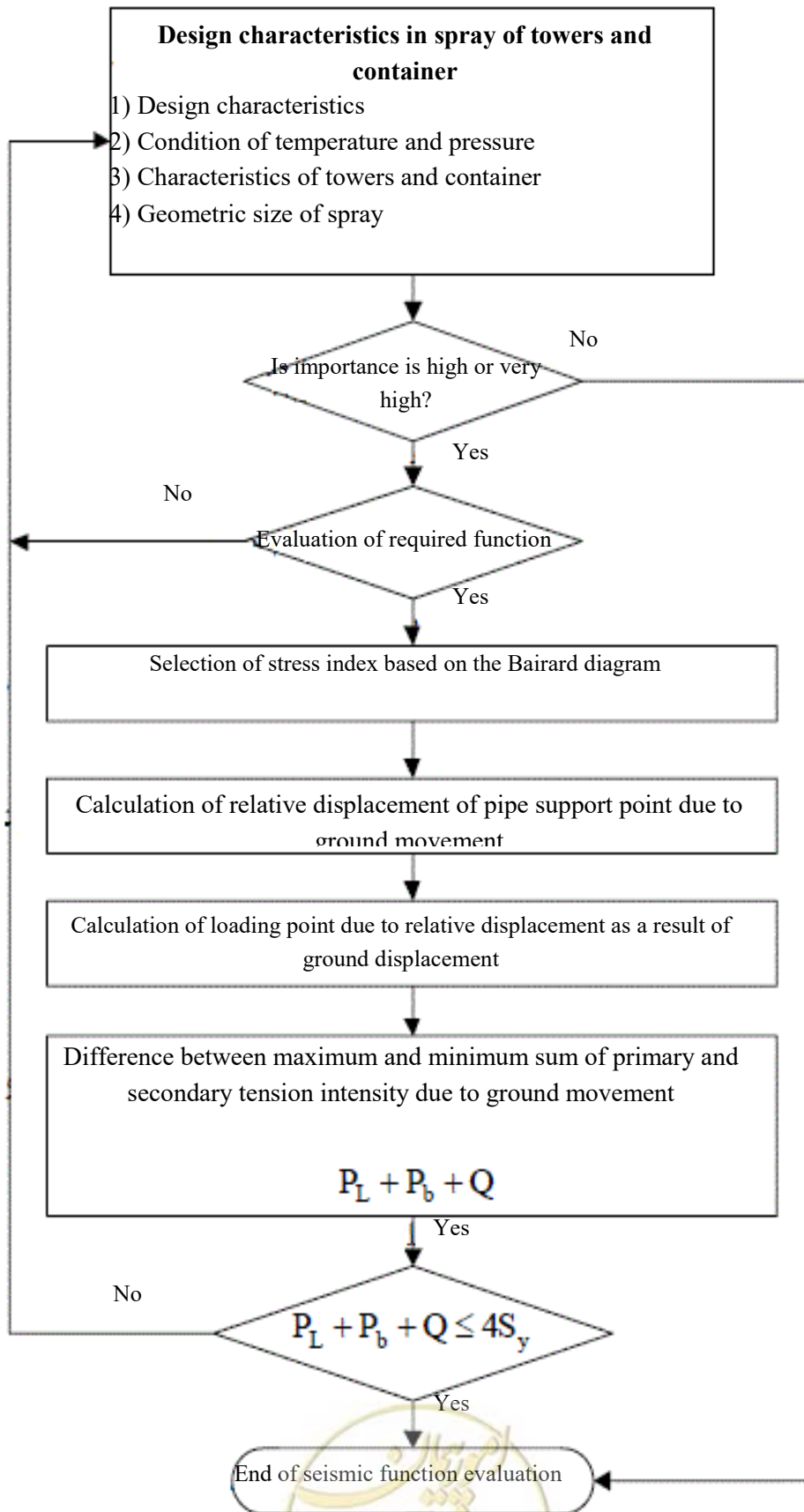

Figure 38- Seismic function evaluation of spray of towers due to ground movement

22-Seismic function evaluation of pipe support due to ground movement

1-Flowchart of procedure of seismic function evaluation of pipe support due to ground movement

Figure 39 shows pipe support evaluation flowchart due to ground movement.

1-1-Piping system evaluation due to ground movement is performed after confirmation acceptability of system evaluation against seismic inertia force.

1-2-Seismic function evaluation of piping system located on foundation due to ground movement is performed with determination of occurrence probability of liquefaction or ground displacement (ground movement)

1-3-If piping system together with seismic design equipment are founded on common foundation, it is required that fixation function of pipe support of equipment be performed in the nearest distance after seismic safety valve due to related ground displacement (ground movement).

1-4-If piping system together with seismic design equipments aren't founded on common foundation, it is required pipe support and its appurtenance have proper seismic function against relative ground displacement based on position of support point.

1-5- like evaluation of inertia force, seismic function of pipe support is evaluated through adjustment of allowable condition according to pipe support function.

2-Evaluationg seismic function of fixed pipe support

In the cases that ground displacement effects are predictable, piping system must be built on common (integrated) foundation.

In this case, first pipe support next to seismic safety valve in piping range is built on common foundation and support beyond system range is fixed.

On the other word, high deformation is occurring due to ground displacement in piping that is not located on common foundation. So it is required to be confirmed that piping located on common doesn't leak due to deformation resulted from deformation of pipe support that isn't located on common foundation. So with consideration the necessity for smallness of pipe fixed support deformation due to ground movement and endurance of reaction in three directions and bending moment surrounding three axis by piping, seismic function evaluation of pipe fixed support is done in such a way that produced stress due to reaction and moment resulted from ground displacement in piping must be lower than yield load.

In this case, piping reaction against ground displacement (and other things) is principally obtained from response analysis but it may be replaced by yield strength of total plastic moment of piping.

3-Seismic function evaluation of pipe reinforced support

Seismic function evaluation of pipe reinforced support against liquefaction due to ground displacement for non-occurrence of rupture is done in such a way that plastic deformation resulted from piping reaction in support must be lower than allowable plastic deformation.

4- Seismic function evaluation of free support

Free support is used to prevent from leakage in piping by reduction loading effects through separation of appurtenance seat of U-shaped bolt and removing support strength against

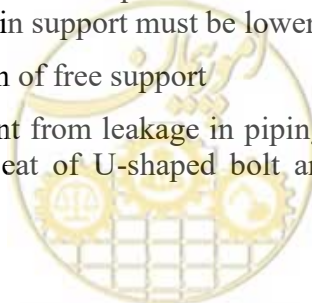

ground movement, provided that support function for inertia force due to ground movement is maintained. However, this support must be in such conditions that have loading condition characteristics of pipe support (and other things).

5-Adjustment allowable conditions

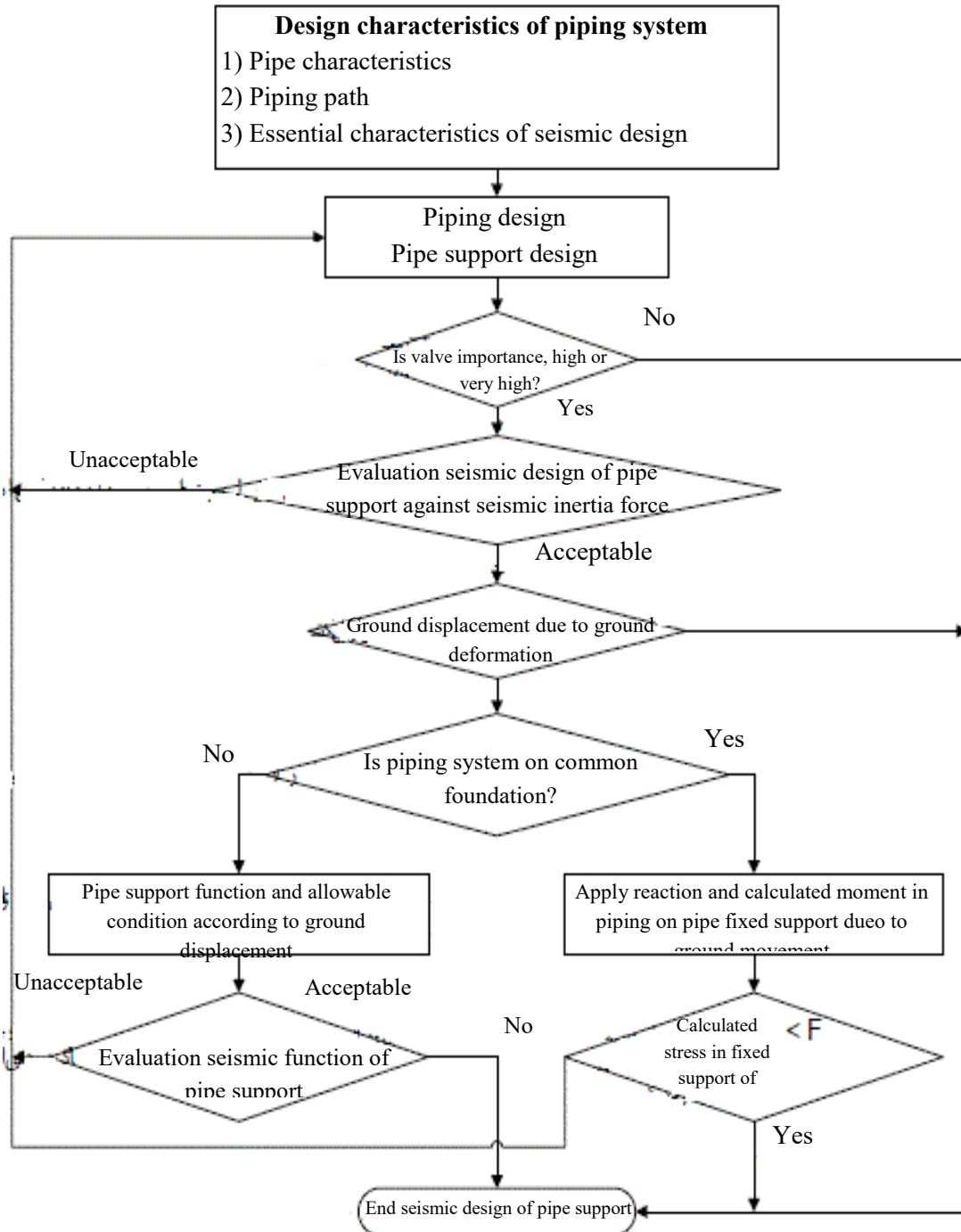

Figure 39-Flowchart of seismic design Evaluation of pipe support due to ground movement

