

Islamic Republic of Iran
Vice Presidency for Strategic Planning and Supervision

Loading and Seismic Analysis Guideline of Iran's Lifeline

No. 600

Office of Deputy for Strategic Supervision
Department of Technical Affairs

nezamfanni.ir

2012

Table Of Content	Page Number
Chapter 1- Generalities	
1-1-Introduction.....	3
1-2-Object of Instruction	3
1-3-Scope of Instruction	3
1-3-1- the structure of this Instruction	4
1-3-2- Notes on This Instruction	4
1-4-Main References	5
Chapter 2- Considerations for Loading and Seismic Design	
2-1-General Considerations for Loading and Seismic Design of Vital Arteries	9
2-1-1 Consideration for Installations	9
2-1-2- Considerations for Transmission lines	9
2-1-3- Considerations for Distribution and Collection Networks	10
2-2- Risk Levels of Earthquake	11
2-3- Loading and Seismic Analysis Methods.....	11
Software consideration:	17
Chapter 3 - Seismic Loads Generating Due to Wave Propagation	
3- SCM method	21
3-1-2- Importance Factor.....	21
3-1-3- Design Basis Acceleration Ratio	22
3-1-4 Magnification Factor of Soil Layers	22
3-1-5- Earthquake Factor.....	23
3-1-6- Design Horizontal Earthquake Force	23
3-1-7 -Modified SCM method.....	23
3-8-1- Modified Earthquake Force	26
3-2- Dynamical Methods	27
3-2-1- Response Spectrum Method.....	27



3-2-2- Time History Analysis Method27

3-3- Near Field (to fault) Coefficient31

Chapter 4- Seismic Load Due to Geotechnical Threats

4-2-Liquefaction.....35

4-2-1- Identification of a Region Susceptible to Liquefaction35

4-2-2- Liquefaction Evaluation37

4-2-2-2-Determination of Liquefaction Potential Index.....38

4-2-3-Ground Displacement Calculations39

4-2-4- Calculation of Lateral Pressure Due to Lateral Dispersion43

4-3- Ground Sliding44

4-3-1 evaluation of sliding due to permanent ground displacement44

4-3-2- Calculations of sliding due to permanent ground deformation45

4-4- Fault Displacement45

4-4-1- Evaluation of Active Fault46

4-4-2- Fault Displacement for Seismic Design46

4-4-3- Peak Strain at Fault Intersection.....46

Appendix 1- Computing Periods of Installations

1-Introduction.....51

2-Natural Vibration Period of Spherical Tanks51

3-Natural Vibration Period of Cylindrical Tanks53

4-Natural Vibration Period of the Framed Structures of Towers and Vessels53

4-1- the peak value of framed structure weight ratio is 0.1 and less54

4-1- the peak value of framed structure weight ratio is more than 0.154

Appendix 2- General Trend of Loading and Seismic Analysis of This Instruction



Definitions

Joint: a set of elements joining two members together

Seismic displacement response: the response of a system with one degree of freedom against sinus shakes with different frequencies.

Fault displacement: fault rupture on ground surface

Permanent displacement: irreversible (non-flexible) displacement of ground

Fault intersection: this term is usually employed when a pipeline crosses through a current fault

Equivalent allowable stress: a design method based on ductility design method reducing seismic intensity

Failure ultimate state: a situation at which a structure could be immediately used after MOE earthquake

Final ultimate state: a small physical damage which does not affect human lives, environment and stability of systems

Buried pipeline: a pipeline which is laid underground

Above ground pipeline: a pipeline which is laid above ground and is retained by supports.

Static method: a method for controlling seismic performances in the cases where earthquake force is applied to structure and ground by considering seismic coefficients as well as seismic strains due to earthquake.

Ductility design method: a design method in which material flexibility is considered

Arias intensity: the index of earth motion during earthquake (cm/s)

Flexibility: the ability of absorbing and damping energy and retaining the bearing capacity of structure in non-linear behavior state as well as the ability of absorbing displacement residue during earthquake.

Floating or uplift: uplift force generating due to differential pressure.

Conversion coefficient: the ratio of pipe structural strain to ground free strain

Behavior coefficient: a coefficient indicating combination of total ductility capacity and the extra resistance of a system which is resistant against lateral forces.

Design coefficient: (design factor): is a parameter which is used to categorize site specifications.

Liquefaction resistance factor: the ratio of dynamic shear strength to seismic shear stress.

Near-field factor: a factor employed in a design process in which the earthquake of near-field is taken into account.

Flexibility method based design: is a design method of structures in which inflexible performance of structures is taken into account.

Wave length: the distance of wave propagation within one cycle.

Target seismic performance: a performance level which is defined as design target.

Lateral dispersion: horizontal displacement of soil due to liquefaction and land slide.

Active fault: an active fault is a fault which has been active in recent 10000 years.

Sliding: physical sliding state of soils around pipe

Conduit: a big buried structure which is used for installing pipe structures.



Symbols

A_B : Brace cross section

A_{CL} : Bottom support cross section

$A_H(T)$: The acceleration of horizontal response in natural vibration period T

$A_V(T)$: The acceleration of vertical response in natural vibration period T

a_1 : The mean number of annual earthquakes which their magnitudes were ≥ 0

a, b : Fault model coefficients

b_1 : The relative likelihood of high intense and low intense earthquake.

C_1, C_2 : Correction factors of N in fine grains

C_3, C_4 : Bracing coefficients

C_h : Correction factor which depends on structure damping capacity

C_L : Correction factor of lateral displacement force in liquefied layer

C_{NL} : Correction factor of lateral displacement force in non liquefied layer

C_s : Correction factor of distance from water

c : Correction factor of position

c_w : Adjusting factor of earth movement during earthquake

D_0 : Inside diameter

D_B : The diameter of the circle drawn based on supports' centers

D_C : The outside diameter of upper support

D_S : The inside diameter of spherical tank

E : Modulus of elasticity

F_L : Liquefaction resistance parameter

F_{MH} : Modified horizontal seismic force

F_{MV} : Modified vertical seismic force

F_w : Deformation percentage

g : Acceleration of gravity

h : Height from ground surface

h_w : The depth of underground water (from water surface)

H : Thickness of surface layer

H_C : The height from the beneath surface of support plate to the centre of spherical body

H_i : Thickness of the i^{th} layer

H_L : Thickness of liquefied layer

H_{NL} : Thickness of non-liquefied layer

H_t : Height of framed structure

H_w : Height of shore structure (wharf)



- I_C : Momentum inertia of the lower support surface
- k_p : Passive earth pressure coefficient
- K : Horizontal rigidity
- K_1 : Rotational rigidity of whole body
- K_2 : shear rigidity of whole body
- K_H : Horizontal seismic intensity at ground surface
- K_{MH} : Modified horizontal seismic coefficient
- K_{MV} : Modified vertical seismic coefficient
- K_{SH} : Design horizontal earthquake coefficient
- K_v : Vertical seismic intensity at ground surface
- L : Seismic shear stress ratio
- L : Distance between adjacent supports
- L_A : Apparent wavelength
- L_a : Effective deformation length due to fault displacement
- L_{w0} : Length of lateral dispersed region
- L_{wp} : Distance between wharf and equipment
- M : Size of anchor based on design earthquake return period
- M : Earthquake magnitude
- MD : Peak ground displacement (PGD) at ground surface
- n_s : Number of supports
- N : The value obtained from standard permeability test
- N_a : Modified value of N which indicates the effect of grain size
- N_{bi} : Modified value of N which indicates the effect of grain size on the i^{th} liquefied layer
- N_{fa} : Site coefficient for short periods
- N_i : The value of N obtained from standard permeability test applied on the i^{th} liquefied layer
- N_1 : The value of equivalent N corresponds to the overburden effective pressure of 95KN/m^2
- N_v : Site coefficient for longer periods
- P_{ip} : Pile distance
- P_L : Psychological index
- q_L : Lateral displacement force per unit of region, applying on a structural member within a liquefied layer at depth x
- q_{NL} : Lateral displacement force per unit of region, applying on a structural member within a non-liquefied layer at depth x
- r_d : decrease rate of seismic shear stress ratio versus depth



R: distance from earthquake center

R_L : Tri-axial circular shear stress ratio

R_r : Dynamic shear strength ratio

S_v : Design velocity spectrum

$t_{1/3}$: Thickness of adjacent panel wall at the 1/3 of the height of adjacent panel

T: Natural vibration period of component

U_h : Ground horizontal displacement along pipe direction

$U_h(x)$: Horizontal displacement at depth x

V: Wave transferring velocity

V_{si} : Mean velocity of shear wave at the i^{th} layer

W_0 : Operational weight (N)

$W(x)$: Function of depth from surface

β_1 : Importance factor of component

β_2 : Design base acceleration

β_3 : Seismic reinforcement coefficient from bed rock to ground surface based on soil type and region factor

β_4 : Magnification factor of horizontal response

β_5 : Amplifying factor of horizontal response

β_{5n} : Standard amplifying factor of response

β_6 : Amplifying factor of vertical response

α_H : Horizontal acceleration at ground surface

α_v : Vertical acceleration at ground surface

α'_{HT} : Peak (Maximum) horizontal acceleration on bed rock

ε_G : Ground strain

σ_v : Total sum of the stresses of exterior materials

σ'_v : Effective stress of exterior materials

γ_{t1} : Specific weight of the soil above underground water surface

γ_{t2} : Specific weight of the soil beneath underground water surface

γ'_{t2} : Effective specific weight of the soil beneath underground water surface

δ_h : Ground horizontal displacement

σ_{vi} : Sum of the overburden pressures of the i^{th} liquefied layer

ΔN_{li} : Modified N which shows the effect of grain size on the i^{th} liquefied layer with respect to fine grains

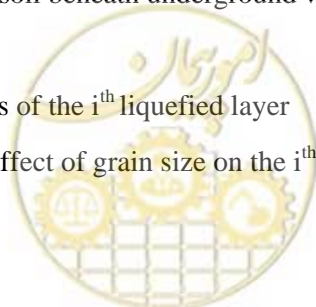

σ'_{vi} : Overburden effective pressure at the center of the i^{th} liquefied layer

θ_g : Slope angle of ground surface

γ_δ : Load factor

μ_i : Modulus of viscosity of the i^{th} liquefied layer

Δ_w : Wharf displacement

δ_h : Lateral dispersed region

γ_{NL} : Mean specific weight of non-liquefied layer

γ_L : Mean specific weight of liquefied layer

λ_M : Mean annual increase rate of earthquake magnitude M

β : Order of contact angle with fault with respect to pipe axis

θ_e : Diagonal brace angle with respect to horizon (degree)





Chapter 1

Generalities





1-1-Introduction

Vital arteries are called to a set of structures, installations and equipments which save, supply and distribute our critical requirements including water, power, and gas or acquire, save, treat and recover sewage and waste materials or make communications like phones and cells, internet and data. This instruction does not cover roads and bridges as they have been widely developed and have their own instructions and standards.

Since seismic engineering of vital arteries is a new emerged branch, even in developed countries like Japan and U.S, the vast majority of seismic design and improvement codes have not been standardized yet and they are being used as instructions. This instruction is prepared in Iran as the first basic step for preparing seismic design and improvement documents of vital arteries. Then, when experts and specialists get familiar with this by lapse of time, it would be used as a standard regulation in future.

This instruction has been prepared based on the similar documents prepared in developed countries as well as national experiences and experiences of some other foreign countries which are pioneer in seismic engineering. Although we have attempted to use the experiences of other countries we pay attention however to localization issues and we try to present more applicable and easy instruction.

1-2-Object of Instruction

The object of this instruction is to offer a framework for defining minimum seismic load as well as defining seismic analysis method aiming at seismic design of the components of vital arteries. Thus, the ultimate object of this instruction is to supply acceptable safety with respect to logical risks in terms of economic condition as well as the nature of earthquake and vulnerability of vital arteries installations.

1-3-Scope of Instruction

The scope of this instruction is various above ground and underground components of vital arteries in accordance with the classification presented in section 2. The structural components of vital arteries are divided into two main sections:

- stationary structures (the structures which are constructed in a fixed site)
- Line and network structures (structures with one long dimension which are constructed between stationary structures)

Stationary structures themselves are mainly constructed above ground, although in some cases they are underground structures while line and network structures are mainly buried underground structures and just in some cases they are above ground structures.

The response of ground acceleration to earthquake affect stationary structures due to their huge mass while line and network structures, which are buried in most cases, are affected by the response of ground velocity to earthquake and in some cases ground displacement.

Based on the experiences of past earthquakes, the increase of earthquake acceleration which was accompanied with more damages of stationary structures are proportional to structures' mass and in the case of low velocity, line and network structures i.e. pipelines and tunnels suffer low damages. Unlike buildings in which the mass of structure has been distributed almost uniform between flats in heights, the

stationary structures of vital arteries lack a uniform distribution of mass. Thus, the inertia force generated due to earthquake is applied on their mass center. This force is considered as the product of structure mass and modified acceleration (as earthquake factor).

Long line and network structures, both underground and above ground, are very sensitive to the generated displacement. The input relative displacement is converted to strains and stresses in this kind of structures.

In line and network structures the effect of inertia force is decreased as we move from above ground structures towards buried ones as the behavior of buried structures is practically under the influence of soil behavior and their mass is negligible compared with the mass of around soil.

The stationary structures consist of different indoor and outdoor installations. Outdoor structures themselves are constructed as underground and above ground structures.

Some special components of vital arteries have unique features distinguishing them from other components presented in this instruction. These exceptions will be presented in future revisions following necessary studies.

1-3-1- the structure of this Instruction

This instruction with the mentioned object and scope has been structured as follows:

Section 1: generalities

Section 2: loading and seismic loading considerations

Section 3: seismic load generating due to wave propagation

Section 4: seismic load generating due to geotechnical threats

Appendix 1: calculations of natural vibration period of installations

Appendix 2: general trend of loading and seismic analysis of this instruction

1-3-2- Notes on This Instruction

Since this is the first edition of Iranian instruction for seismic loading of vital arteries, undoubtedly it contains problems and ambiguities like any other instructions and regulations. In order to minimize and correct them it would be very beneficial to pay attention to the following notes:

- 1-It has been tried that the criteria of this instruction have no conflict with the standard 2800. In the case of incoherence the standard 2800 would be preferred.
- 2-In the case of shortage of information about the quality of loading of the members of target system, refer to the standard 2800 as well as section 6 of Iranian national building regulations.
- 3-The methods which have been referred in this instruction but have not been described in detail could be used in accordance with Iranian 2800 standard or any other valid regulations.
- 4-Similar instructions and documents which has been prepared by national and international authorizes, as a case standards for the seismic design of electrical installations, could be used provided that they are in accordance with this instruction.
- 5-To use this instruction more easily and more compatible with our requirements we expect all users to inform us their comments about improving and correcting this instruction. Editors will consider the comments in future versions.



1-4-Main References

In preparing this instruction various standards, regulations, instructions and codes have been used. The most important one are as follows:

- Standard 2800 of Iranian: Seismic design of buildings regulations; standard 2800, building and housing research center, 2005
- UBC97: Uniform Building Code, U.S.A, 1997
- ASCE7: Minimum design load for buildings and other structures, ASCE, 2006
- Eurocode 8: Designing earthquake-proof buildings; section 4: store-pits, tanks and pipelines; European Standard Committee, 2006
- BCJ1997: specifications for seismic design of building installations, Building Centre of Japan, 1997
- JWVA97: specifications for seismic design and construction of water supply installations, Japan Water Works Association, 1997
- Japan Gas Association: Instruction for seismic design of high pressure gas pipelines for liquefaction condition, JGA-207-01,2001
- High pressure gas safety institute of JAPAN (KHK): Seismic design of high pressure gas installations regulation, 2006





Chapter 2

Considerations for Loading and Seismic Design





2-1-General Considerations for Loading and Seismic Design of Vital Arteries

Considerations and rules of seismic loading of the stationary building structures are in accordance with the standard 2800.

In the cases where the standard 2800 gives insufficient information about building structures of vital arteries, other approved seismic loading codes could be used. In other stationary structures related design codes of vital artery would be applicable.

2-1-1 Consideration for Installations

- Architecture and configuration of these structures are defined based on their performance and different factors like irregularities, variations of mass and stiffness, internal pressures, properties of chemical and industrial substances inside them and process temperature should be accurately considered.
- Geotechnical considerations of these structures follow similar considerations described in the standard 2800.
- A building which protects installation structures inside itself is considered as a building structure.
- Generally, installation structures consist of three main sections: body, base and foundation. In some structures however, the body of structure may have no base and it may be mounted directly on the foundation.
- Since the body of installation structures are seismic designed in accordance with their related standards and codes, the focus of seismic loading considerations in this instruction is on the base and foundation of these structures.
- Strength and stiffness of bases as well as their resistance against sliding and overturn are considered as the most important topics of seismic design and study.
- Appropriate joint between body and base as well as base and foundation should be established. Also, proper compatibility with seismic behavior is necessary.
- Compatible joint between these structures and adjacent or fixed structures is necessary so that they could easily bear both ends relative displacements.
- It is preferred that these structures be connected to pipes, tunnels, valves and etc through joints with required flexibility. This flexibility could be obtained by several methods like appropriate geometrical shapes as U or Z shaped joints, expansion joints, hose joints and other similar joints.
- In the case of high pressure or temperature, it is advised that the flexibility be obtained by flexible shaped adaptor pipes unless operational process doesn't allow this. In such conditions other methods could be used.

2-1-2- Considerations for Transmission lines

- Transmission lines are divided into two underground and above ground categories. Generally, pipes belonging to transferring lines have higher diameters.
- It is preferred that the lines be laid as buried lines. In some sections however, they could be implemented above ground if necessary.
- Generally, cable lines (electric and communication lines) show better seismic behavior if they are implemented underground.

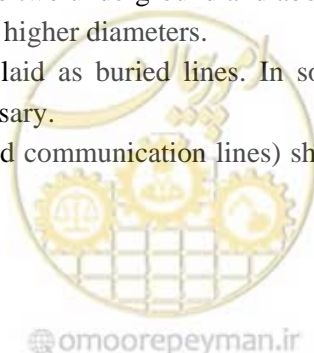

- The behavior of the underground lines crossing through conduits would be the same as that of conduits.
- These lines should be inspected after earthquakes and displacements generating due to geotechnical threats.
- Preventive measures should be prepared wherever the lines cross through faults in order to minimize the effect of fault displacement on pipes or tunnels.
- Based on our experiments from the seismic behavior of past earthquakes, use of brittle materials in transmission lines is not recommended. Steel and poly ethylene pipes show acceptable seismic behavior.
- Use of cast iron, asbestos and ceramic pipes in transmission lines is not recommended.
- Concrete pipes, plastic pipes (like PVC) and GRP could be employed based on the permission of consultant engineers and acceptance of employer.
- Continuous steep pipes should be joined using penetrative welding and the accuracy of welding should be assured.
- Poly ethylene pipes with butt fusion and electro fusion penetration joints are applicable.
- Complete penetration of weld should be assured.
- In the case of pipes with mechanical joints, anti-earthquake joints should be used.
- In large transmission conduits concrete tunnels, coated tunnels and high diameter pipes show more safe seismic behavior at deeper depths.
- The capability of absorbing relative displacement at the join point of transmission lines and building or installation structures should be supplied.
- In sharp steep grounds (more than 60%) in which the occurrence of sliding phenomenon is probable, necessary measures should be prepared in order to have acceptable performance and see no leakage of pipe lines.
- In the grounds which are susceptible to liquefaction phenomenon, in addition to the investigation of seismic resistance of transmission lines, necessary provisions should be taken in order to reinforce ground, to make drainages and to do similar activities.

2-1-3- Considerations for Distribution and Collection Networks

- Distribution and collection networks of vital arteries systems including pipe and cable are generally buried. The diameters of network pipes are lower compared with that of transmission line pipes.
- In designing and seismic investigation of these lines, their interactions with other adjacent buried lines should be taken into account.
- Joints of distribution and collection pipes including pipe and cable should be anti-seismic joints.
- Steel and poly ethylene pipes of distribution network should have penetrated weld joints.
- Only ductile cast iron pipes with anti-seismic mechanical joint are applicable in the networks.
- In the intersection point of the lines and manholes, buildings' hand holes, installation structures and similar situations, it is essential to use joint which are capable to absorb relative displacement in joining point.
- Implementing pipe or cable distribution network inside common channels and conduits is acceptable provided that technical and safety standards be considered.

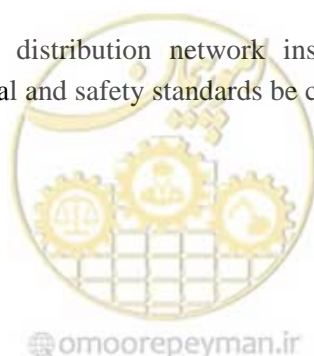

2-2- Risk Levels of Earthquake

Two risk levels should be considered for the seismic design of vital arteries as follows:

- Risk level 1: is a level which is considered for serviceability earthquake level and damage limit state with continuous operational performance
- Risk level 2: is a level which is considered for ultimate limit state with minimum interval operational performance.

Risk level 1: serviceability level may occur one or two times during service period. In this case no damage should occur to members in order to enable system to operate safely and continuously. In this level, the occurrence probability is 50% within a 50 years period and a 75 years return period (recurrence interval).

Risk level 2: the probability of occurrence of this earthquake is lower and it has higher return period (recurrence interval) compared with serviceability earthquake. In this case system is designed based on ultimate limit state. In this case the system should experience no huge damages and it could retain its stability so that it should be capable to restart its operations after emergency repairs with minimum interval. In this level, the occurrence probability is 10% within a 50 years period and a 475 years return period (recurrence interval).

2-3- Loading and Seismic Analysis Methods

The following analytical methods are used for seismic investigation of systems:

- Semi static (pseudo static) method: it is an equivalent static analysis for calculating earthquake force generating due to members' mass inertia.
- Dynamic method (spectral or time history)

Generally, above ground stationary structures are seismic analyzed using semi static method.

Buried structures are seismic analyzed through both semi static and dynamic methods.

Structures with sophisticated behavior or special conditions are seismic analyzed using dynamic method.

Since network systems consist of different structures and the structures themselves are placed on different soil types, we cannot apply the same seismic calculation on all types of installations.

Analysis method is selected based on the characteristics of target structure.

The following items affect structure vibration as well as earthquake force:

- the specifications of input quake
- the specifications of site
- structure's mass, damping rate and stiffness

Tables 2-1 to 2-6 show proposed methods for main vital arteries for both risk levels. You may see that some components have not been described in the tables. They will be added in next revisions.

In these tables we have:

SCM: Seismic Coefficient Method (quake factor method)

We use this method to compute the inertia force generating due to earthquake acceleration applying on masses. No buried components or buried components with heavy weights which are capable to vibrate are apparent instances of employing this method. This method will be described in detail in next sections.

RDM: Response Displacement Method



We use this method to calculate the force of ground and buried members interaction based on the theory of "beam on elastic bed" as well as "elasticity between soil and buried member". Calculating the force applying from ground to pipes, tunnels and buried shafts are apparent examples of employing this method. This method will be described in detail in next sections.

DAM: Dynamic Analysis Method

This method is applicable in all above ground and underground components as well as in analyzing all earthquake effects on members. Modeling through this method is more sophisticated than two other mentioned methods. Selection dynamic parameters specially damping ratio as well as finding appropriate accelerometer and the quality of applying permanent displacement are considered as the difficulties of this method. According to the measures presented in this instruction, for complex and unknown installations, only this method must be employed. It will be described in detail in next sections. Generally it follows the clauses of the standard 2800.



Table 2-1: seismic calculation of water supply system's components

Seismic calculating method		Type of structure	
Risk level 2	Risk level 1		
And DAM if necessary SCM	SCM	Water inlet line	
And DAM if necessary SCM	SCM	Water inlet gate	
And DAM if necessary SCM	SCM	Water inlet tower	
RDM	RDM	Crossover	Water inlet pipe/treatment gallery
RDM	RDM	Collinear	
RDM	RDM	Low deep well	
RDM	RDM	Deep well	
RDM	RDM	Crossover	Open channel with drainage
And DAM if necessary RDM	RDM	Collinear	
RDM	RDM	Crossover	Water transmission/delivery and distribution tunnels
And DAM if necessary RDM	RDM	Collinear	
And DAM if necessary SCM	SCM	the bridge for transmission of water pipeline (pipe bridge)	
-	-	Crossover	Underground water pipeline
And DAM if necessary SCM	RDM	Collinear	
SCM or RDM	SCM or RDM	Reserve pipeline installations	
SCM or RDM and DAM if necessary	SCM or RDM	Protected vertical shaft	
SCM or RDM and DAM if necessary	SCM or RDM	Buried tank	
DAM	SCM for non-buried section as well as buried section with vibrating mass + RDM for buried section	Half-buried tank	
SCM and DAM if necessary	SCM or DAM	Water service tank/high water tank	
SCM	SCM	Electrical and mechanical installations	
SCM	SCM	Special building structures of system	

Table 2-2: seismic calculation methods for sewage system's components

Seismic calculation method	structure	
RDM	Sewage conduits (pipe and network)	
SCM	Reservoir structure	Treatment and pumping stations
RDM	Linear underground structure	
SCM	Plate shaped structure	
SCM	A combination of building, pool or tank	
Depends on building specifications	Building structure	

Table 2-3: seismic calculation methods for gas supply system's components

Seismic calculation method	structure	
SCM, RDM and DAM if necessary	Piping and pipe retainer (support) (diameter higher than 45mm)	Refinery installations
SCM and DAM if necessary	Case (lateral and vertical)	
SCM and DAM if necessary	Tower (height more than 5 m)	
SCM and DAM if necessary	Spherical tank (capacity: more than 3 tons or higher than 300m ³)	
SCM and DAM if necessary	cylindrical tank with high dimensions (reserve tank, foundation of tank's related installations and so on) (capacity: more than 3 tons or higher than 300m ³)	
SCM and DAM if necessary	regulator	
SCM, RDM and DAM if necessary	High pressure valves, joints and etc	
SCM and time history analysis if necessary	Foundation of installations	
SCM and DAM if necessary	Semi building structures	
Modal analysis	Pipe stations and pressure relief valve	
SCM and DAM	Surface mounted lines	
RDM and FEM if necessary	Buried lines	
SCM	Electrical and mechanical installations	



Table 2-4: seismic calculation methods for power supply system's components

Seismic calculation method	structure		
SCM	Main body of boiler	Boiler and peripherals	Power plant
SCM (modified) and DAM if necessary	Support frame of boiler		
SCM	Boiler's main peripherals		
SCM	Exhaust gas/inlet air conduit-outlet gas treatment installations		
SCM and DAM if necessary	Vapor turbine and peripherals		
SCM (modified) and RDM for underground pipes	Fuel combustion installations (oil)		
SCM (modified) and DAM if necessary	Fuel combustion installations (LNG)		
SCM and DAM if necessary	Chimney		
SCM (modified)	Control unit		
SCM (modified) and RDM and DAM if necessary	Piping systems		
SCM and time history analysis if necessary	Foundation of installations/Foundation of tanks		
SCM	Transformer		Transmission post
DAM	Insulator		
DAM	Bushing		
SCM and RDM	Cable		
SCM	Other equipment		
SCM and RDM (for mast foundation) and DAM if necessary	Transferring line (masts and brackets)		Transferring and distribution installations
SCM	Distribution line (spatial structures of distribution lines)		
SCM	Electrical and mechanical installations		



Table 2-5 seismic calculation methods for communication system's components

Seismic calculation method		structure			
Risk level- 2	Risk level- 1				
SCM , RDM and DAM if necessary		Communication lines metal masts			Transmission installations
SCM (Modified) and DAM if necessary		Wireless communications metal masts			
SCM		brackets			
SCM		Spatial equipments			
SCM and DAM if necessary	SCM	above ground pipe		above ground conduit	Conduit for transmission cable lines
SCM	SCM	Transverse direction	Pipe joined to bridge		
-	-	Longitudinal direction			
SCM , RDM and DAM if necessary	SCM or DAM	Concrete covering and vertical shaft			
RDM	RDM	Transverse direction	tunnel	Buried conduit	
RDM and DAM if necessary	RDM	Longitudinal direction			
RDM	RDM	Transverse direction	culvert		
RDM and DAM if necessary	RDM	Longitudinal direction			
SCM , RDM and DAM if necessary		shaft, saving cover and cable conduits			
SCM and RDM		manhole			
SCM		Electrical and mechanical installations			



Table 2-6 seismic calculation methods for vital arteries

Seismic calculation method		structure		
Risk level- 2	Risk level- 1			
RDM	RDM	Transverse direction	tunnel	Buried conduit
RDM and DAM if necessary	RDM	Longitudinal direction		
RDM	RDM	Transverse direction	culvert	
RDM and DAM if necessary	RDM	Longitudinal direction		
SCM and DAM if necessary	SCM	above ground pipe		Above ground conduit
SCM	SCM	SCM	Pipe joined to bridge	
-	-	Longitudinal direction		
SCM or RDM and DAM if necessary	SCM or RDM	Concrete covering and vertical shaft		

The characteristics of earthquake loads are defined based on the selected method

Software consideration:

In order to conduct the above analysis we can use various available soft wares. For example: ABAQUS and ANSYS could be used for all methods

In order to analyze pipes we can use special soft wares like ERAUL and PIPE

In order to analyze tanks we can use TANK and PV-Elite soft wares.





Chapter 3

Seismic Loads Generating Due to Wave Propagation





3- SCM method

SCM method is categorized to the following classification based on the categorizes of the structural members of vital arteries systems and earthquake risk levels:

1-earthquake factor of risk level 1

2-earthquake factor of risk level 2

- in both mentioned categorizes earthquake factors are defined as horizontal and vertical earthquake factors.
- Calculation equations of SCM method is related to horizontal earthquake factor
- The earthquake force applying on each member is defined as the product of earthquake factor and effective weight of the member. This force is applied on the mass center of the related structural member.

Horizontal earthquake factor is obtained from continuous multiplying of the following seismic parameters:

- importance factor
- design acceleration ratio
- magnification factor of soil shake on bedrock

3-1-1 Seismic Intensity

Earthquake acceleration rate up to soil surface or bed rock is called shake intensity (in surface or rock). It corresponds to earth maximum acceleration rate based on design basis earthquake and is calculated as follows:

a) horizontal seismic intensity at ground surface:

$$K_H = 0.3 \cdot \beta_0 \cdot \beta_1 \cdot \beta_2 \cdot \beta_3 \quad (3-1)$$

b) vertical seismic intensity at ground surface:

$$K_V = \frac{K_H}{2} \quad (3-2)$$

In which

K_H : Horizontal seismic intensity at ground surface

K_V : Vertical seismic intensity at ground surface

β_0 : Earthquake level parameter. For risk levels 1 and 2 it is respectively 0.5 and 1.

β_1 : Importance factor

β_2 : Design basis acceleration ratio

β_3 : Seismic amplification factor (from bed rock to ground surface) with respect to soil type

3-1-2- Importance Factor

Importance levels are defined as follows:

Very high: components which their damages would result in generating and spread of critical conditions as well as casualties and extensive property damages.

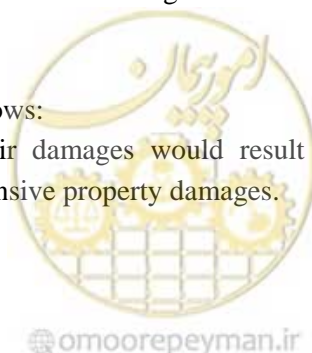

High: components which their damages will result in rupture of flow and services and property damages

Moderate: components which their damages will result in flow disorders.

Low: components which their damages don't affect system's performance.

The importance factor of a structure is defined based on its importance and is shown as β_1 . It is selected from table 3-1 based on employer opinion.

Table 3-1: Importance Factor β_1

low	moderate	high	Very high	Importance group
0.8	1	1.2	1.4	β_1

3-1-3- Design Basis Acceleration Ratio

Design basis acceleration ratio, β_2 is defined from table 3-2 based on the category of site which has been presented in the standard 2800.

Table 3-2: design basis acceleration ratio β_2

4 low	3 moderate	2 intensive	1 Very intensive	seismicity condition
0.20	0.25	0.30	0.35	β_2

3-1-4 Magnification Factor of Soil Layers

The magnitude of earthquake force applying on structure depends on the magnification factor of site's soil layers (from bedrock to ground surface).

Magnification factor versus soil layers is defined as magnification factor of β_3 .

Table 3-3 shows magnification factors of different ground types.



Table 3-3 magnification factor of site β_3

Type 4	Type 3	Type 2	Type 1	Soil type Design basis acceleration ratio
2.25	1.75	1.5	1.5	low
2.25	1.75	1.5	1.5	moderate
1.75	1.75	1.5	1.5	intensive
1.75	1.75	1.5	1.5	Very intensive

3-1-5- Earthquake Factor

Following calculating seismic intensity of two risk levels, we calculate earthquake factor in order to obtain earthquake load applying on different components.

Regarding soil type as well as the basic period of the under loading component, in the following conditions SCM method is employed:

- In the soil type 1 provided that the basic period of the under loading component is ≤ 0.5 s.
- In the soil types 2 and 3 provided that the basic period of the under loading component is ≤ 1 s.
- In soil type 4 provided that the basic period of the under loading component is ≤ 1.5 s.

Unless the above mentioned cases, you could use 3-1-7 and 3-2 clauses.

Design horizontal earthquake factor is derived from relation (3-3):

$$K_{SH} = \beta_4 K_H \geq 0.2 \quad (3-3)$$

In which;

K_{SH} : is design horizontal earthquake factor (structure's frequency response is taken into account)

β_4 : is the magnification factor of horizontal response. The magnitude of this factor depends on the height of structure from ground surface as follows:

- If the height is ≤ 16 m this factor is 1
- in the case of $16\text{m} < h < 35\text{m}$ it is $0.0125h + 0.8$
- If the height is above 35m this factor is 1.2375 (in the cases where the height is above 35m, in order to use SCM method, period should be under control.)

h : is the height from ground surface (m)

3-1-6- Design Horizontal Earthquake Force

Design horizontal earthquake force, F_{SH} (equivalent static force) is derived from relation (3-4):

$$F_{SH} = K_{SH} W_H \quad (3-4)$$

In which;

F_{SH} : is design horizontal earthquake force (N)

W_H : is structure weight + live and dead load weights (N)

3-1-7 -Modified SCM method

In the case of structures with moderate and low importance factors which their natural periods are higher than magnitudes presented in the clause 3-1-5, modified SCM method could be used

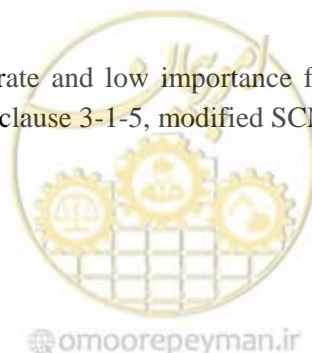

Following calculating earthquake factor through modified SCM method, we should multiply the obtained value and the weight of the given structure (equipment) in order to calculate horizontal or vertical earthquake forces.

Modified earthquake factors in both horizontal and vertical directions are obtained based on horizontal and vertical seismic intensities as follows:

$$K_{MH} = \beta_5 K_H \quad (3-5)$$

$$K_{MV} = \beta_6 K_V \quad (3-6)$$

In which;

K_{MH} : is horizontal modified earthquake factor

K_{MV} : is vertical modified earthquake factor

β_5 : is response amplification which is derived from relation (3-7):

$$\beta_5 = \beta_{5n} C_h \quad (3-7)$$

In which;

β_{5n} : is standard response amplification shown in Fig. 3-1

C_h : is modification factor with respect to structure damping rate shown in Fig. 3-2

β_6 : is vertical response amplification which is determined as follows:

- for equipment towers with skirt base it is 1.5
- for other installations, it is 2.0

Evaluation of vertical design earthquake in the components with moderate and low importance factors is not necessary.

Unless towers with skirt base in which the ratio of mean diameter (D_m) to height (H) from base plate is less than 4.0, the magnification factor of horizontal response, β_5 could be considered 2.0 with no calculation



Table 3-4: damping rate of towers, spherical tanks and frames

Damping ratio	Installation		
0.03	T < 1.0s		Tower and vertical case
0.07 – 0.04T	1.0s < T < 1.5s		
0.01	1.5s < T		
0.03	Welded brace		Spherical tank
0.05	Screwed brace (pin joint)		
0.07	Horizontal cylindrical tank		
0.05	Structure with constraint	Steel structure	frame
0.03	Structure without constraint		
0.05	frame	Reinforced concrete structure or concrete with steel frame	
0.10	A structure constrained with a lot of number of walls		

The method of calculating the natural period, T, of all mentioned structures has been presented in this instruction.

The 2800 standard is also applicable for calculating natural period of some installations.

Table 3-5 damping ratio of cylindrical tank

Damping constant			Type of cylindrical tank		
0.05			above ground tank type 1 or $H_L / D_0 > 1$		
≥ 40	From 20 up to 40	<20	D_0 P_{ip}	With pile	Unless upper column
0.10	0.10	0.08	<1.5		
0.10	0.08	0.07	From 1.5 up to 3.0		
0.08	0.07	0.05	≥ 3.0		
0.10	0.07	0.05	Without pile		

In the table 3-5 symbols H_L , D_0 and P_{ip} stand for the following items:

H_L : is the highest height from fluid surface (m)

D_0 : is inside diameter (m)

P_{ip} : is distance from pile (m)



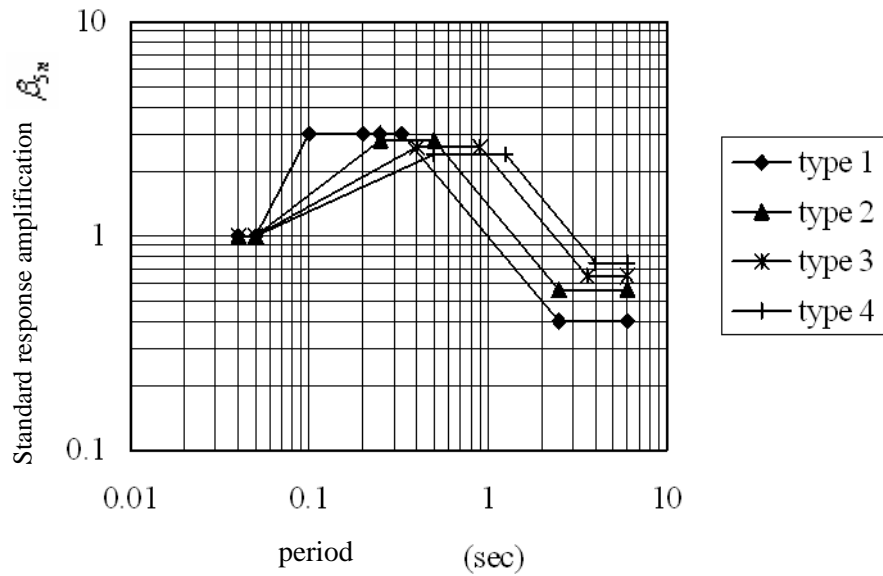

Fig. 3-1 β_{5n} : standard response amplification

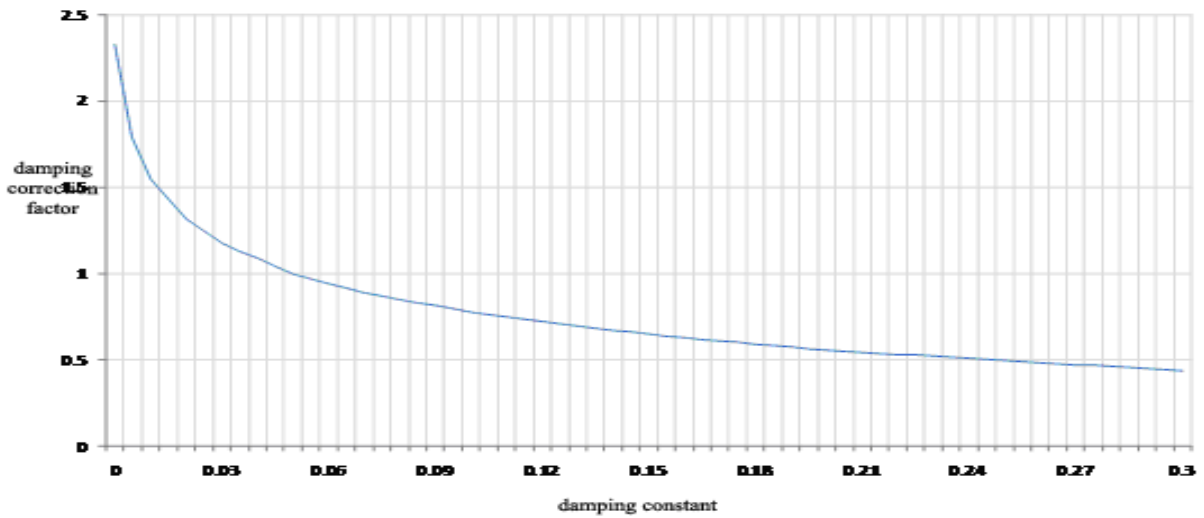

Fig. 3-2 C_h : damping correction factor

3-8-1- Modified Earthquake Force

Modified earthquake force is obtained by multiplying modified earthquake factor and structure's weight and relations (3-8) and (3-9):

$$F_{MH} = K_{MH} \times W_H \tag{3-8}$$

$$F_{MV} = K_{MV} \times W_H \tag{3-9}$$

In which;

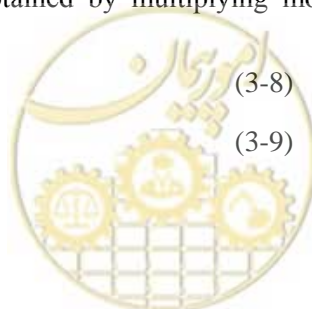

K_{MH} : is modified horizontal earthquake factor (which is derived using the relation (3-5))

F_{MH} and F_{MV} : are respectively horizontal and vertical modified earthquake forces (N)

W_H : is structure's weight + weights of live and dead loads (N)

3-2- Dynamical Methods

Sophisticated structures as well as structures with very high and high importance factors are analyzed using methods which will be described next. Applying the methods of the standard 2800 instead of our method is permitted.

3-2-1- Response Spectrum Method

Horizontal response acceleration for each $A_H(T)$ mode is derived from relation (3-10):

$$A_H(T) = \beta_5 \cdot \alpha_H \quad (3-10)$$

In which;

$A_H(T)$: is horizontal response acceleration at natural period T (cm/s^2)

β_5 : is the magnification factor of horizontal response (it is considered 1.5 and 0.75 respectively for the periods below 0.3 second and above 0.3 second)

α_H : is horizontal acceleration at ground surface (cm/s^2) which is derived from relation (3-11):

$$\alpha_H = 700 \cdot \beta_1 \cdot \beta_2 \cdot \beta_3 \quad (3-11)$$

Vertical response acceleration for each $A_V(T)$ mode is derived from relation (3-12):

$$A_V(T) = \beta_6 \cdot \alpha_V \quad (3-12)$$

In which;

$A_V(T)$: is vertical response acceleration at natural period (T) (cm/s^2)

β_6 : is the magnification factor of vertical response (it is 1.5 in towers with skirt base and 2 in other structures)

α_V : is vertical acceleration at ground surface which is derived from relation (3-13):

$$\alpha_V = 350 \cdot \beta_1 \cdot \beta_2 \cdot \beta_3 \quad (3-13)$$

Combining the results of modes as well as spectral analysis is carried out in accordance with the measures presented in the standard 2800.

3-2-2- Time History Analysis Method

In time history analysis method we should select such appropriate accelerogram which its maximum horizontal acceleration (with respect to site) is derived from one of the following methods:

1-in the case of use of bedrock records:

$$\alpha'_{HT} = 700 \cdot \beta_1 \cdot \beta_2 \quad (3-14)$$

In which α'_{HT} is the maximum horizontal acceleration on bedrock (cm/s^2)

2-in the case of use of ground surface records:



$$\alpha'_H = \alpha_H = 700 \cdot \beta_1 \cdot \beta_2 \cdot \beta_3 \quad (3-15)$$

In which;

α_H : is the maximum horizontal acceleration at ground surface based on spectral analysis (cm/s^2)

α'_H : is the maximum horizontal acceleration at ground surface based on time history analysis (cm/s^2)

Other requirements of seismic loading would be in accordance with the standard 2800.

3-2-2- Displacement Response Method for Buried Components

Applying displacement response method and considering the first shear vibration mode of soil will give us the displacement amplitude of soil of the locations of buried structures like pipes, tunnels, shafts and wells. This method is classified as follows with respect to earthquake risk levels:

- displacement response of the risk level 1
- displacement response of the risk level 2

For both mentioned cases, horizontal displacement amplitude is calculated and vertical displacement amplitude is considered as half of it. In this method, the amount of soil displacement amplitude depends on the following items:

- velocity response spectrum
- the natural period of the site of buried conduit
- horizontal earthquake factor
- the thickness of surface layer (soil layer on seismic bedrock)
- the burying depth from conduit center up to its center

Ground displacement amplitude at the depth of x from ground surface is derived from relation (3-16):

$$U_h(x) = \frac{2}{\pi^2} S_v T_G \cos \frac{\pi x}{2H} \quad (3-16)$$

In which;

$U_h(x)$: is horizontal displacement at depth x (cm)

H : is the thickness of surface layer (cm)

S_v : is design velocity spectrum (cm/s)

- It is extracted from Fig. 3-3 for the risk level 1
- It is extracted from Fig. 3-4 for the risk level 2



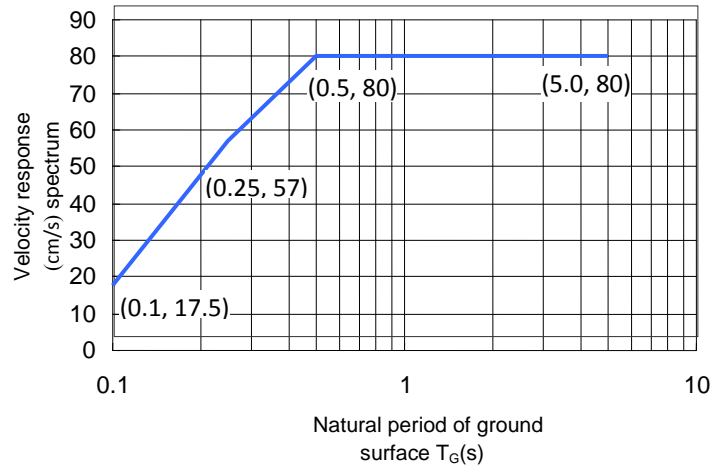

Fig. 3-3 velocity response spectrum for the risk level 1

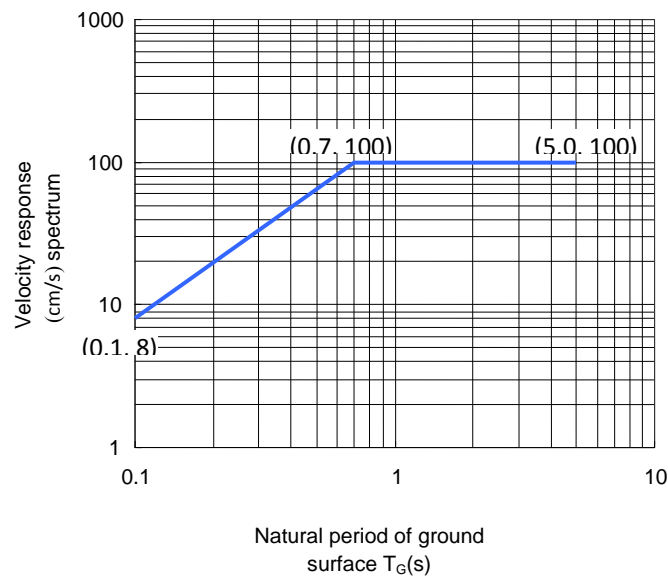

Fig. 3-4 velocity response spectrum for the risk level 2

T_G : is the ground dominant period (s) which is derived from relation 3-17:

$$T_G = 4 \sum_{i=1}^n \frac{H_i}{V_{si}} \quad (3-17)$$

In which;

H_i : is the thickness of the i^{th} layer (m)

V_{si} : is the velocity of mean shear wave at the i^{th} layer (m/s)



Ground surface period should be derived from relation (3-18):

$$T_p = \frac{H_h}{V_s} \quad , \quad V_s = \frac{\sum V_{si} \cdot H_i}{H_h} \quad (3-18)$$

In which;

T_p : is ground dominant period

H_h : is the thickness of ground surface (m)

H_i : is the thickness of the i th layer

V_s : is the velocity of mean shear wave of ground surface (m/s)

V_{si} : is the velocity of shear wave at the i^{th} layer (m/s)

The velocity of shear wave at each layer could be derived from the following relation:

$$V_{si} = C \cdot V_{si}^{\text{test}} \quad (3-19)$$

In which V_{si}^{test} is the result of elastic wave propagation test.

The value of C is 0.85 and 0.6 in clay and sand, respectively.

In sand ground we have:

$$V_{si} = 62N^{0.21} \quad (3-20)$$

In clay ground we have:

$$V_{si} = 122 \cdot N^{0.073} \quad (3-21)$$

And N is the value obtained from standard penetration test. (SPT)

The displacement employed in design process is derived as relation (3-22):

$$U_h = 0.8 \cdot \beta_1 \cdot \beta_2 \cdot U_h(x) \quad (3-22)$$

In displacement response method ground strain along pipeline direction is:

$$\varepsilon_G = \frac{\pi U_h}{L_A} \quad (3-23)$$

In which;

ε_G : is ground strain

U_h : is ground horizontal displacement along pipe direction (cm)

L_A : is apparent wavelength (cm)

Based on the Reyleigh model of surface wave in horizontal wave the apparent wavelength is:

$$L_A = V \cdot T_G \quad (3-24)$$

In which V is wave transmission speed in accordance with Fig. 3-5.



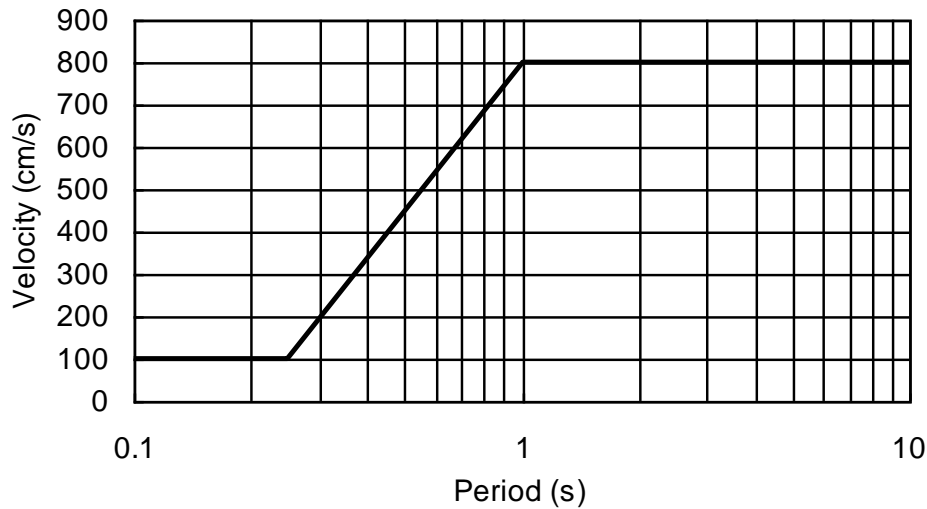

Fig. 3-5 relation between wave apparent speed and soil natural period

3-3- Near Field (to fault) Coefficient

Since the influence of near field is very important only in intensive earthquakes, the field coefficients of N_{fa} and N_v should only be applied in the seismic field of 1.

Two field coefficients should be applied for the results of ground movements with high amplitudes in long periods compared with short periods:

The field coefficient of N_{fa} is applicable only for controlling the spectrum of design acceleration response while the field coefficient of N_v is used for controlling the spectrum of design velocity response.

The value of N_{fa} and N_v ranges respectively from 1 to 1.5 and 1 to 2 depending on relative location of active faults as well as filed seismicity.

Table 3-6 shows N_{fa} coefficient for short periods versus three seismic sources and table 3-7 shows N_v coefficient for long periods versus different seismic sources.

Table 3-6 filed coefficients for short periods

The nearest distance from a given seismic source			Seismic source type
10 km	5 km	2 km	
1	1.2	1.5	A
1	1	1.3	B
1	1	1	C



Table 3-7 field coefficients for long periods

The nearest distance from a given seismic source				Type of seismic source (fault)
15 km	10 km	5 km	2 km	
1	1.2	1.6	2	A
1	1	1.2	1.6	B
1	1	1	1	C

The nearest distance from seismic source is the shortest distance between site and the filed which is defined by source vertical view on ground surface. (For instance surface view of fault plane)

In deeper faults, surface view includes parts of the source which has been located within 10 km of surface.

Table 3-8 shows definitions of different seismic sources.

The seismic sources susceptible to intensive earthquakes with higher seismicity or sliding rates, have higher filed coefficients.

The field coefficient of the faults or seismic fields with the maximum magnitudes and lower sliding rates is 1.

According to the table 3-8, faults are classified into three A, B and C categories.

Most of active and important faults are classified within A or B categories.

This classification is based on faults' two important characteristics i.e. sliding rate and the expected maximum magnitude required for fault rupture.

Table 3-8 seismic source type

Seismic source characteristics		Seismic source definition	Seismic source type
Sliding rate (SR)(mm per year)	Maximum magnitude M		
$SR \geq 5$	$M \geq 7.0$	Faults which potentially can generate disasters with the maximum magnitudes and have higher rates of seismic activities	A
$SR < 5$ $SR > 2$ $SR < 2$	$M \geq 7.0$ $M < 7.0$ $M \geq 6.5$	All types expect A and C	B
$SR \leq 2$	$M < 6.5$	Faults which potentially cannot generate disasters with the maximum magnitudes and have lower rates of seismic activities	C



Chapter 4

Seismic Load Due to Geotechnical Threats





4-1-Geotechnical Threats

In seismic design of vital arteries, the effect of permanent ground displacement on components' performances should be taken into account. The main threats of earthquake resulting in permanent ground displacement are:

- liquefaction
- sliding
- faulting

4-2-Liquefaction

Liquefaction, which generally occurs in saturated soils with fine and non adhesive grains like sand, results in the following destructive effects on the structures of vital arteries:

- creation of uplift pressure and floating
- decrease of soil bearing capacity
- creation of ground horizontal displacements (lateral dispersion)
- creation of ground subsidence

Liquefaction-proof design should be carried out by evaluating ground permanent displacement due to liquefaction phenomenon, with respect to ground characteristics.

The regions requiring liquefaction-proof design should be defined and selected based on geological and geomorphologic conditions, ground condition and the position of the system or component which is under evaluation.

Permanent ground displacement due to liquefaction phenomenon is calculated in the following three states:

- Ground horizontal displacement due to lateral parallel dispersion of gable
- Ground horizontal displacement due to ground lateral dispersion (like seawalls of rivers and seas)
- Ground vertical subsidence

Since slopes and bulwarks could slide with and without liquefaction, more attentions should be paid to the design of vital arteries susceptible to this threat.

4-2-1- Identification of a Region Susceptible to Liquefaction

A region which is susceptible to liquefaction during earthquake should be identified by collecting available geological and geomorphologic data as well as evaluating that whether the surface layer of soil would be liquefied from micro-topography point of view and by referring to liquefaction possibility standard.

Regions with a lower possibility of liquefaction should be exempted from the regions require liquefaction evaluation.

The regions which require liquefaction evaluation are selected based on ground condition for installing and manufacturing vital arteries components.

- The effects of lateral dispersion due to liquefaction on the regions with slopes $\geq 1\%$ should be evaluated.
- The effects of lateral dispersion on the regions located within 100m of seawall and with 5m and more height should be evaluated.

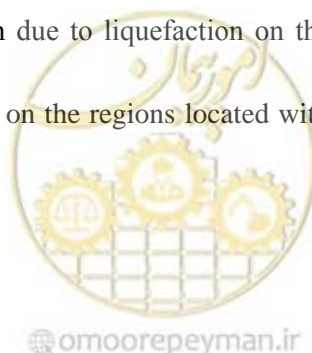

- The effects of subsidence due to liquefaction on the grounds in which vital arteries are constrained by huge structures like bridge columns should be evaluated.

The probability of liquefaction occurrence is estimated by four ways:

- General method which is based on geological and geomorphological data as well as experiences of past liquefactions
- Simplified method which is based on general geology map and test
- Accurate method which is based on liquefaction test results and seismic response analysis.
- Special methods which are based on shaking table test and in situ liquefaction test.

The above mentioned methods could be applied with respect to considered evaluations and the importance of considered equipments.

Methods A and B are frequently used.

We should pay more attention to the liquefaction probability during earthquake in the ground type 4.

The regions susceptible to liquefaction should be identified following evaluation of soil's surface layer (up to 20m depth) as well as measuring its liquefaction potential.

Soil's surface layer should be evaluated prior to measuring liquefaction potential.

In order to determine liquefaction resistance parameter, which is used in ground evaluation, we need geological information shown in table 4-1.

Table 4-1 geological information required for liquefaction evaluation using liquefaction resistance parameter

Geological information	
Structure of surface layer 'thickness of soil layer 'surface of underground water	Structure of surface layer
Value of N , γ_t specific weight ' mean diameter of grains (D_{50}) 'diameter of 1% of passed grains (D_{10}) ' fine grain count(FC) ' I_p plastic index ' percentage of clay (P_c)	Ground type

In sand alluvial layers which meet all the following three conditions, liquefaction evaluation should be carried out with respect to the measures of clause 4-2-2:

- Saturated soil layer in which the surface of underground water is higher than 10 m and the depth of the layer is at least 20 m below surface.
- Soil layers with $FC \leq 35\%$ or in the case of $FC > 35\%$ their plastic index (PI) is below 15.
- The soil layers include grains with mean diameters < 10 mm in which the diameter of the 10% of the passed grains (in grain curve) is below 1 mm.

In most layers which have been determined as liquefied layers the FC value is below 35%.

In some cases however liquefaction has been occurred in soil layers in which the value of FC was $> 35\%$ but this time they had lower plastic index like silty sand soil.

In the case of $FC < 0.35$ there is no need to carry out plastic and liquefaction limit test.

In the case of the lack of geological information about plastic index, a soil layer which its plastic index is below 15% could be considered as a soil layer which its clay percentage is below 15%.

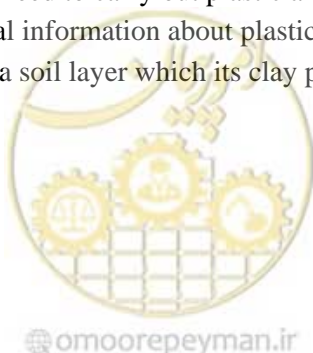

4-2-2- Liquefaction Evaluation

The liquefaction resistance parameter of the soils requiring liquefaction evaluation is calculated using relation (4-1). If the result is below 1, the soil layer should be considered as a soil susceptible to liquefaction.

Relations (4-1) to (4-8) show calculation steps:

$$F_L = R_r / L \quad (4-1)$$

$$R_r = c_w R_L \quad (4-2)$$

$$L = r_d K_H \sigma_v / \sigma'_v \quad (4-3)$$

$$r_d = 1.0 - 0.015z \quad (4-4)$$

$$\sigma_v = \gamma_{t1} h_w + \gamma_{t2} (z - h_w) \quad (4-5)$$

$$\sigma'_v = \gamma'_{t1} h_w + \gamma'_{t2} (z - h_w) \quad (4-6)$$

For near earthquakes we have:

$$c_w = \begin{cases} 1.0 & (R_L \leq 0.1) \\ 3.3R_L + 0.67 & (0.1 < R_L \leq 0.4) \\ 2.0 & (0.4 < R_L) \end{cases} \quad (4-7)$$

For other earthquakes we have:

$$c_w = 1.0 \quad (4-8)$$

In the above relations:

F_L : is liquefaction resistance parameter

R_r : is dynamic shear resistance ratio

L : is seismic shear stress ratio

c_w : is the adjusting parameter of ground movement during earthquake.

R_L : is frequent shear stress ratio (tri-axial)

r_d : is the increase of shear stress ratio versus depth

K_H : is horizontal seismic intensity at ground surface

σ_v : is total stress due to overburden pressure kN/m^2

σ'_v : is effective stress due to overburden pressure kN/m^2

Z : is the depth of selected location from ground surface m

γ_{t1} : is the special weight of soil kN/m^3

γ_{t2} : is the special saturated weight of soil kN/m^3

γ'_{t2} : is the effective special weight of soil

h_w : is distance between underground water surface and ground surface

Liquefaction occurs also in gravel soils in which the mean diameter of grains is more than 2 mm.

Grain diameters are determined through analyzing the diameter of sample grains in standard penetration test.

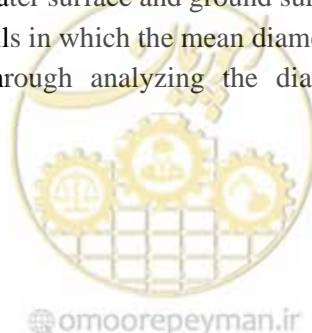

The samples which are used in the standard penetration test have lower diameters compared with in situ material which are obtained by grinding materials during test.

Although this difference essentially has no influence on the roughness of grains we can however assume that the mean diameter of 10 mm which is used in the standard penetration test almost equals to the in situ material with the mean diameter of 20 mm and more.

In the case that the diameter of the 10% of passed grains is less than 1 mm, gravel soil has higher levels of water penetration since it consists of fine grains with lower uniformity factor. For this, it is hardly liquefied.

Here, we should distinguish between grains' mean diameters. For example, in sand soil the value of D_{50} should be less than 2 mm while in gravel soil it should be more than 2 mm.

The frequent shear stress ratio is derived from relation (4-9):

$$R_L = \begin{cases} 0.0882\sqrt{N_a/1.7} & (N_a < 14) \\ 0.0882\sqrt{N_a/1.7} + 1.6 \times 10^{-6}(N_a - 14)^{4.5} & (14 \leq N_a) \end{cases} \quad (4-9)$$

For sand soil we have:

$$N_a = c_1 N_1 + c_2 \quad (4-10)$$

$$N_1 = 1.7N / (\sigma'_v / 98 + 0.7) \quad (4-11)$$

$$c_1 = \begin{cases} 1 & (0\% \leq FC < 10\%) \\ (FC + 40)/50 & (10\% \leq FC < 60\%) \\ FC/20 - 1 & (60\% \leq FC) \end{cases} \quad (4-12)$$

$$c_2 = \begin{cases} 0 & (0\% \leq FC < 10\%) \\ (FC - 10)/18 & (10\% \leq FC) \end{cases} \quad (4-13)$$

For gravel soil we have:

$$N_a = \{1 - 0.36 \log_{10}(D_{50}/2)\} N_1 \quad (4-14)$$

In above relations;

R_L : is frequent shear stress ratio

N : is the impact counts in the standard penetration test

N_a : modified N number in which the effect of grain size has been taken into account

N_1 : is the value of equivalent N with an effective overburden pressure of 89 KPa

c_1, c_2 : are correction factors of N in fine grain

FC: is fine grain count (percentage) (the percentage of fine grain crossing through a 75micrones screen).

D_{50} : is grains' mean diameter

4-2-2-2-Determination of Liquefaction Potential Index

A region which should be designed against liquefaction hazard should have the following conditions. Note that the value of F_L and the thickness of liquefied layer should be the maximum value of risk levels 1 and 2:

The LPI range (P_L) are determined as follows:

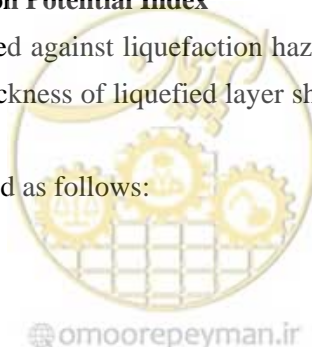

- $P_L < 5$ Low LP
- $5 < P_L \leq 20$ moderate LP
- $20 < LPI$ High LP

$$P_L = \int_0^{20} F_L W(z) dz \quad (4-15)$$

P_L : is LPI index (Liquefaction Potential Index)

F_L : is liquefaction resistance parameter; if $F_L \geq 1$ we have $F_L = 1$

$W(z)$: is the function of depth from ground surface $W(z) = 10 - 0.5z$

z : is depth from ground surface m

In the cases where a soil layer is considered as a perfect soft layer its geotechnical threats (shear modulus and resistance) should be considered zero in seismic design process.

In the seismic design of liquefied sand layer geotechnical parameter should be decreased proportional with liquefaction resistance parameter F_L , risk level and dynamic shear resistance ratio R_r . The parameters which should be decreased are horizontal reaction factor K_H and peak surface friction coefficient.

Geotechnical parameters of liquefied sand layer are defined as the product of geotechnical parameters with paying no attention to liquefaction and D_E coefficient (which is derived from table (4-2)). If $D_E = 0$ liquefaction parameters i.e. resistance and shear modulus, are considered zero in seismic design.

Table 4-2 decrease factor of geotechnical parameters DE

ranges F_L	Depth from ground surface z (m)	Dynamic shear resistance ratio R_r			
		$R_r > 0.3$		$R_r < 0.3$	
		Risk level 2	Risk level 1	Risk level 2	Risk level 1
$F_L \leq 1/3$	$0 \leq z < 10$	1/6	1/3	0	1/6
	$10 \leq z < 20$	1/3	2/3	1/3	2/3
$1/3 < F_L < 2/3$	$0 \leq z < 10$	2/3	1	1/3	2/3
	$10 \leq z < 20$	2/3	1	2/3	1
$2/3 < F_L < 1$	$0 \leq z < 10$	1	1	2/3	1
	$10 \leq z < 20$	1	1	1	1

In seismic design the weight of soil layer with zero or decreased geotechnical parameters, should be considered zero.

4-2-3-Ground Displacement Calculations

a) Ground horizontal displacement as a result of lateral dispersion due to liquefaction

Ground horizontal displacement as a result of lateral dispersion due to liquefaction in a steep surface is derived from relation (4-16):

$$\delta_h = 36c \left\{ \sum_{i=1}^n \frac{0.5\gamma_i H_i^2 + \sigma_{vi} H_i}{(0.5\gamma_i H_i^2 + \sigma_{vi})^{3/2} N_{bi}} \right\} \theta_g \quad (4-16)$$

$$N_{bi} = N_{li} + \Delta N_{li} \quad (4-17)$$

$$N_{li} = 1.7N_i / (\sigma'_{vi} / 98 + 0.7) \quad (4-18)$$



In which;

δ_h : is ground horizontal displacement

c : is site correction factor. In the regions located inside city it is 0.5 otherwise it is 0.1

H_i : is the depth of the i^{th} liquefied layer m

γ_i : is special weight of the i^{th} liquefied layer kN/m^3

N_{bi} : is modified N in which the effect of grain size on the i^{th} liquefied layer has been taken into account

N_{li} : is the value of equivalent N with an effective overburden pressure of 89 KPa in the i^{th} liquefied layer

ΔN_{li} : is modified N in which the effect of grain size on the i^{th} liquefied layer has been taken into account regarding the percentage of fine grain which is obtained from table (4-3)

N_i : is the value of N obtained from the standard penetration test carried out on the i^{th} liquefied layer

σ_{vi} : is total overburden pressure over the i^{th} liquefied layer kN/m^2

σ'_{vi} : is effective overburden pressure at the center of the i^{th} liquefied layer kN/m^2

θ_g : is the slope of gable (steep surface) to horizon

Table 4-3 the modified value of N in which the effect of grain size on the i^{th} liquefied layer has been taken into account with respect to fine grains percentage

FC	ΔN_{li}
$0\% \leq FC < 10\%$	0
$10\% \leq FC < 20\%$	5
$20\% \leq FC$	10

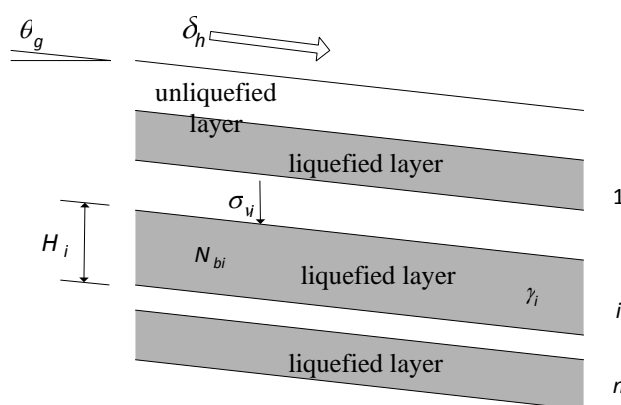

Fig. 4-1 lateral dispersion of steep ground

In calculating ground horizontal displacement the load factor of γ_8 is considered 1/8. In the case that the value of ground horizontal displacement obtaining by multiplying relation (4-16) and load factor is 3 m or more it is considered 3 m.



The area and distribution of ground horizontal displacement should be determined based on the area of liquefied layer as well as slope angle of ground surface. The area which experiences ground horizontal displacement should be considered elliptical as Fig. 4-2 and the maximum displacement occurs at its center which is distributed triangularly.

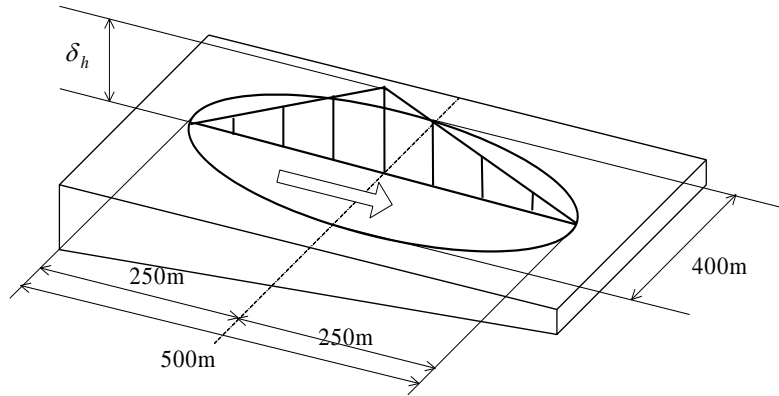

Fig. 4-2 distribution of ground horizontal displacement at steep ground

Ground horizontal displacement occurs in a limited area as a result of lateral dispersion effect due to liquefaction occurrence in a steep surface. Relation (4-19) has been derived from the results of the test of soil motion due to the acceleration of gravity and centrifugal forces as well as lateral dispersion damages of past earthquakes.

In the cases where soil layer itself includes several liquefied layers like Fig. 4-1, we assume that each liquefied layer flows like a viscose liquid in static condition and at the same time non liquefied layer moves under the liquefied layer. The velocity of motion at ground surface V_s is considered as the sum of velocities of all liquefied layers. Motion velocity is obtained from the relation (4-19).

$$V_s = \sum_{i=1}^n \frac{0.5\gamma_i H_i^2 + \sigma_{vi} H_i}{\mu_i} \cdot \theta_g \quad (4-19)$$

In which;

μ_i is the modulus of viscosity of the i^{th} liquefied layer which is proportional to total overburden pressure above the i^{th} layer and N is equivalent to the effective overburden pressure of the i^{th} liquefied layer.

Since the total overburden pressure at the center of the i^{th} liquefied layer is equal to $0.5\gamma_i H_i + \sigma_{vi}$, relation (4-20) is written as follows:

$$\mu_i \propto N_{i1} (0.5\gamma_i H_i + \sigma_{vi})^{1.5} \quad (4-20)$$

Since there is a relationship between horizontal displacement at ground surface and the velocity of ground surface, which is shown in relation (4-21), horizontal displacement of ground surface could be written as follows (this relation is a generalized case of the relation (4-16)).

$$\delta_h = \alpha \times c \left\{ \sum_{i=1}^n \frac{0.5\gamma_i H_i^2 + \sigma_{vi} H_i}{(0.5\gamma_i H_i + \sigma_{vi})^{3/2} N_{bi}} \right\} \theta_g \quad (4-21)$$

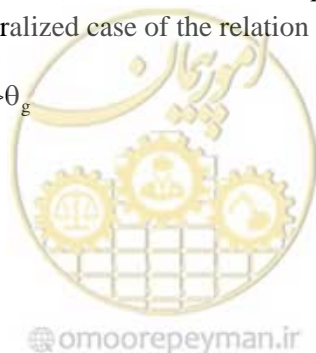

In which α is a coefficient which is considered as $((\text{kN}/\text{m}^2)^{1/2}\%)$ based on the lateral dispersions experienced in past earthquakes.

b) Ground horizontal displacement due to lateral dispersion of beach grounds (beaches of sea and rivers)

Ground horizontal displacement due to lateral dispersion of beach regions should be calculated in accordance with the following steps:

- Calculating seawall displacement
- Calculating the lateral dispersed region behind seawall
- Calculating ground horizontal displacement in the location of installations.



Fig. 4-3 a typical example of ground horizontal displacement as a result of lateral dispersion due to the occurrence of liquefaction behind seawall

Ground displacement in seawall area should be calculated with respect to structure type and liquefaction condition in behind ground and its foundation.

$$\Delta_w = F_w H_w / 100 \quad (4-22)$$

In which;

Δ_w : is wall displacement (m)

F_w : is deformation percentage (%) (It is derived from table 4-4)

H_w : is wall height (m)

Table 4-4 deformation percentage of seawall

Deformation percentage (%)	Liquefaction status		Seawall type
15	Ground behind seawall has been liquefied		Weight seawall
30	Ground behind seawall as well as foundation have been liquefied		
20	Ground around foundation has not been liquefied	Ground behind seawall has been liquefied	Sheet pile (steel shield) seawall
40	Ground around foundation has been liquefied		
75	Ground behind seawall, ground around installations and foundation have been liquefied		

The length of the area which is susceptible to the liquefaction threat should be calculated using the N values of layers susceptible to liquefaction and wall displacement.

$$L_{w0} = 250\Delta_w / N_1 \quad (4-23)$$

In which;

L_{w0} : is the length of lateral dispersed region (m)

Δ_w : is wall displacement (m)

N_1 : is equivalent N with an effective overburden pressure of 98kN/m^2

$$N_1 = 1.7N / (\sigma'_v / 98 + 0.7) \quad (4-24)$$

Where;

N : is the value of N obtained from the standard penetration test

σ'_v : is effective overburden pressure kN/m^2

Ground horizontal displacement at the location of installations should be derived from relation (4-25):

$$\delta_h = \Delta_w \exp(-3.35L_{wp} / L_{w0}) \quad (4-25)$$

Where;

δ_h : is ground horizontal displacement due to lateral dispersion at the location of installations

Δ_w : is wall displacement (m)

L_{wp} : is distance between wall and installation (m)

L_{w0} : is the length of lateral dispersed area

Basically, the load factor of γ_δ is considered 1/3.

The relation (4-16) which gives lateral dispersion due to ground horizontal displacement has been derived from the experiences of past earthquakes.

a) Vertical Subsidence

- Vertical subsidence should be considered 5% of the thickness of liquefied layer

- In computing vertical subsidence the load factor of γ_δ is basically considered 1. The experimental results of subsidence due to liquefaction imply a relationship between liquefaction resistance parameter F_L , relative density D_r and volumetric strain ϵ_v .

- Ground subsidence is obtained by multiplying the thickness of liquefied layer and volumetric strain, which is derived from relative density and liquefaction resistance parameters.

- Generally, the relative density of soil layer is 40% and more. Even if the liquefaction resistance parameter is a small value, the volumetric strain is considered 50% for meeting safety factor requirements.

4-2-4- Calculation of Lateral Pressure Due to Lateral Dispersion

When the effects of lateral dispersion are taken into account, the lateral pressure generating due to lateral dispersion should be derived as follows. The lateral pressures obtaining from relations (4-26) and (4-27) should be respectively applied on structural components of non-liquefied and liquefied layers at the top of the depth which has been considered for the effects of lateral dispersion.

$$q_{NL} = c_s c_{NL} K_p \gamma_{NL} z \quad 0 \leq z \leq H_{NL} \quad (4-26)$$

$$q_L = c_s c_L [\gamma_{NL} H_{NL} + \gamma_L (z - H_{NL})] \quad H_{NL} < z \leq H_{NL} + H_L \quad (4-27)$$

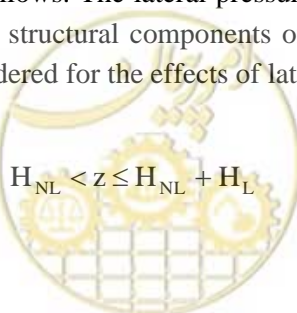

Where;

q_{NL} : is lateral pressure due to lateral dispersion kN/m^2 , applying on structural components located on non-liquefied layer at the depth of z (m)

q_L : is lateral pressure due to lateral dispersion kN/m^2 , applying on structural components located on liquefied layer at the depth of z (m)

C_S : is correction factor of distance from water. This factor is derived from table 4-6

C_{NL} : is the correction factor of lateral pressure in non-liquefied layer. This factor is derived from table 4-5 in accordance with liquefaction potential index (LPI) which is derived from the relation (4-15)

C_L : is the correction factor of lateral pressure in liquefied layer. (It is considered 0.3)

k_p : is passive earth pressure coefficient (in normal condition)

γ_{NL} : is mean special weight of non-liquefied layer kN/m^3

γ_L : is mean special weight of liquefied layer kN/m^3

z : is depth from ground surface

H_{NL} : is the thickness of non-liquefied layer m

H_L : is the thickness of liquefied layer m

Table 4-5 correction factor of lateral pressure due to lateral dispersion in non liquefied layer

Correction factor C_{NL}	LPI index (m^2)
0	$LPI < 5$
$(0.2LPI - 1) / 3$	$5 < LPI \leq 20$
1	$20 < LPI$

Table 4-6 correction factor of distance from water

Correction factor	Distance from water (m)
1.0	$S \leq 50$
0.5	$50 < s \leq 100$
0	$100 < S$

4-3- Ground Sliding

4-3-1 evaluation of sliding due to permanent ground displacement

Ground sliding (sliding) due to permanent ground displacement should be evaluated through the following steps:

- evaluation of the sliding potential of soil
- evaluation of the sliding and gable deformation potential

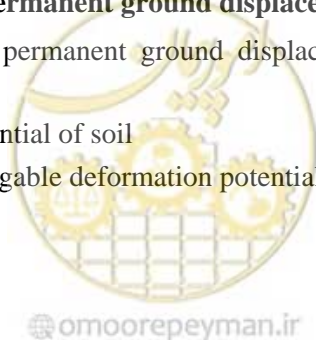

- evaluation of sliding probability and gable deformation
- evaluation of sliding threats and gable deformation

4-3-2- Calculations of sliding due to permanent ground deformation

In order to evaluate gable displacement due to earthquake, first of all the safety factor of gable's static stability (FS) should be determined. We should take into account in our investigations the parameters which are related to gable situation like slope, shear strength of soil or rock, the condition of underground water, layering, sealing, cleavage and crack and any other effective parameter.

Critical acceleration at which gable starts to displace is determined through relation (4-28):

$$a_c = g(FS - 1) \sin \alpha \quad (4-28)$$

In which α is slope angle (degree)

The generated sliding due to permanent ground displacement (PGD) is estimated using relation (4-29):

$$\log_{10}(PGD_s) = 1.546 + 1.460 \log_{10}(I_A) - 6.642 a_c \quad (4-29)$$

Where;

The unit of PGD_s is centimeter and I_A is Ariyas intensity (m/s) which is estimated from relation (4-30):

$$I_A = -4.1 + M - 2 \log_{10}(R) \quad (4-30)$$

Where M is earthquake magnitude and R is distance from earthquake center (KM) which is determined through statistical threat analysis.

We should note that permanent ground displacement is calculated for risk level 2 using M and R parameters. If we have no access to the data of earthquake magnitude with a 475 years return period, we can define mean annual increase of earthquake magnitude using Gutenberg-Richter law.

$$\log \lambda_m = a_1 - b_1 M \quad (4-31)$$

In which;

λ_m : is mean annual increase of M magnitude

a_1 : is mean count of annual earthquakes with a magnitude of zero or more

b_1 : is relative likelihood of (probability) earthquake with low and high magnitudes

In order to prepare an instruction for calculating annual mean rate we need complete seismic database. If we could obtain the value of magnitude M , appropriate attenuation relationship could help us to determine the focal distance of earthquake with maximum earth acceleration and maximum magnitude.

Numerical simulation is another method for calculating gable displacement.

4-4- Fault Displacement

In the cases where a pipeline crosses through an active fault it should be designed so that it could withstand against fault displacement. Also, if the fault displacement is apparent on ground surface, installations should be designed so that they could withstand against its effects.

A fault which has been displaced during past 10,000 years is defined as an active fault. All intersection points of an active fault through network should be taken into account regardless that the fault has been evaluated against ground shakes or not. Any fault which has not been recognized as an inactive fault

should be considered an active fault unless we could prove that it is not susceptible to earthquakes with a magnitude of 6.25 Richter and with a return period of 1000 years or less.

4-4-1- Evaluation of Active Fault

The existence of an active fault should be confirmed through special geological studies related to recognizing active faults.

A region through which an active fault may pass should be confirmed through geological inspections, geophysical discoveries, drilling excavations and inspecting trenches.

4-4-2- Fault Displacement for Seismic Design

The amount of surface displacement due to surface fault rupture is derived from relation (4-32) or other valid models:

$$\log_{10}(\text{MD}) = a + bM \quad (4-32)$$

Where;

MD : is peak fault displacement at ground surface (PGD) (m)

M : is earthquake magnitude based on design return period

a, b : are fault model coefficients which are derived from table (4-7)

Table 4-7 Fault model coefficients

coefficients		Fault model
b	a	
1.03	-7.03	Strike-slip
0.29	-1.84	compressive
0.89	-5.9	normal
0.82	-5.46	all

4-4-3- Peak Strain at Fault Intersection

Pipe strain due to PGD (m) at the intersection point with fault is calculated as relation (4-33):

$$\varepsilon_{\text{pipe}} = 2 \left[\frac{\text{PGD}}{2L_a} \cos \beta + \frac{1}{2} \left(\frac{\text{PGD}}{2L_a} \sin \beta \right)^2 \right] \quad (4-33)$$

Where β and L_a are respectively the angle of intersection point to pipe axis (degree) and effective length of pipe deformation due to fault displacement.



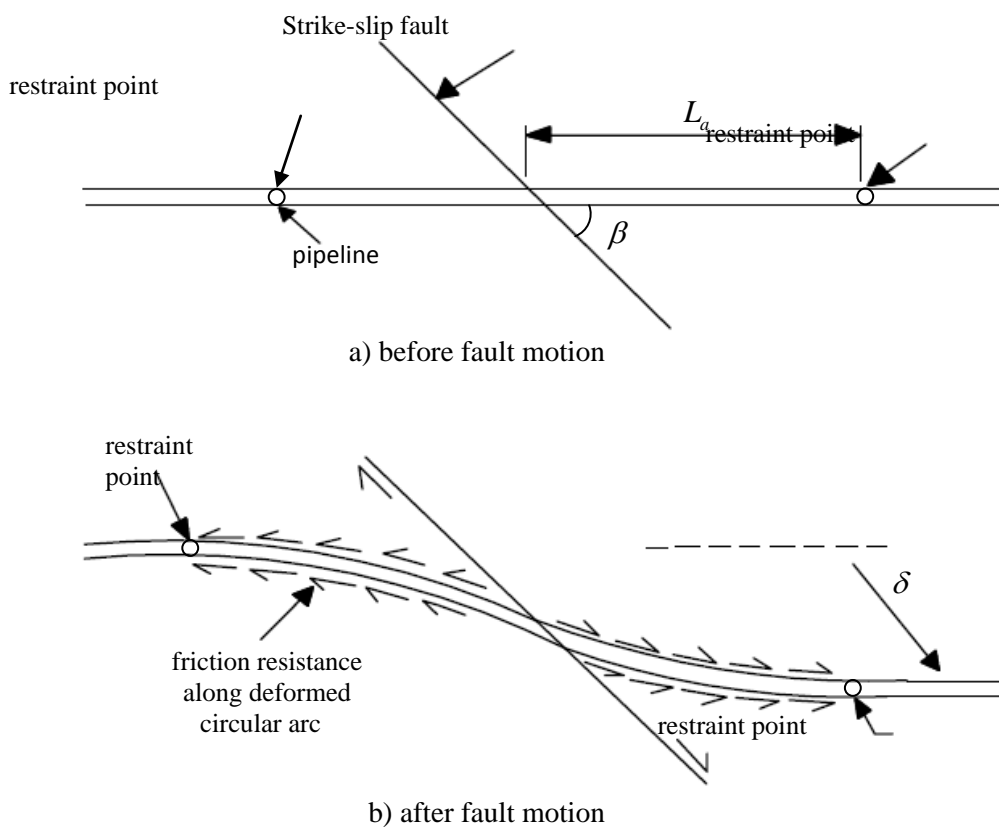

Fig. 4-4 pipe model at intersection point with fault





Appendix 1

Computing Periods of Installations





1-Introduction

Regarding the fact that natural vibration period of structures plays important role in the determination of seismic loads applying on them; this index presents relations for calculating the stiffness and vibration period of some important components of vital arteries. For similar cases one can use relations presented in the standard 2800 or other valid codes.

2-Natural Vibration Period of Spherical Tanks

$$T = 2\pi \sqrt{\frac{W_0}{Kg}} \quad (1)$$

Where;

T : is natural period S

g : is the acceleration of gravity mm/s^2

W_0 : is operating weight N which equals to the sum of tank weight and fluid effective weight

Effective weight of fluid is derived by multiplying fluid weight and effective weight ratio shown in Fig. 1

K : is horizontal rigidity N/mm

$$K = \frac{1}{\frac{1}{K_1} + \frac{1}{K_2}} \quad (2)$$

In which : K_1 is rotational rigidity of whole body N/mm

$$K_1 = \frac{3n_s EA_{CL} D_B^2}{8H_C^2} \quad (3)$$

And : K_2 is shear rigidity of whole body N/mm :

$$K_2 = nK_C \left(\frac{2C}{C_2 + \frac{4LK_C}{EA}} + 1 \right) \quad (4)$$

Where;

$$K_C = \frac{3EI_C}{H_1^3} \quad (5)$$

$$A = \frac{1}{\frac{C_3}{A_B \cos^3 \theta_e} + \frac{C_4 \tan^3 \theta_e}{A_{CL}}} \quad (6)$$

$$C_1 = \frac{1}{4} \lambda_C^2 (3 - \lambda_C^2)^2 \quad (7)$$

$$C_2 = \lambda_C^2 (1 - \lambda_C)^3 (3 + \lambda_C) \quad (8)$$



In which;

H_C : is the height from bottom surface of base plate to the centre of spherical body mm

n_s : is number of supports

E : is the modulus of longitudinal elasticity of bottom support materials N/mm^2

A_{CL} : is the cross section of bottom support mm^2

D_B : is the diameter of the circle drawn using support centers

L : is distance between two adjacent supports mm

H_1 : is effective height derived from relation (9):

$$H_1 = H_C - L_w \quad (9)$$

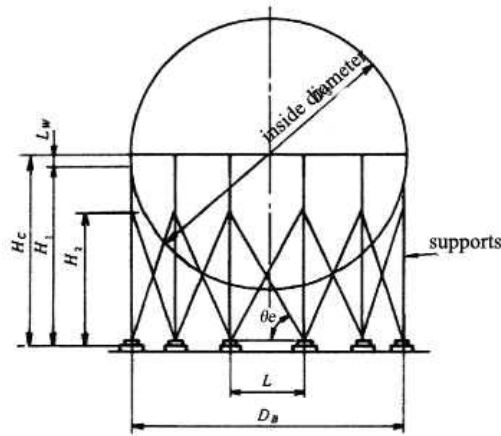

Fig. 1 spherical tank

$$L_w = \frac{1}{2} \sqrt{\frac{D_C D_S}{2}} \quad (10)$$

Where;

D_C : is outside diameter of upper support mm

D_S : is inside diameter of spherical tank mm

I_C : is the moment of inertia of bottom support surface mm^4

A_B : is brace cross section mm^2

θ_e : is angle between diagonal brace and horizontal (degree)

C_3, C_4 : are values presented in table 1



Table 1 brace coefficients

Pipe restraint	Joined beam restraint	
0.5	1.0	C_3
0.0	1.0	C_4

3-Natural Vibration Period of Cylindrical Tanks

$$T = \frac{2}{\lambda} \sqrt{\frac{W_0}{\pi g E t_{1/3}}} \quad (11)$$

In which T is the natural vibration period s

$$\lambda = 0.067 \left(\frac{H_L}{D_0} \right)^2 - 0.30 \left(\frac{H_L}{D_0} \right) + 0.46 \quad (12)$$

Where;

D_0 : is inside diameter m

H_L : is the height related to the peak surface of fluid mm

g : is the acceleration of gravity mm/s^2

E : is the modulus of longitudinal elasticity of adjacent panel N/mm^2

$t_{1/3}$: is the thickness of adjacent panel at the 1/3 of the height of adjacent panel

W_0 : is operating weight N

It equals to the sum of the following weights:

- Weight of inside adjacent panel
- Half of the weight of cold insulator. (in the cases where the insulator has been separated from the adjacent panel its weight is eliminated)
- Weight of inside roofing (in simple shells it equals to roofing weight)
- Weight of cold insulator at roofing
- Total weight of fluid

4-Natural Vibration Period of the Framed Structures of Towers and Vessels

It is calculated based on the ratio of framed structure weight:

The ratio of framed structure weight = operating weights of tower and tank/total weight



4-1- the peak value of framed structure weight ratio is 0.1 and less

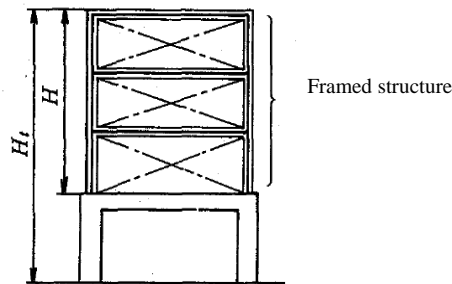

Fig. 2 H_{sf} and H_t

$$T = 0.01H + 0.02H_t \quad (13)$$

Where;

T : is natural vibration period

H : is the height of the steel part of framed structure m

H_t : is the height of the framed structure m

4-1- the peak value of framed structure weight ratio is more than 0.1

$$T_{fs} = 0.057\sqrt{\eta} \quad (14)$$

In which : η is the peak displacement of the framed structure mm , when the weight of framed structure has been distributed horizontally. In this condition tower or tank are considered rigid structures.



Appendix 2

General Trend of Loading and Seismic Analysis of This Instruction





The following steps are the general trend of loading and seismic analysis of vital arteries followed in this instruction:

- a) Determining that whether the risk level is 1 or 2
- b) Determination of ground velocity and acceleration corresponding with both risk levels
- c) Determination of structure's condition in terms of the influence of earthquake force (force of inertia) and ground displacement
- d) Determination of installation's importance factor with respect to the related system
- e) Determination of structure's behavior during earthquake and the complexity level of behavior (based on engineers' experiences and their opinion and making comparisons with the measures of this instructions for making decision that whether spectrum or dynamic methods should be selected for more important and more complex installation)
- f) Conducting initial design, analysis and extraction of components' internal forces and critical sections' stresses for both risk levels 1 and 2.
- g) Selecting ductility method (based on ultimate limit idea) as well as controlling the critical stresses and strains generated due to earthquake level 2 with allowable values (don't conflict with allowable stress values) in ductility design method
- h) Controlling the design carried out in previous step via allowable stress method (based on operational or damage limit idea) for the effects of the earthquake level. This step is done in order to make sure that no component will be physically damaged i.e. the material will not reach to their yield point. (continuous operation)
- i) In the cases where both ultimate and damage limits are not sufficient for designing, by applying some physical and geometrical changes the design process will be repeated until a required satisfaction level be obtained.

For simplification purposes the above steps are presented in a flowchart as follows:



